

Eaton - A new era of electronic miniature circuit breakers

PXS24

Maximum reliability for 24 VDC circuits



EATON

Powering Business Worldwide

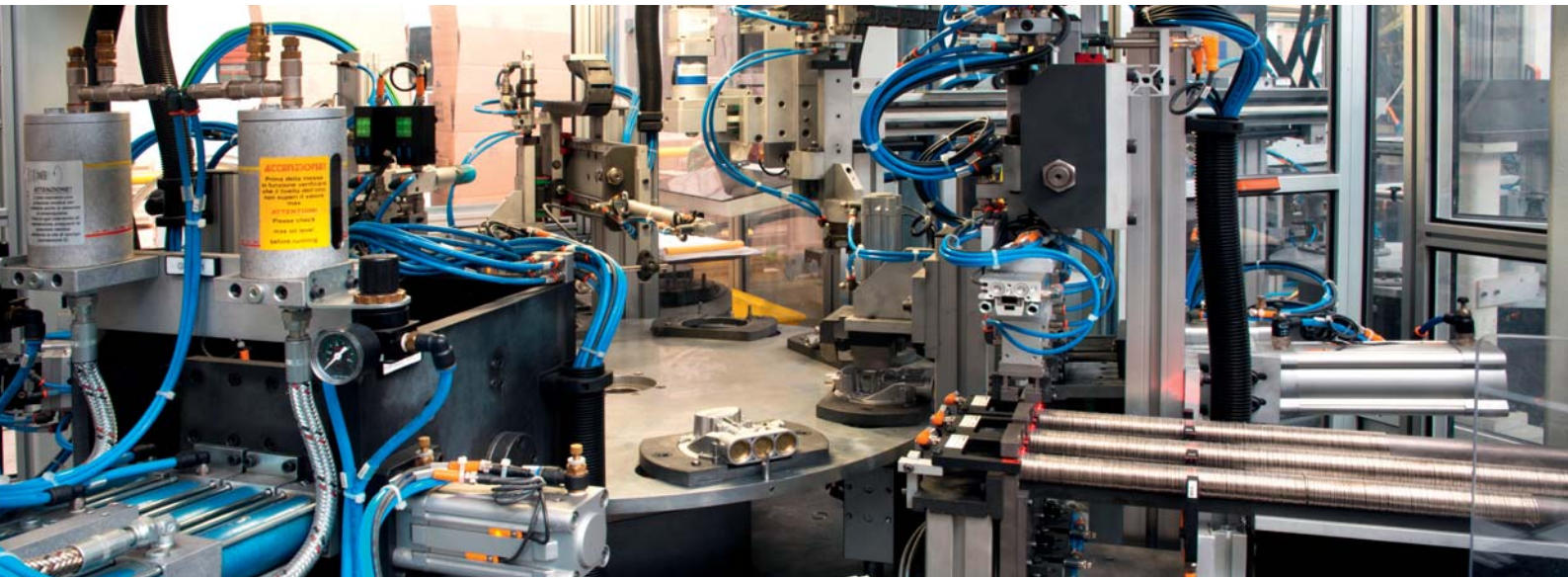

Maximum safety

With electronic overload protection

The rise of electronic current monitoring is unstoppable. Eaton is at the forefront of developing electronic solutions that offer maximum protection as well as a multitude of practical advantages.

While electromechanical solutions provided sufficient protection in applications with traditional power supplies, this is no longer the case for electronic power supplies. They are short-circuit-proof, but in the event of a fault they reduce the output voltage to such low levels that the remaining energy is too weak to trigger conventional circuit breakers.

Electronic solutions thus provide much greater safety: They are able to detect overloads quickly and then switch off only the faulty machine parts from the power supply. The machine remains controllable and can be shut down in a controlled way, for example.

The PXS24 not only ensures the highest possible system availability, but it also saves time, space and installation costs.

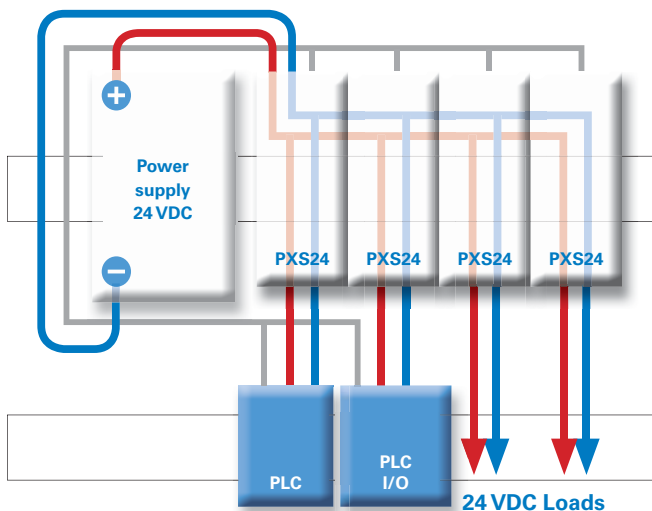

PXS24 highlights:

- Modular system
- Direct connection of up to 3 loads
- Channel-specific controlling, switching and signalling
- Subsequent control - simple linking of channels
- Simple and quick installation with push-in terminals and busbars

A modular and scalable system

Saving space and costs



With the PXS24, you save costs and need less space for your installation. There is no need to buy four or even eight channel modules. You can also easily expand the number of channels later. This will pay off, for example, if a channel is missing during the installation, or if additional channels are needed at a later point.

Should you wish to reserve capacity for later upgrades and pre-install the busbar system ahead of time, you have the option to choose blank modules that can later be replaced quickly with electronic ones.

Everything under control & integration into the control system

Individual and group-fault messages



In practice, sum-fault indication are often not enough. The professional monitoring and visualization of systems requires the ability to process individual status signals for each channel.

These outputs can be connected to a PLC as individual or group indication, as desired.

The PXS24 is also equipped with a remote reset function. In addition, the digital inputs allow functional switching of loads, which can reduce the number of coupling relays.

Prevent negative impacts

By consecutively shutting down other machine parts in the event of a fault.



If a fault occurs in one part of a system, the impact should be minimized by shutting down relevant other, non-affected parts. Take the example of a cement mixer: If the main motor fails, the conveyor belt should immediately be stopped to avoid clogging – and thus a complicated manual cleaning of the plant.

The PXS24 recognizes this problem and controls the required processing via its fault output. If desired, the fault output of the PXS24 can also be directly linked to another PXS24, without the need for additional configuration in the PLC. The PXS24 will then switch off the “secondary” PXS24 within a few milliseconds.

Includes potential-distribution terminals

Up to 3 loads per channel

6 load terminals
3x +24 VDC protected
3x GND



It is rare that a circuit breaker is connected to only one load; usually, 2 or 3 loads are connected. Until now, this required that the output of the circuit breaker be always connected to a separate terminal block. This set-up is error-prone and unduly cumbersome. The PXS24 has three integrated +24 VDC and GND-terminals each. This eliminates the need for complicated, fault-prone wiring.

Both supply cables start at the same device: the PXS24. This not only removes the need for (often very large) loops, but also increases electromagnetic compatibility (EMC).

Practical to use

Thanks to its intelligent set-up, the PXS24 saves time and reduces sources of error:

Reliable protection

Capacitive loads are often a challenge for electronic circuit breakers but not for the PXS24. It ensures controlled, reliable and protected supply up to 20,000µF. For drives, there is practically no (inductive) limit.

Robust design

The design of the PXS24 pays homage to the robust and well experienced design of electromechanical circuit breakers. This ensures easy handling and the robustness required in industrial applications.

Push-in terminals

All cable connections are implemented as push-in terminals. The terminal capacity is 2.5 mm² for flexible wires with end sleeves, or up to 4 mm² for solid wires. The only time you will need a screw driver is to open the lock when removing the connections.

The push-in technology ensures that the terminals are safe, even when exposed to the vibrations that commonly occur in industrial applications.

The busbar system

At its back, each PXS24 has a busbar element that shares its supply side with other devices. Busbars are available in different sizes (up to 1 m) and can be cut to any desired length. They are simply pushed into the connectors, without the need for any tools.

To reduce costs further, you can order all PXS24 models either with or without integrated feed-in terminals. To combine 10 PXS24 units, for example, only one unit with input terminals is required, as the supply of the other modules is done via the busbars.

The in- and outputs are PLC-compatible

Both the control inputs as well as the control outputs conform to IEC-EN 61131-2. This ensures:

- that the communication with the PLC runs smoothly
- that the input is robust enough to respond to a sensors
- that the input can control functions that previously required a separate PLC-output.

The PXS24 makes it possible, among other things, to switch directly to another PXS24 in the case of a fault.

The local sliding switch

The local sliding switch turns the PXS24 on and off and also resets the device.

For safety reasons an “off” will always takes precedence. So only when the local sliding switch is in the “on” position and there is no “off” from the PLC, the PXS24 will be active.

Global use

All versions of the PXS24 have UL approval. This means that there are no difficulties with installing the PXS24 in machines for use in North America.

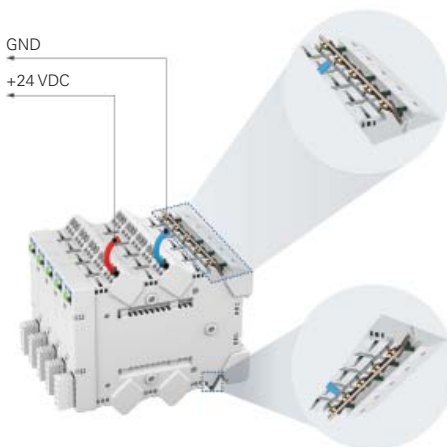

5 modules in side view:
1 channels is supplied via the internal feed in terminals, the other channels are supplied via the busbars.



2x control output
2x control input
1x GND



Installation concept

The PXS24 installation concept allows that up to 3 loads will be directly connected to the output side. This helps to reduce the number of potential-distributor terminals, which helps to reduce the size of the control cabinet.

Example of conventional installation

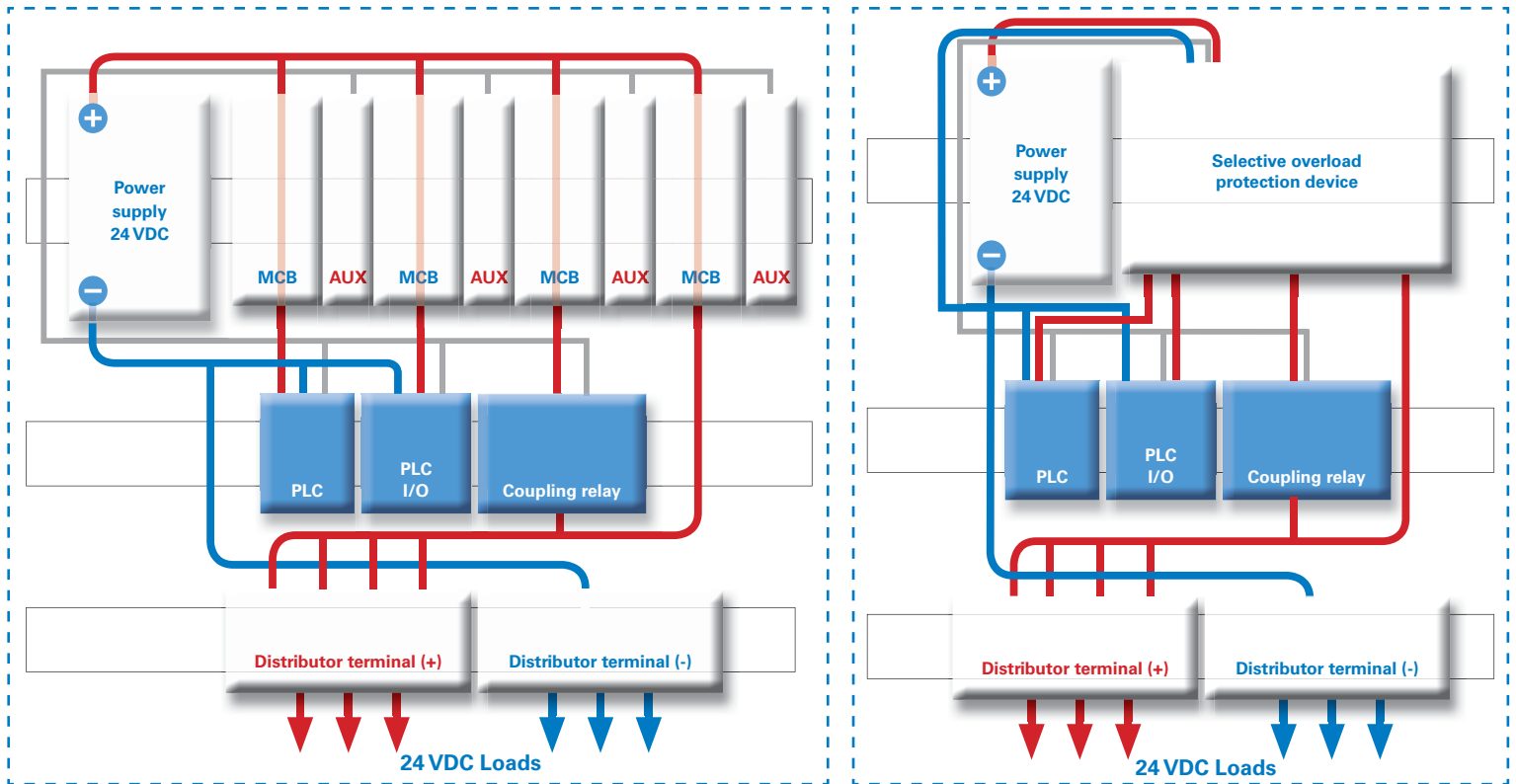

Example of PXS24 installation

In addition, features such as the push-in terminals or the busbar help to reduce installation times. Coupling relays can be reduced because operational switching will be also done by PXS24. Eaton's new PXS24 concept not only allows you to reduce installation cost and effort, but also saves space in the switch cabinet.



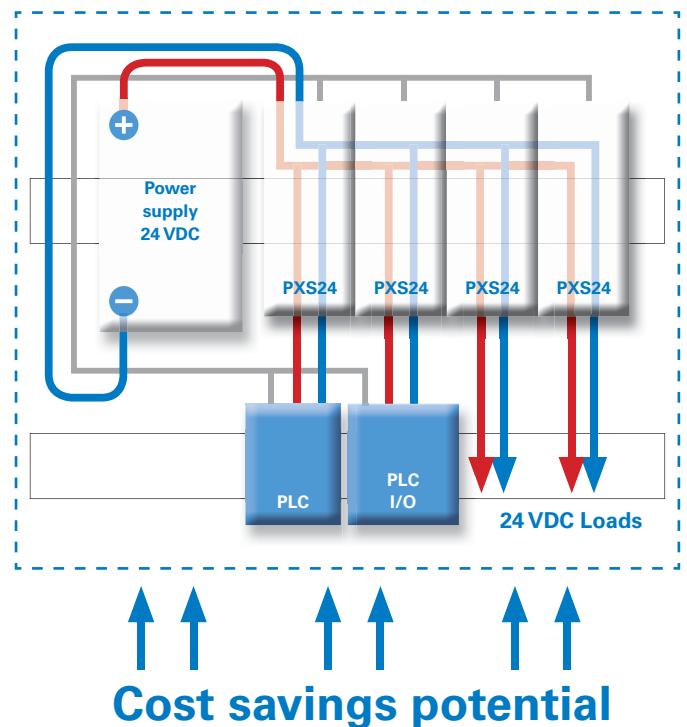
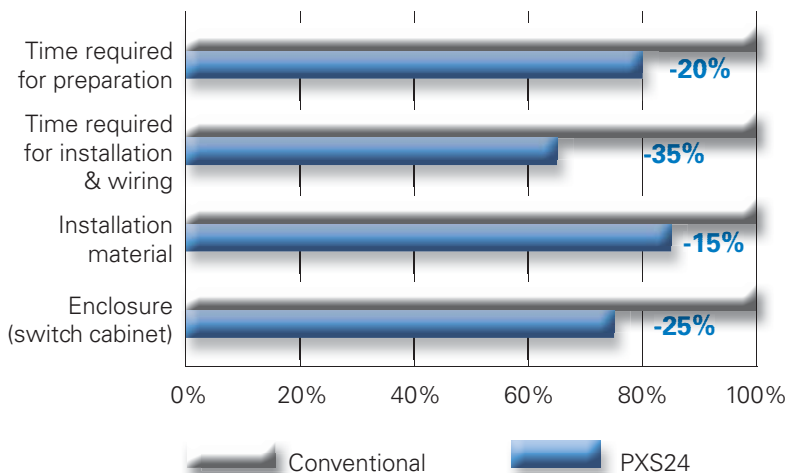

The cost savings potential offered by Eaton's PXS24:



Protective Devices

Electronic Protective Devices

PXS24 - Selection Information

	Rated current I_n (A)	Rated voltage U_n (V)	Article No.	Type Designation
PXS24...F/ORT-IT				
Standard with feed-in terminals (with Communication plug)				
	2	24	PXS24S02A001	PXS24S-e2/F/ORT-IT
	4	24	PXS24S04A001	PXS24S-e4/F/ORT-IT
	6	24	PXS24S06A001	PXS24S-e6/F/ORT-IT
	8	24	PXS24S08A001	PXS24S-e8/F/ORT-IT
	10	24	PXS24S10A001	PXS24S-e10/F/ORT-IT
	13	24	PXS24S13A001	PXS24S-e13/F/ORT-IT
	16	24	PXS24S16A001	PXS24S-e16/F/ORT-IT
PXS24...F/ORT				
Standard without feed-in terminals (with Communication plug)				
	2	24	PXS24S02A002	PXS24S-e2/F/ORT
	4	24	PXS24S04A002	PXS24S-e4/F/ORT
	6	24	PXS24S06A002	PXS24S-e6/F/ORT
	8	24	PXS24S08A002	PXS24S-e8/F/ORT
	10	24	PXS24S10A002	PXS24S-e10/F/ORT
	13	24	PXS24S13A002	PXS24S-e13/F/ORT
	16	24	PXS24S16A002	PXS24S-e16/F/ORT
PXS24E...F-IT				
Economy with feed-in terminals (without Communication plug)				
	2	24	PXS24E02A001	PXS24E-e2/F-IT
	4	24	PXS24E04A001	PXS24E-e4/F-IT
	6	24	PXS24E06A001	PXS24E-e6/F-IT
	8	24	PXS24E08A001	PXS24E-e8/F-IT
	10	24	PXS24E10A001	PXS24E-e10/F-IT
PXS24E...F				
Economy without feed-in terminals (without Communication plug)				
	2	24	PXS24E02A002	PXS24E-e2/F
	4	24	PXS24E04A002	PXS24E-e4/F
	6	24	PXS24E06A002	PXS24E-e6/F
	8	24	PXS24E08A002	PXS24E-e8/F
	10	24	PXS24E10A002	PXS24E-e10/F

PXS24 - Accessories

	Length	Article No.	Type Designation
Busbar max. 30V			
Can be cut Max. current: 80 A (at 55°C ambient temperature)	1 m	PXS24BB00001	PXS24-BB/80A/1m
	4 MU (appr. 70 mm)	PXS24BB00004	PXS24-BB/80A/4TE
	8 MU (appr. 140 mm)	PXS24BB00008	PXS24-BB/80A/8TE
	12 MU (appr. 210 mm)	PXS24BB00012	PXS24-BB/80A/12TE
Busbar cover			
Can be cut	1 m	PXS24ACC0002	PXS24-BBC
Placeholder			
Module with no electrical function		PXS24ACC0000	PXS24-PCH
Input terminals			
	2 pcs. per power supply are needed! Terminal capacity 1.5 - 16 mm ² with or without end-sleeves, rigid and flexible Max. load current: 60 A (at 50°C ambient temperature, only in connection with PXS24-BB...)	PXS24ACC0001	PXS24-IT

Protective Devices

Electronic Protective Devices

PXS24 - Technical Data

Mark	CE	Communication plug	2x control output (internal linked) 2x control input (internal linked) 1x GND
Certification	UL508 + UL2367 (Section 10 and 12)	Busbar	LINE (+) and GND (-); max. 50 A in various length up to 1 m
Product Standard	Applicable sections of EN 60947-1, EN60947-5-1, EN61009-1, EN61131-2, EN61000-4-2 Details see In-House Standard WN-PXS24	Montage	Snapping on DIN rail TH35 (EN 60715)
Electrical specifications		Status LED	bi-colour; Green = OK; Red = tripped; OFF = channel not in use
Operating voltage U_B	24 DC (16...30V DC)	Sliding switch	ON/OFF/Reset
Rated current I_N	Fixed; 2, 4, 6, 8, 10, 13, 16 A	Control output	Tripped; about Communication plug (according to IEC 61131-2), Class: 0.1 A; Type1/Type2 and Type3 Digital Inputs Max. 30 PXS24V Other indication devices up to 0,2 A @ 24 V (EATON RMQ series,...)
Overload and Short circuit current Protection	Typ. $1.3 \times I_N$ with active current-limiting to $1.2 \times I_N$	Control input	ON/OFF/Reset; about Communication plug (according to IEC 61131-2) Type1/Type3; Max. 30 PXS24V
Trip characteristic	see time / current table	Sequencer	about Communication plug
Capacitive Loads	up to 20,000 μ F	Text field	17.5 x 6 mm
Inductive Loads	$I_N \leq 6A \dots \tau_{max} \leq 60ms$ $6A < I_N \leq 10A \dots \tau_{max} \leq 12ms$ $10A < I_N \leq 16A \dots \tau_{max} \leq 7.5ms$	Degree of protection	IP 20
Mechanical specifications		Operation temperature	-30°C to 55°C
Number of Channels	1	Storage Temperature	-40°C to 100°C
Width	17.5 (1TE)		
Height	92.5 mm		
Depth	119.2 mm		
Type of terminals	Push-In terminals		
Line terminals (optional)	3x LINE (+) and 3x GND (-)		
Load terminals	3x LOAD (+) and 3x GND (-)		
Terminal capacity	2.5 mm ²		
Input/Output terminals	(flexible with wire end sleeve) 4 mm ² (rigid)		
Terminal capacity	1 mm ²		
Communication plug	(flexible with wire end sleeve) 1.5 mm ² (rigid)		

Time / Current Table

Rated current I_N	Classification	Active current limiting
2 A	460 ms	$1,2 \times I_N$
4 A	240 ms	$1,2 \times I_N$
6 A	160 ms	$1,2 \times I_N$
8 A	108 ms	$1,2 \times I_N$
10 A	108 ms	$1,2 \times I_N$
13A	75 ms	$1,2 \times I_N$
16 A	75 ms	$1,2 \times I_N$

Overview of the PXS24 features

Feature	Economy	Standard
Rated current (fixed, 2, 4, 6, 8, 10, 13, 16 A)	0-10 A	0-16 A
Active current limiting	x	x
Modular system	x	x
3 load connections (+/-)	x	x
Push-in terminals	x	x
Busbar (+/-)	x	x
Local status LED	x	x
Local switch (on/off/reset)	x	x
Sequencer		x
Digital control outputs (on/off/reset)		x
Digital control inputs (on/off/reset)		x

Eaton is a power management company with 2017 sales of \$20.4 billion. We provide energy-efficient solutions that help our customers effectively manage electrical, hydraulic and mechanical power more efficiently, safely and sustainably. Eaton is dedicated to improving the quality of life and the environment through the use of power management technologies and services. Eaton has approximately 96,000 employees and sells products to customers in more than 175 countries.

For more information, visit Eaton.com.



Eaton Industries (Austria) GmbH
Scheydgasse 42
1210 Vienna
Austria

Eaton
EMEA Headquarters
Route de la Longeraie 7
1110 Morges, Switzerland
Eaton.eu

© 2018 Eaton
All Rights Reserved
Printed in Austria
Publication No. BR019007EN
Article number 193156-MK
February 2018
Graphics: SRA, Schrems

Changes to the products, to the information contained in this document, and to prices are reserved; so are errors and omissions. Only order confirmations and technical documentation by Eaton is binding. Photos and pictures also do not warrant a specific layout or functionality. Their use in whatever form is subject to prior approval by Eaton. The same applies to Trademarks (especially Eaton, Moeller, and Cutler-Hammer). The Terms and Conditions of Eaton apply, as referenced on Eaton Internet pages and Eaton order confirmations.

Eaton is a registered trademark.

All other trademarks are property of their respective owners.

Follow us on social media to get the latest product and support information.

