

Rittal – The System.

Faster – better – everywhere.

Wall-mounted cooling unit TopTherm Blue e, UL Type 3R/4

For efficient outdoor solutions



ENCLOSURES

POWER DISTRIBUTION

CLIMATE CONTROL

IT INFRASTRUCTURE

SOFTWARE & SERVICES



FRIEDHELM LOH GROUP

The perfect solution for indoors and outdoors

Suitable for outdoor installation

- Vandalism-protected (e-Comfort controller on the rear of the cooling unit)
- Outdoor paint finish in accordance with UL 1332

Benefits of the Blue e technology

- Energy savings of up to 45%
- Intelligent control with Comfort controller, icing protection and motor monitoring
- Eco-mode control: Evaporator fan is switched off, where appropriate, in line with the enclosure inside temperature
- Longer service life of components installed in the enclosure and of the cooling unit itself by allowing efficient components such as fans and compressors to run at their optimum operating point
- The integrated electric condensate evaporation ensures that any arising condensate is evaporated and dissipated to the ambient air via the external fan.

Optimum protection

- The cooling units provide protection against damaging influences, e.g. water and external icing.
- The RiNano coating prevents the accumulation of dirt deposits on the condenser, thereby extending maintenance intervals and ensuring a more constant long-term cooling output.

Intelligent networking

- In conjunction with the IoT interface and Blue e adaptor, it is a simple matter to integrate the cooling units into Industry 4.0 environments.
- Condition monitoring of up to 10 cooling units in a master/slave arrangement



1 e-Comfort controller on the rear of the cooling unit

2 Compatible with IoT interface via Blue e adaptor

Temperature range

- -20 °C to +50 °C (in compressor mode +10 °C to +50 °C)

Service

- Worldwide service and spare parts availability

3 Eyebolt (from 1,000 W) for simpler transport and assembly

4 Nano-coated condenser

5 Integral electric condensate evaporation

Protection category

- UL Type 3R/4/12
- IP 56

Approvals

- cULus Listed
- cULus FTTA
- CE
- EAC

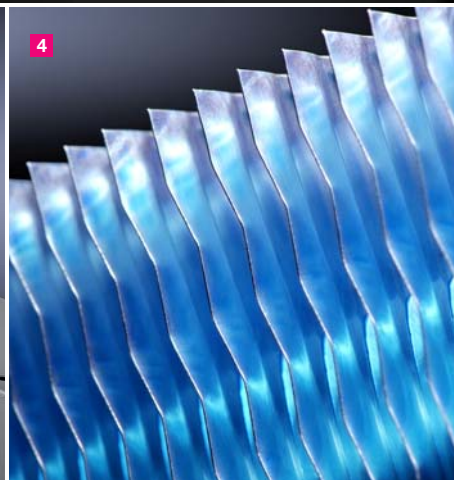

Wall-mounted cooling unit TopTherm Blue e, UL Type 3R/4



Accessories for climate control Page 5

Energy-efficient Blue e wall-mounted cooling units in output categories 500 W to 2,500 W with integral e-Comfort controller, RiNano coating on the condenser and electric condensate evaporation (from 1000 W) as standard, protection category UL Type 3R/4.

Temperature control:

- e-Comfort controller (factory setting +35 °C)

Material:

- Sheet steel

Colour:

- RAL 7035

Protection category IP to IEC 60 529:

- External circuit IP 34
- Internal circuit IP 56

Protection category NEMA:

- UL Type 3R
- UL Type 4
- UL Type 12

Supply includes:

- Nano-coated condenser
 - Fully wired ready for connection (plug-in terminal strip)
 - Drilling template
 - Assembly parts
- Please observe the product-specific scope of supply.

Note:

- Compressor cooling mode from +10 °C ambient temperature. Only the internal fan is active in the temperature range -20 °C to +10 °C.
- Further voltage variants on request.

Approvals:

Available on the Internet

Performance diagrams:

Available on the Internet

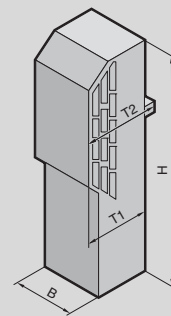

Output class 500 – 2500 W

Model No.	Packs of	3303.508	3303.518	3304.508	3304.548	3305.548	3329.548	Page
Total cooling output 50 Hz L35 L35 to DIN EN 14511 kW		0.46	–	1.1	1.15	1.49	2.43	
Total cooling output 50/60 Hz L35 L35 kW		0.46 / 0.55	0.55	1.1 / 1.26	1.15 / 1.3	1.49 / 1.7	2.43 / 2.57	
Total cooling output 50/60 Hz L35 L50 kW		0.27 / 0.32	0.32	0.9 / 1.07	0.95 / 1.11	1.04 / 1.17	1.68 / 1.71	
Rated operating voltage V, ~, Hz		230, 1~, 50/60	115, 1~, 60	230, 1~, 50/60	400, 3~, 50 460, 3~, 60	400, 3~, 50 460, 3~, 60	400, 3~, 50 460, 3~, 60	
Width (B) mm		285	285	405	405	405	405	
Height (H) mm		620	620	1020	1020	1020	1650	
Depth (T1) mm		298	298	358	358	358	388	
Installation depth of connection box (T2) mm		350	350	410	410	410	440	
Rated current max. A		2.6 / 2.6	5.7	3.9 / 4.3	2.2 / 2.1	2.5 / 2.8	3.7 / 3.8	
Start-up current A		5.1 / 6.4	11.5	12 / 14	11.5 / 12.7	12.2 / 11.3	6.8 / 7.6	
Pre-fuse A		10	10	10	–	–	–	
Motor circuit-breaker A		–	–	–	6.3... 10	6.3... 10	6.3... 10	
Power consumption P _{el} 50/60 Hz L35 L35 kW		0.35 / 0.42	0.42	0.62 / 0.68	0.75 / 0.78	0.65 / 0.82	1.36 / 1.71	
Operating temperature range		-20 °C...+50 °C	-20 °C...+50 °C	-20 °C...+50 °C	-20 °C...+50 °C	-20 °C...+50 °C	-20 °C...+50 °C	
Setting range		+20 °C...+50 °C	+20 °C...+50 °C	+20 °C...+50 °C	+20 °C...+50 °C	+20 °C...+50 °C	+20 °C...+50 °C	
Energy efficiency ratio (EER) 50/60 Hz L35 L35 nach DIN EN 14511		1.31 / 1.3	1.3	1.75 / 1.86	1.53 / 1.67	2.28 / 2.07	1.79 / 1.5	
Refrigerant g		R134a, 170	R134a, 170	R134a, 325	R134a, 325	R134a, 500	R134a, 900	
Weight kg		25.0	25.0	49.0	50.0	52.0	84.0	
Product-specific scope of supply								
Integral electric condensate evaporation		–	–	■	■	■	■	
Accessories								
Door-operated switch	1 pc(s).	4127.010	4127.010	4127.010	4127.010	4127.010	4127.010	
Master/slave cable	1 pc(s).	3124.100	3124.100	3124.100	3124.100	3124.100	3124.100	

IoT interface

The IoT interface is a central component for the intelligent networking of Rittal cooling solutions or sensors for monitoring physical ambient conditions. Equipped with a wide range of interfaces and protocols, it is used to collate and transmit data to super-ordinate IT systems or to systems for the local monitoring of machine statuses.

Benefits:

- Digitalisation and networking offer huge opportunities for every company. With the IoT interface, Rittal cooling solutions and sensors for monitoring physical ambient conditions are easily connected to Industry 4.0 environments without affecting the automation logic.
- Plug and run: The IoT interface is quickly and conveniently configured and commissioned via the integral Web server, no programming required.

Material:

- Plastic to UL 94-V0

Colour:

- RAL 7016

Protection category IP to IEC 60 529:

- IP 20

Supply includes:

- IoT interface
- USB cable (USB-A connector on micro-USB-B connector)
- Angle bracket for Blue e+ cooling unit

Note:

- The IoT interface is only supported by Blue e+ cooling units from firmware version 1.11.0 or above. If applicable, update the firmware using the RiDiag III software (3159.300).
- To interlink cooling units in the Blue e series, the Blue e IoT adaptor (3124.310) is additionally required.



Assembly instruction:

- The IoT interface can be secured on a 35 x 7.5 top hat rail to DIN EN 60715 using a spring-loaded metal clip, or to the rear of a Blue e+ cooling unit using the angle bracket.



Accessories:

- Blue e IoT adaptor, see page 6



W x H x D mm	18 x 117 x 120
For	Blue e+ cooling units Blue e+ chillers Smart Monitoring System for NH fuse-switch disconnectors Rittal sensors
Operating temperature range	+0 °C...+70 °C
Protocols	OPC-UA/SNMPv1/SNMPv2c/SNMPv3/Modbus/TCP/TCP/IPv4/TCP/IPv6/Radius/Telnet/SSH/FTP/SFTP/HTTP/HTTPS/NTP/DHCP/DNS/SMTP/Syslog/LDAP
Interfaces	1 x Micro USB type B (device) for USB 2.0 1 x Micro-SD memory card slot for SD 2.0 1 x USB 2.0 high-speed functions (EHCI) 1 x acknowledgement button 1 x push-in spring connection terminal for NTC sensor 2 x RJ45 jack for RS 485 interface (climate control unit interface)
Network interface	Ethernet IPv4/IPv6 Ethernet to IEEE 802.3 via 10BASE-T, 100BASE-T and 1000BASE-T
Interface bus system	2 x RJ45 CAN bus
Type of electrical connection	Push-in spring connection terminal (24 V DC)
Weight kg	0.278
Packs of	1 pc(s).
Model No.	3124.300

Accessories



Blue e IoT adaptor

In conjunction with the IoT interface, the adaptor supports intelligent networking of cooling units in the Blue e series.

Benefits:

- Digitalisation and networking offer huge opportunities for every company. In conjunction with the IoT interface (3124.300), cooling units in the Blue e series are easily connected to Industry 4.0 environments without affecting the automation logic.
- Plug and run: The IoT interface is quickly and conveniently configured and commissioned via the integral Web server, no programming required.
- Condition monitoring of up to 10 cooling units in the master/slave combination

Material:

- Plastic
- Front: Smooth
- Enclosure: Textured

Colour:

- Front: RAL 9005
- Enclosure: RAL 7035

Protection category IP to IEC 60 529:

- IP 30

Supply includes:

- Blue e IoT adaptor
- Installation and Short User's Guide
- Mounting bracket
- Assembly parts
- Sub-D to RJ11 connection cable
- Mounting clips for securing top-hat rails



Also required:

- IoT interface, see page 5

To fit Model No.	3303.5/6xx/3304.5/6xx/3305.5/6xx/3328.5/6xx/3329.5/6xx/3332.5/6xx/3361.5/6xx/3366.5/6xx/3377.5/6xx/3307.7xx/3310.7xx/3382.5/6xx/3359.5/6xx/3383.5/6xx/3273.500/3384.5/6xx/3385.5/6xx/3386.5/6xx/3387.5/6xx/9776.550
W x H x D mm	80 x 30 x 40
For	TopTherm cooling units with e-Comfort controller
Operating temperature range	+0 °C...+55 °C
Interface bus system	2 x RJ45 CAN bus
Weight kg	0.201
Packs of	1 pc(s).
Model No.	3124.310



Air diverter

For use with wall-mounted cooling units. For targeted routing of cold air in a downward direction. Particularly well-suited for densely-packed electrical components in the lower section of the enclosure.

Material:

- Sheet steel

Colour:

- RAL 7035

To fit Model No.	Installation depth mm	Packs of	Model No.
3304..../3305....	65	1 pc(s).	3213.310
3328..../3329....	65	1 pc(s).	3213.320

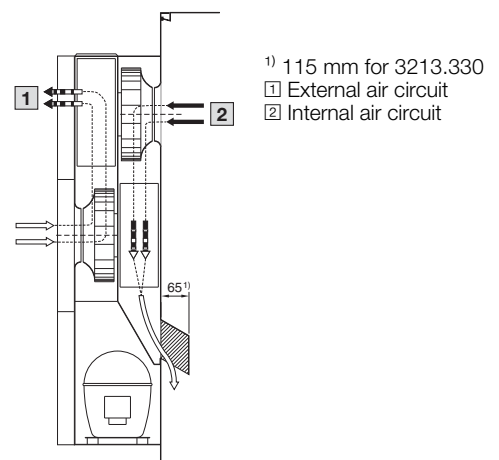

Cooling units of the Blue e generation at a glance



The functionality and degree of protection of Rittal cooling units are always optimally matched to the individual application and the ambient conditions to be expected. Even so, energy accounts for approx. 50% of the total costs over the lifecycle of a cooling unit. This also means that energy offers the greatest potential for savings, however. Make use of the Rittal Blue e technology and benefit from energy savings of up to 45% over the entire lifecycle.

Blue e cooling units

Blue e cooling units, NEMA 4X

Blue e cooling units,
UL Type 3R/4

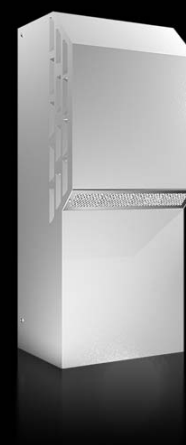

Output range		300 – 4000 W	500 – 2500 W	500 – 2500 W
Protection category	Internal circuit	IP 54	IP 55	IP 56
	NEMA	UL Type 12	UL Type 4X	UL Type 3R/4, UL Type 12
Approval	CE	■	■	■
	EAC	■	■	■
	cURus	■	■	–
	cULus Listed	–	–	■
	cULus FTTA	■	■	■
	GS	■	–	–
	CSA	■	■	–
Temperature range		+10 °C...+55 °C	+10 °C...+55 °C	-20 °C...+50 °C
Outdoor siting		–	–	■
Display		Front	Front	Rear
Material		Sheet steel/stainless steel	Stainless steel 1.4404 (AISI 316L)	Sheet steel (dipcoat-primed)
Installation type	External mounting	■	■	■
	Partial internal mounting	■	–	–
	Full internal mounting	■	–	–

Rittal – The System.

Faster – better – everywhere.

- Enclosures
- Power Distribution
- Climate Control
- IT Infrastructure
- Software & Services

You can find the contact details of all Rittal companies throughout the world here.



www.rittal.com/contact

XWWW00192EN1905

ENCLOSURES

POWER DISTRIBUTION

CLIMATE CONTROL

IT INFRASTRUCTURE

SOFTWARE & SERVICES



FRIEDHELM LOH GROUP