



iN

ARCHI TECTURAL

PERFORMANCE **iN** LIGHTING

PERFORMANCE **in** LIGHTING

Light sculpts the surrounding area to emphasise the meticulous planning that has gone into every piece of architecture. Aesthetics and function combine to create products that are able to satisfy the needs of the most ambitious of projects. Lighting becomes an integral part of the creative and design process, they form the nuances highlighting texture and detail, becoming part of the construction process by perfectly complementing its architectural design.

TYK+



TYK+ 10
6



TYK+ 20
6



TYK+ 30
6

FOCUS+



FOCUS+ ZERO
26



FOCUS+ 1
26



FOCUS+ 2
26



FOCUS+ 3
26

CRICKET+



CRICKET+ 10
42



**CRICKET+ 10
MARINE**
42



CRICKET+ 15
42



CRICKET+ 20
42

STEEL SQUARE



**STEEL
SQUARE 20**
54



**STEEL
SQUARE 28**
54



**STEEL
SQUARE 34**
54

STRIP SQUARE+



STRIP SQUARE+
66



**STRIP SQUARE+
INGROUND**
66

GROOVE



GROOVE 21
108

NOTTURNO



NOTTURNO
80

OMBRA



OMBRA
88

TRACCIA



TRACCIA
96

Q



Q-LIGHT
160

KHA



KHA 5
168



KHA 9
168



KHA SLIM 93
168



KHA SLIM 220
168

INSERT+



INSERT+ ZERO
114

INSERT+ ZERO CLIP
114

INSERT+ 1
114

INSERT+ 2
114

INSERT+ 3
114

MASK+



MASK+ MINI
130

MASK+
130

MASK+ ROUND
130

MIMIK



MIMIK 10
140

MIMIK 20
140

MIMIK 30
140

MIMIK 10 FLAT
140

MIMIK 20 FLAT
140

MIMIK 30 FLAT
140

MIMIK 50
140

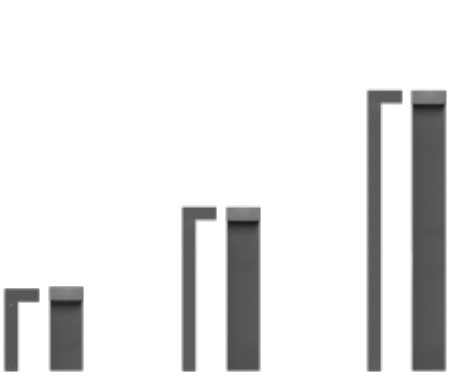

MIMIK 10 POST 300
140

MIMIK 10 POST 600
140

MIMIK 10 POST 1000
140



MIMIK 10 CEILING
140

MIMIK 20 CEILING
140

AMON



AMON WALL
178

AMON MINI
178

AMON MAXI
178

SPILLO



SPILLO MINI POST
190

SPILLO MINI
190

SPILLO
190



CHIAROSCURO

The accent light collection



The “chiaroscuro” begins as a human interpretation of the romantic and conflictive relation between light and shadow and over the time it expanded in several disciplines as a representative technique with a profoundly expressive character.

The “chiaroscuro” will find new applications first in theater and then in movies, by using light that performs three dimensional space by fixing visual hierarchies between backgrounds and characters and by emphasizing its significant value via contrast.

From these artistic experiences the “chiaroscuro”, applied to architectural lighting, finds its narrative power. It

is certain that it is natural light that defines our first spatial condition, but it is artificial light that offers to architecture a communicative capacity of great responsibility.

The “chiaroscuro” can be achieved with an accent lighting to emphasize vegetation, to remark objects or architectural elements to draw the attention in a darker setting by creating hierarchies that allowing a immediate distinction between what is essential and what is not and setting objects visually in the foreground.

TYK+

Shape the nocturnal soul of architecture

TYK+ is the winner of the prestigious Red Dot Design Award.

TYK+ is the quintessence of the structural development in the outdoor architectural field of PERFORMANCE iN LIGHTING. Beauty and essential design, where the proportions remain consistent in the series' different sizes, enrich the luminaire's technical soul. The soul of TYK+ is an elegant blend of the latest technology available in the architectural lighting world. Custom designed optics individually ensure consistent, impeccably precise, yet comfortable light beams.

This product family is a "universal" architectural lighting tool allowing the designer to illuminate horizontal and vertical planes with absolute precision, applying light and shadow strategically to alternate light and dark areas creating a superb project.

Colour change options in RGBW and DALI DT8 tunable white (TW) complete the offer.





TYK+

Long-lasting energy-efficient architectural, landscape and professional flood light series. Fixtures consist of:

Construction

- Die-cast aluminium housing, powder-polyester coated ISO 9227
- High-transparency polycarbonate lenses grant an optimized light transmission
- High resiliency anti-ageing silicone gasket with high elastic return capacity
- Extra-clear, tempered, flat glass diffuser, screen-printed inside
- Diffuser permanently sealed to the housing through a high-temperature resistant silicone
- Stainless steel external screws
- Stainless steel wall-mounting bracket

Electrical

- Built-in driver
- Available with ON-OFF driver and dimmable DALI

Installation

- Graduated goniometer for aiming purposes made in stainless steel
- The snoot accessory is compatible with versions that have C/I narrow-beam lenses

Variants

- For RGBW and white dynamic (TW) versions consult factory

Listings

- CE
- EAC pending
- RCM
- ENEC pending
- Made in Italy

Warranty

- 5-year limited warranty. Complete warranty terms located at www.performanceinlighting.com
- Registered design ®



reddot winner 2021



		TYK+ 10	TYK+ 20	TYK+ 30
CONSTRUCTION				
IP		IP66	IP66	IP66
IK		IK06 1.2J xx3	IK07 4J xx5	IK09 10J xx7
Dimensions (mm)		L 105 x H 131 x D 65	L 203,4 x H 274,5 x D 114	L 275 x H 315,5 x D 114
Weight		Max 1,02 kg	Max 4,42 kg	Max 6,09 kg
Colour		●	●	●
INSTALLATION				
Pre-wired		✓	-	-
Quick		-	-	-
Continuous mounted luminaire		-	-	✓
LED				
Lightsource lumen output	3000 K	650 lm ÷ 1180 lm	3858 lm ÷ 5440 lm	9980 lm
	4000 K	700 lm ÷ 1240 lm	4165 lm ÷ 5880 lm	10650 lm
	rgbw 4000 K	-	1832 lm	-
Luminaire lumen output	3000 K	439 lm ÷ 827 lm	2080 lm ÷ 4660 lm	5149 lm ÷ 8140 lm
	4000 K	473 lm ÷ 893 lm	2245 lm ÷ 5030 lm	5558 lm ÷ 8788 lm
	rgbw 4000 K	-	1485 lm	-
CCT - Correlated Color Temperature		3000 K - 4000 K	rgbw 4000 K - 3000 K - 4000 K	3000 K - 4000 K
CRI / SDCM (macadam step)		80/3	80/3	80/3
Lifetime		L90B10@50000h L90B10@75000h	L90B10@75000h L90B10@94000h	L90B10@50000h
OPTIC				
C/I intensive circle reflector		C/I 10°	C/I 10°	C/I 10°
C/M medium circle reflector		C/M 34°	C/M 34°	C/M 34°
C/IW wide circle intensive reflector		C/IW 65°	C/IW 65°	C/IW 65°
ELL elliptical reflector		ELL 70°x9° ÷ 9°x70°	ELL 35°x65° ÷ 65°x35°	ELL 35°x65° ÷ 65°x35°
ELECTRICAL				
Wattage		7 W - 15 W	35 W - 42 W - 50 W	85 W
Class		I - III	II	II
EEL		-	-	-
Ta MAX° luminaire		40°	35° ÷ 50°	40°
Ta MIN° luminaire		-20°	-40° ÷ -20°	-40°
Dimmable 1-10V		-	-	-
Dimmable DALI		-	✓	✓
Emergency		-	-	-
COSφ ≥ 0,9		-	✓	✓

● AN-96 / Anthracite gray / Textured



○ LDC versions (consult factory)

TYK+ 10



Die-cast aluminium housing, powder-polyester coated ISO 9227



High-transparency polycarbonate lenses grant an optimized light transmission



Graduated goniometer for aiming purposes made in stainless steel



Complete with 1 metre of cable H05RN-F 3G1 mm²



Tear-proof nickelled brass cable gland M16x1.5 for cables Ø 5 mm- Ø 10 mm

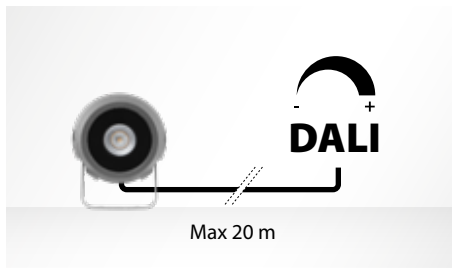

The TYK+ 10 RM versions are in class III, with no output cable and must be powered solely with the power supply units available as accessories.



Dimmable DALI2 power supply units are available, IP66 waterproof in painted die-cast aluminium box or on IP20 plate to be incorporated in waterproof electrical cabinets

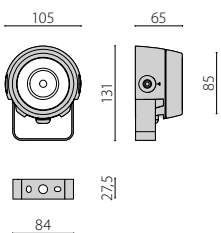



RGBW (consult factory)

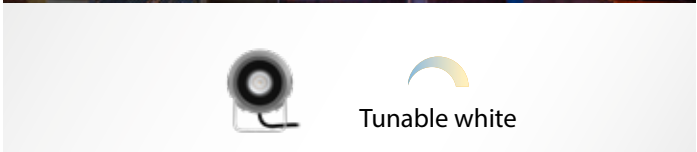

Tunable white (consult factory)

TYK+ 10

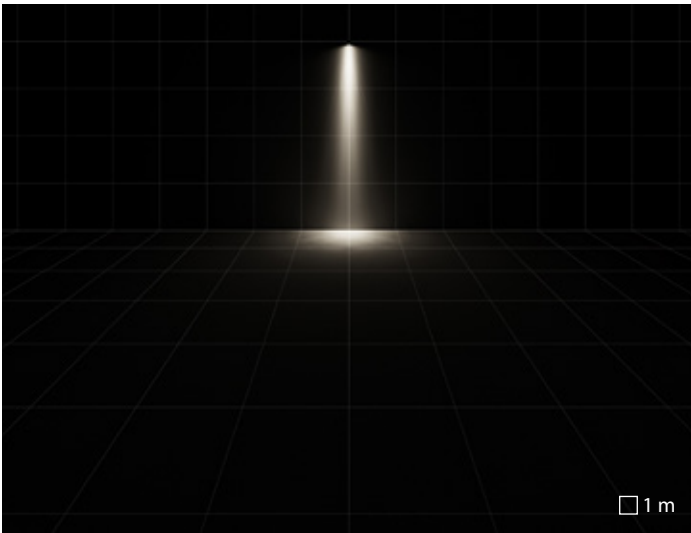

C/I intensive circle reflector

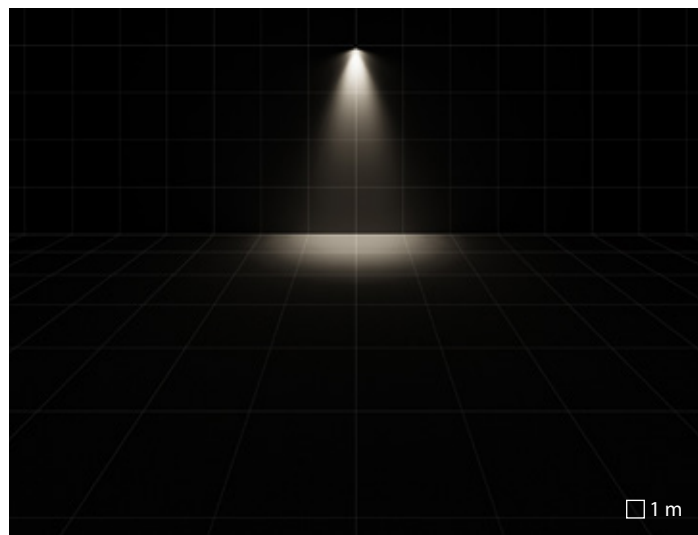
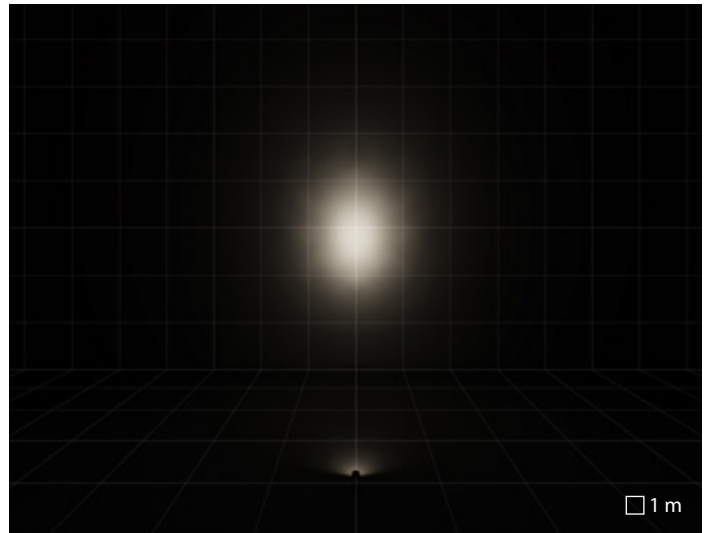

C/M medium circle reflector

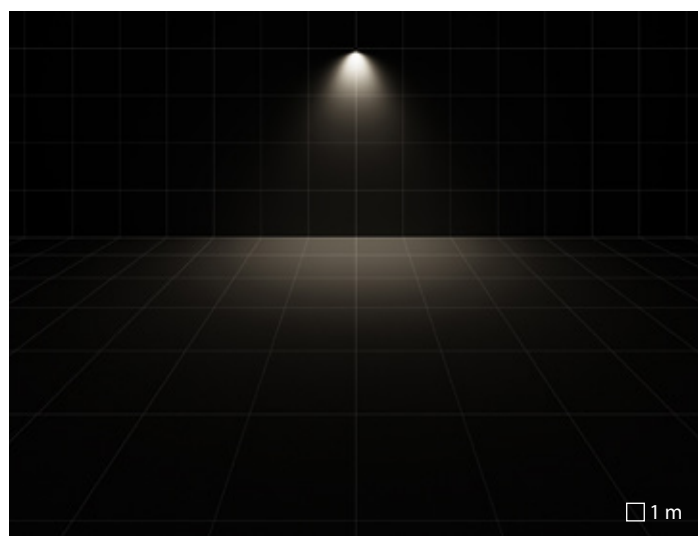
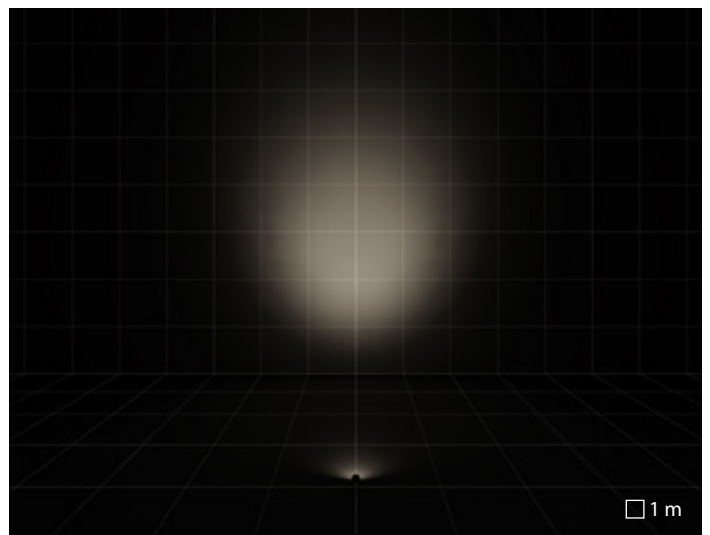

C/W wide circle intensive reflector

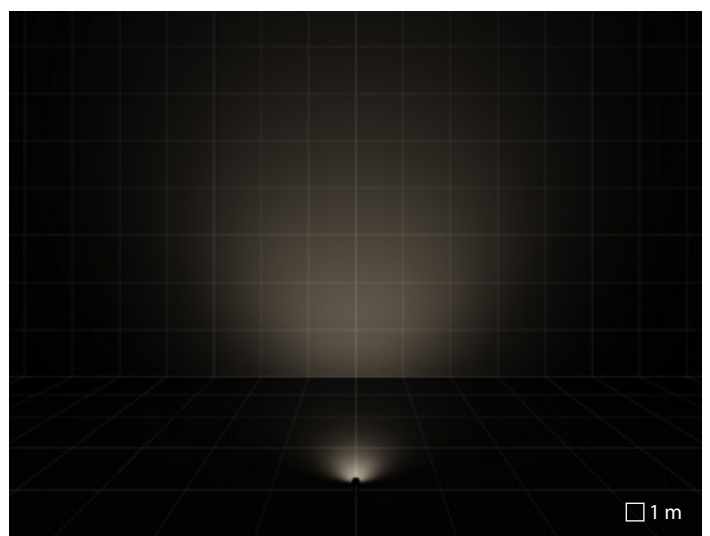

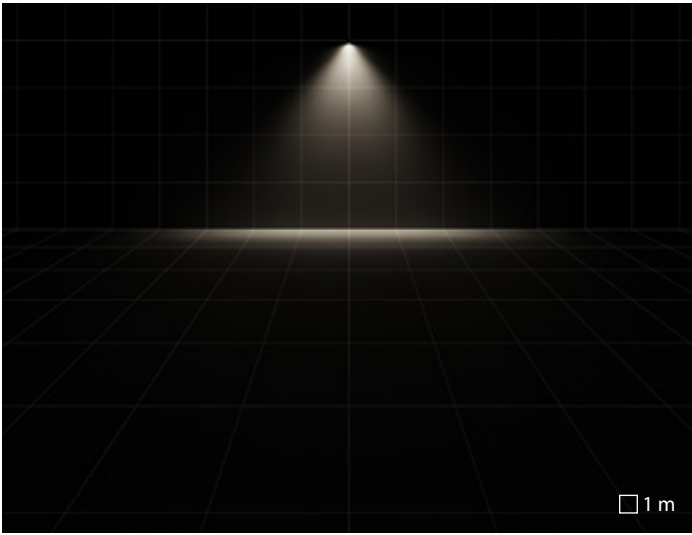

ELL 9°x70° elliptical reflector

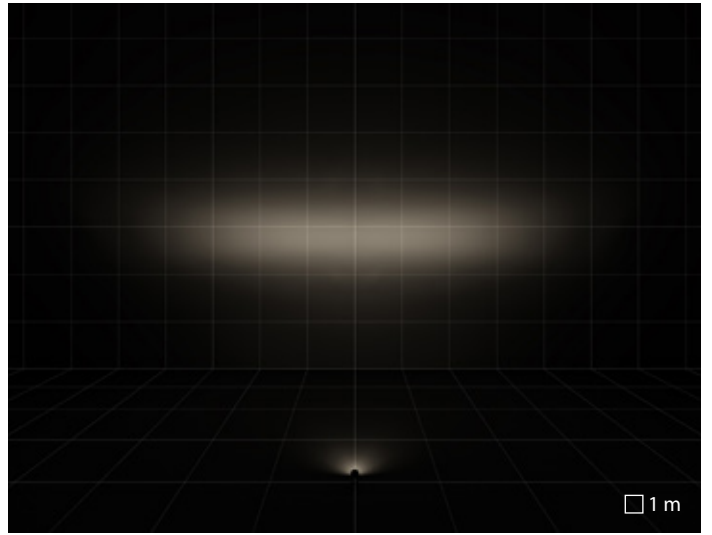

ELL 70°x9° elliptical reflector





Private Villa | Santa Margherita Ligure | Italy

TYK+ 20

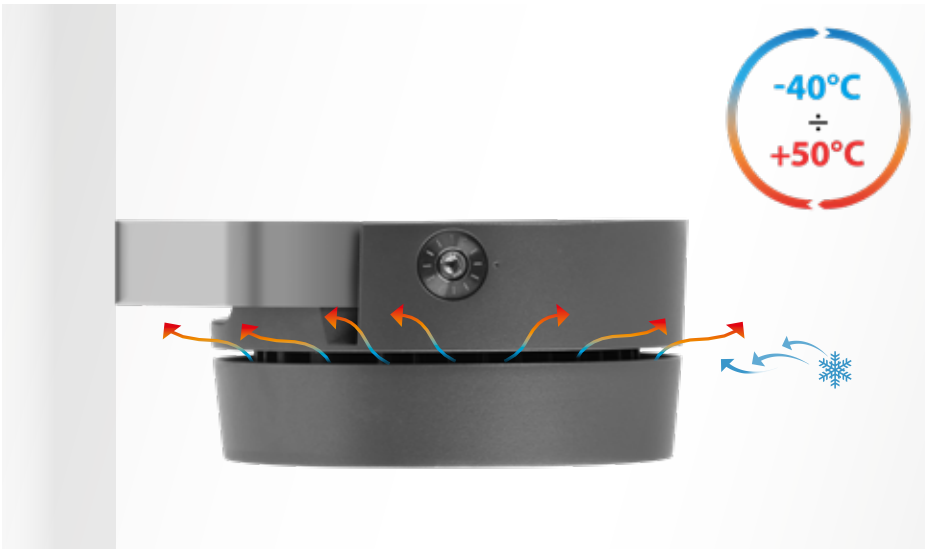

Luminaire designed with two separate die-cast aluminium compartments to maximise heat dissipation between electronic components and the LEDs, powder-polyester coated ISO 9227



High-transparency polycarbonate lenses grant an optimized light transmission



Graduated goniometer for aiming purposes made in stainless steel



Tear-proof nickelled brass cable gland M20x1.5 for cables Ø 10 mm- Ø 14 mm



Drivers with surge protection up to 6 kV (DM)



The snoot accessory is compatible with versions that have C/I narrow-beam lenses

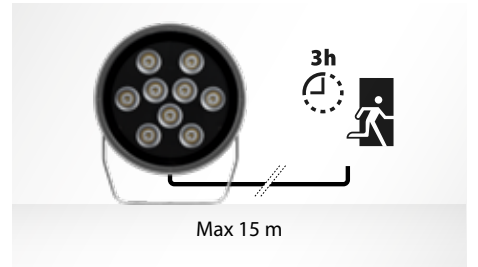

The TYK+ 20 EM3h RM versions are in class II, with no output cable and must be powered solely with the power supply units available as accessories. Consult Factory

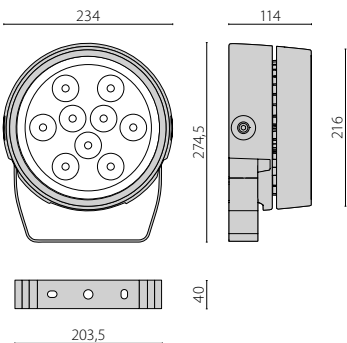



RGBW

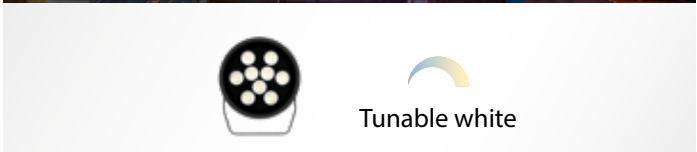

Tunable white (consult factory)

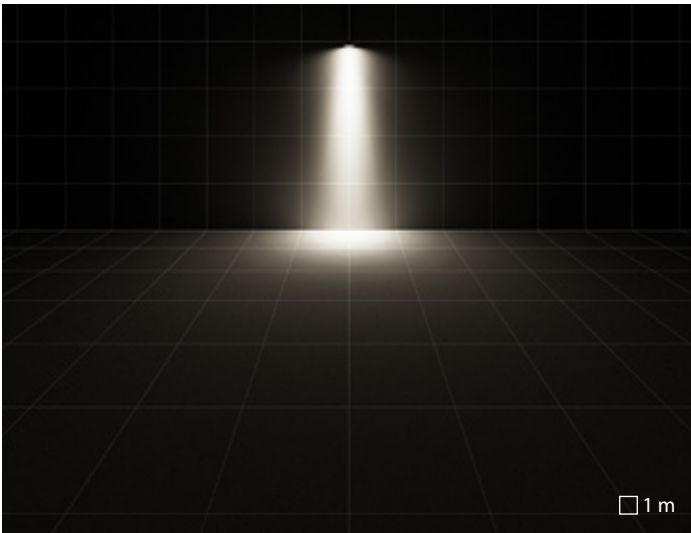

C/I intensive circle reflector

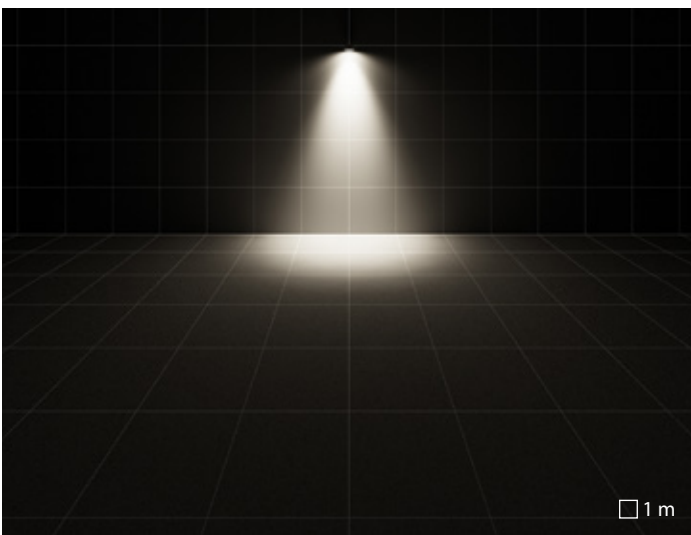
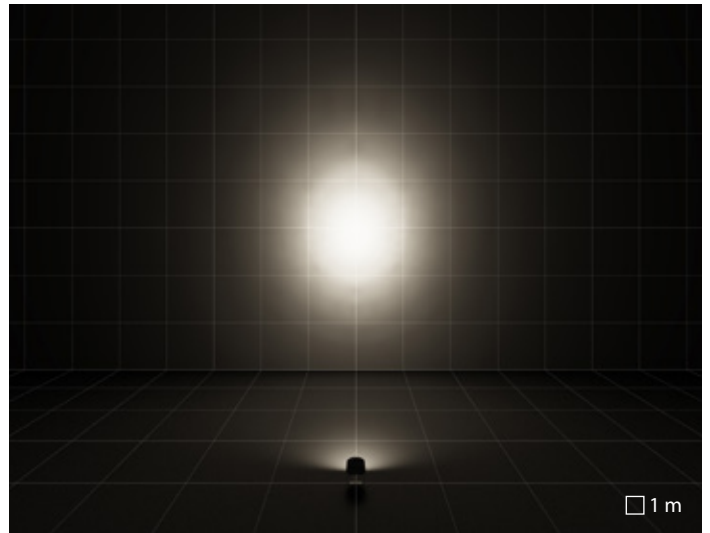

C/M medium circle reflector

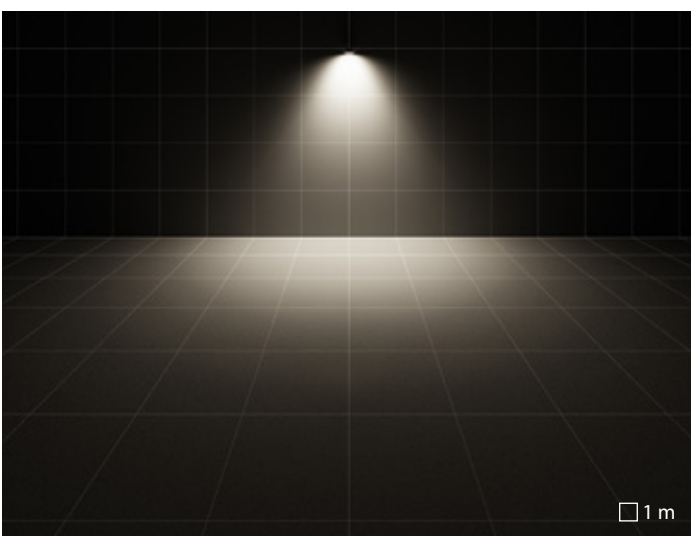
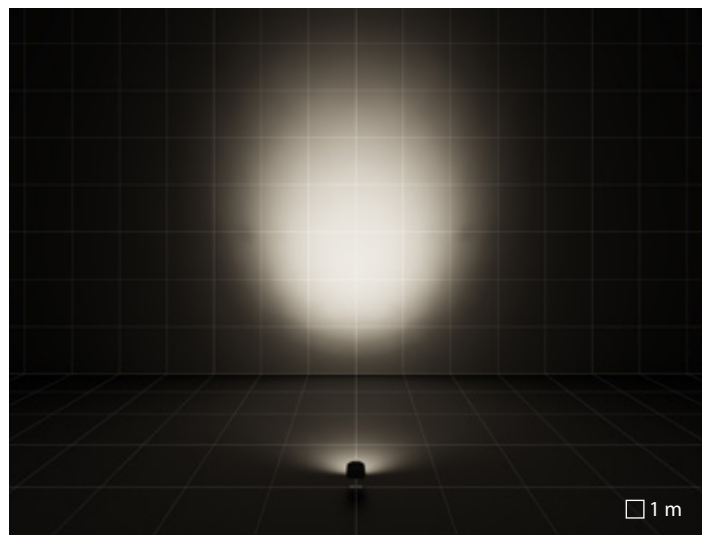

C/W wide circle intensive reflector

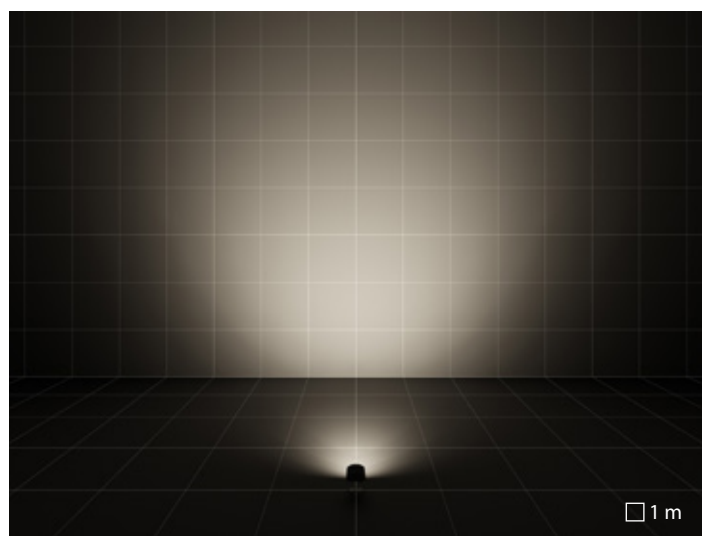

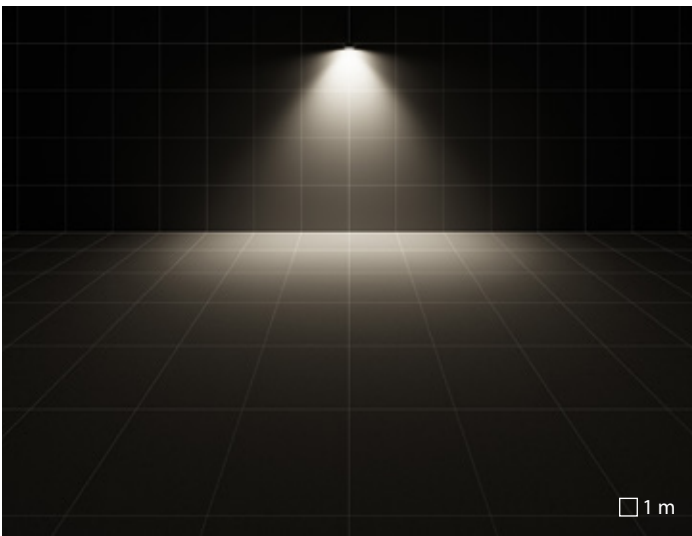

ELL 35°x65° elliptical reflector

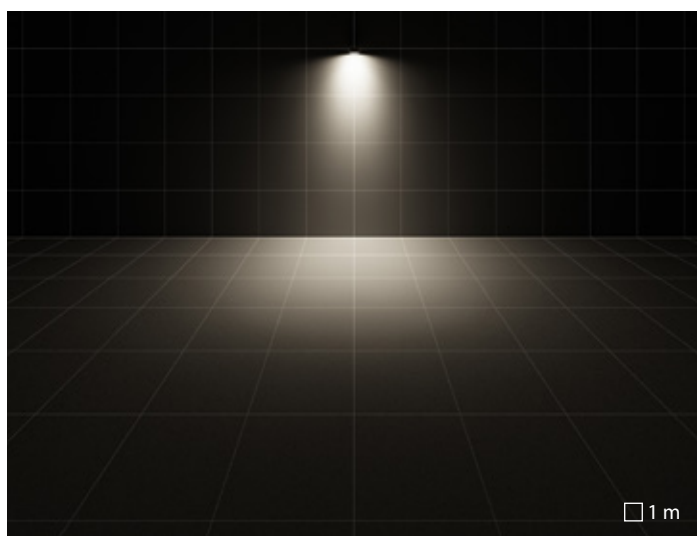
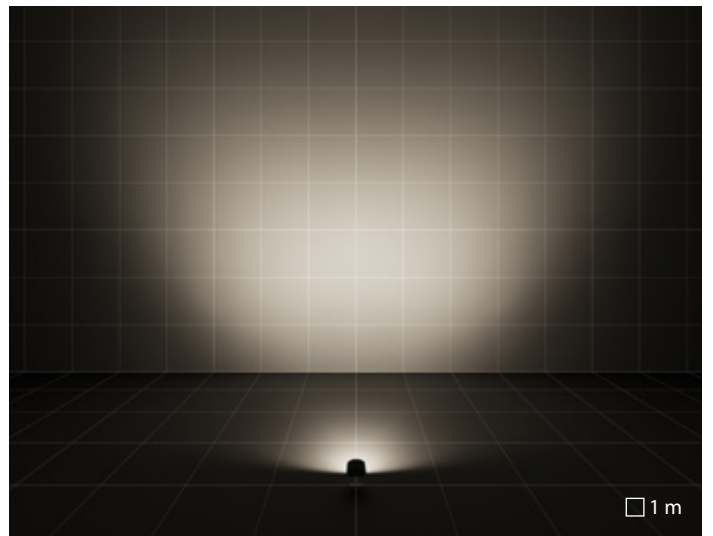

ELL 65°x35° elliptical reflector

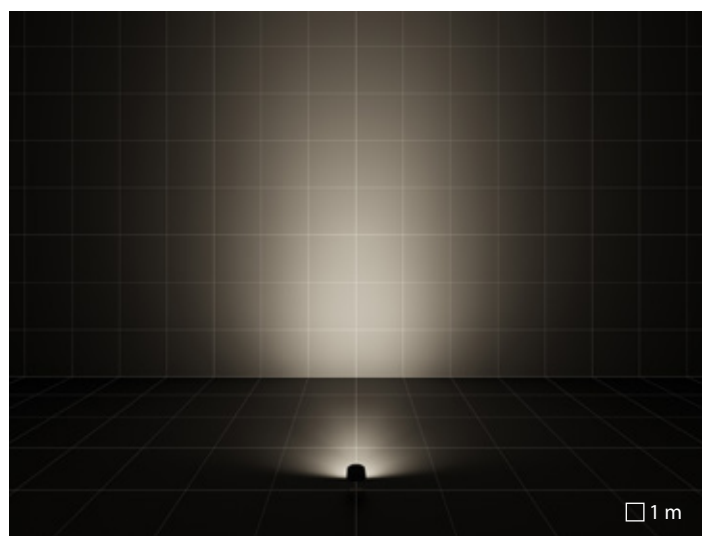

TYK+ 30

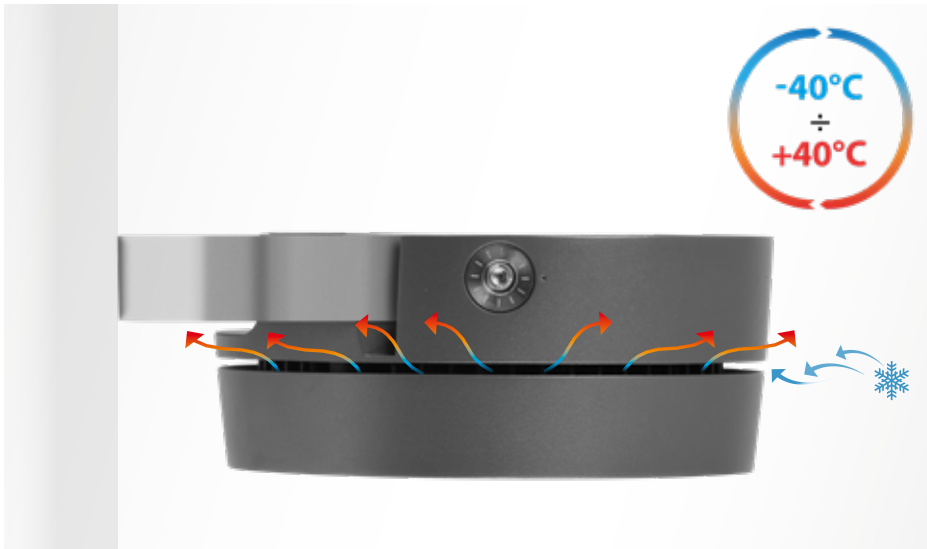

Luminaire designed with two separate die-cast aluminium compartments to maximise heat dissipation between electronic components and the LEDs, powder-polyester coated ISO 9227



High-transparency polycarbonate lenses grant an optimized light transmission

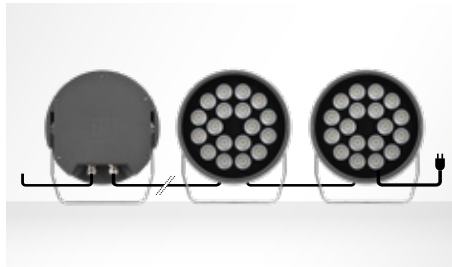

Each luminaire is supplied with two IP 68 cable gland allowing a single or a through power connection



Drivers with surge protection up to 6 kV (DM)



Extra rotation bracket +55°/-90°



Barndoor (consult factory)



Gliding support made of painted aluminium for the installation on 60-76 mm Ø posts. 2 opposed luminaires

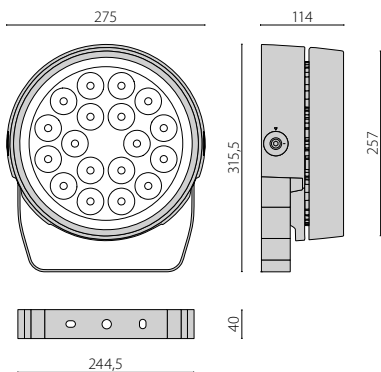



RGBW (consult factory)

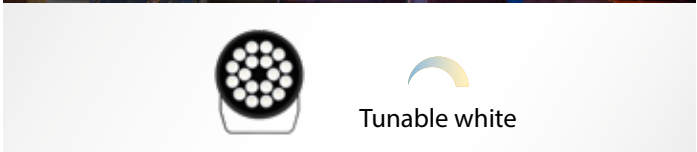

Tunable white (consult factory)

TYK+ 30

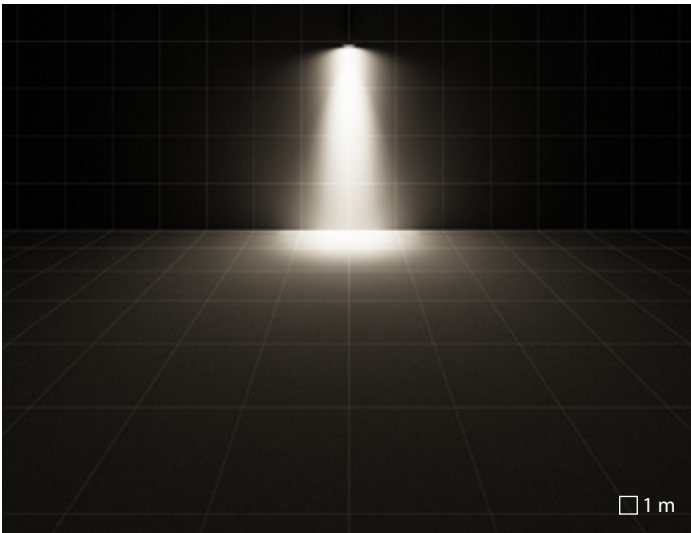

C/I intensive circle reflector

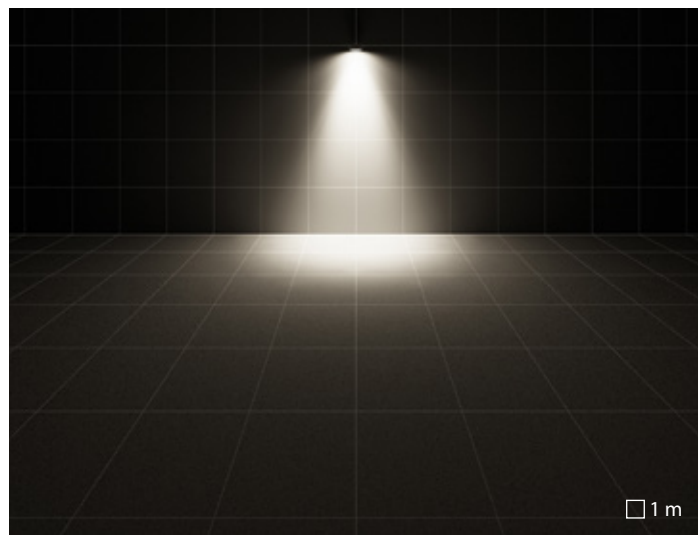
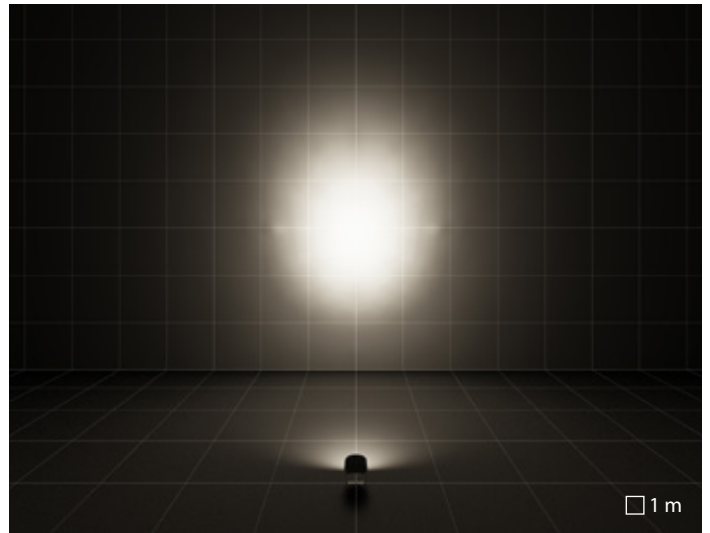

C/M medium circle reflector

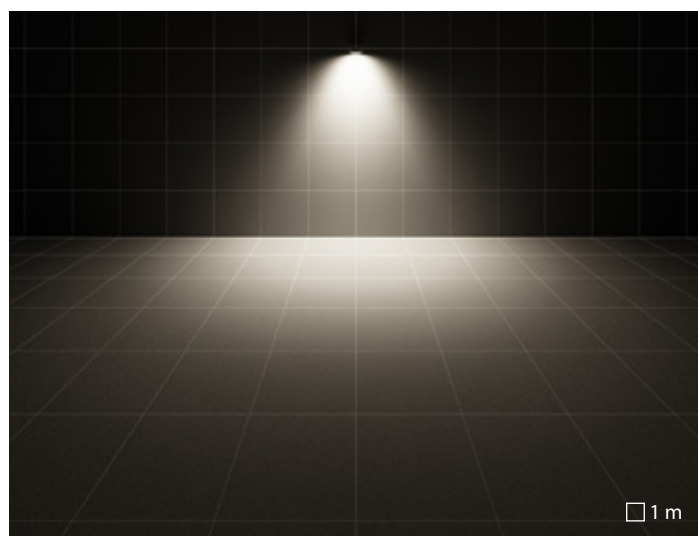
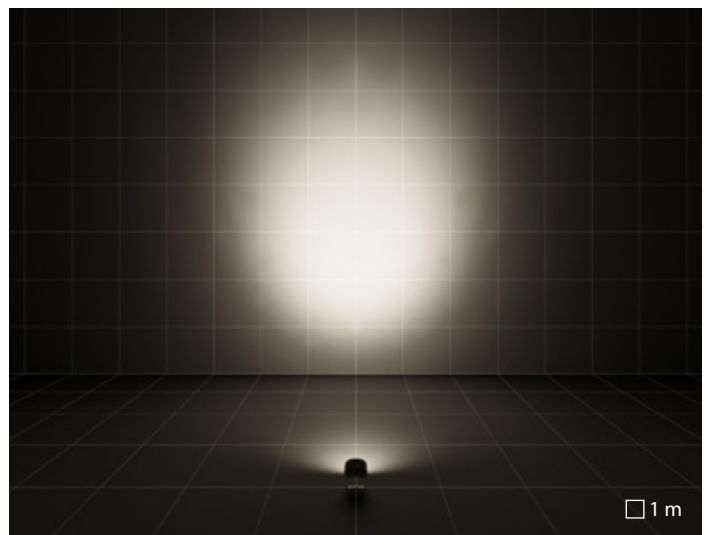

C/W wide circle intensive reflector

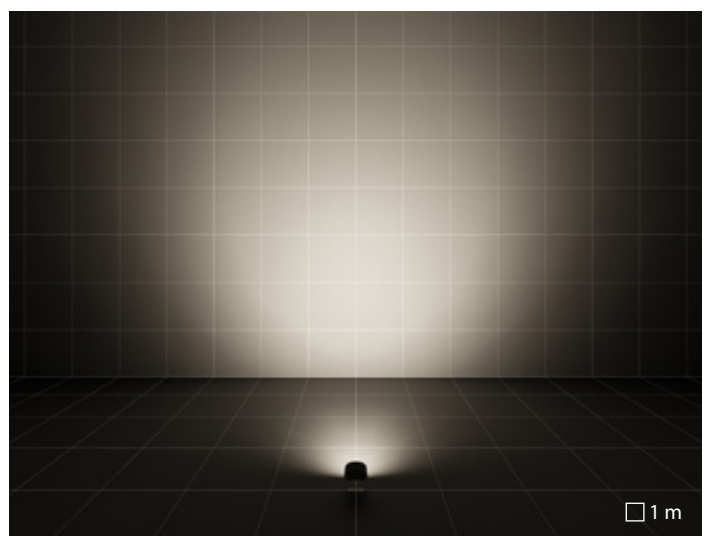

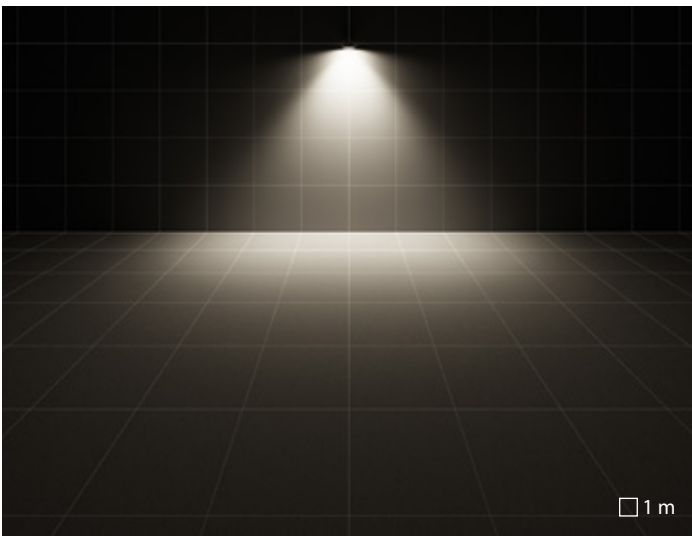

ELL 35°x65° elliptical reflector

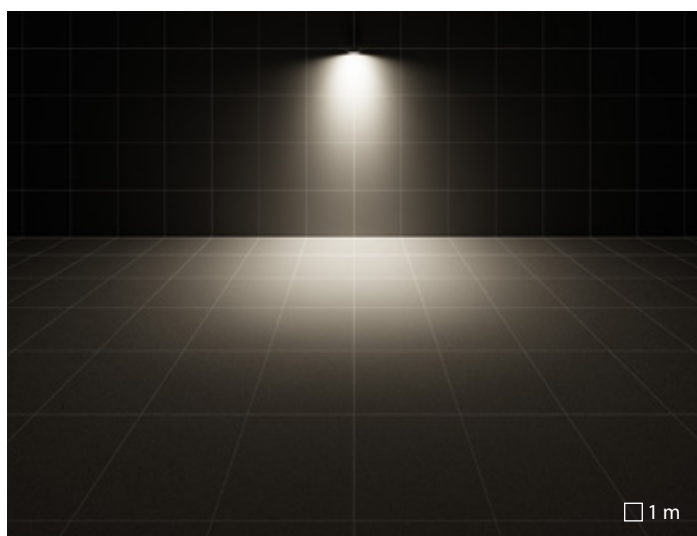
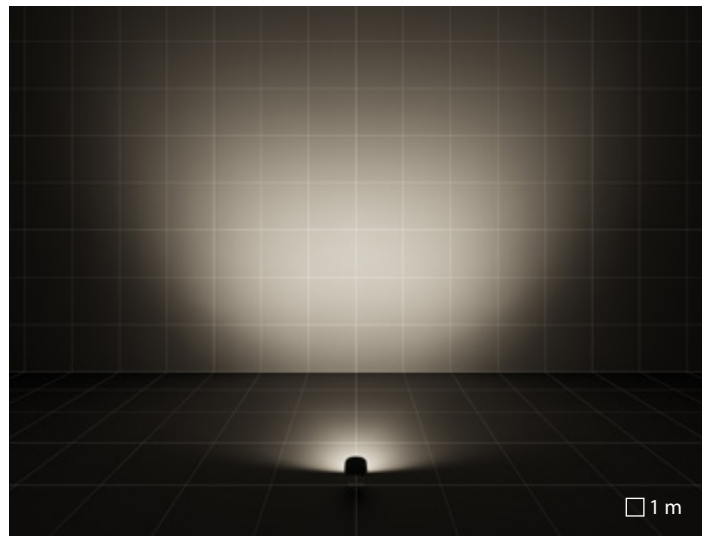

ELL 65°x35° elliptical reflector

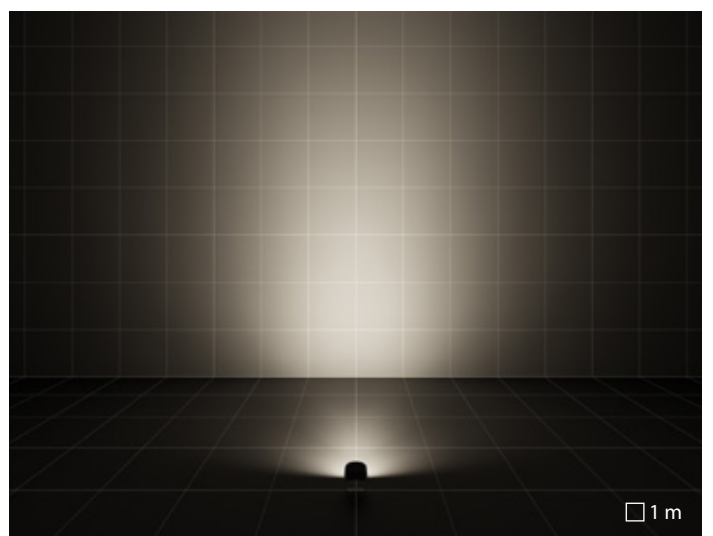

FOCUS+

Enhance every detail

Artificial light plays an essential role in the environment during night-time: it provides orientation, transmits mood and emotion, draws attention.

FOCUS+, a series of luminaires designed to offer high performance with LED sources amongst the most efficient and updated in the marketplace, is functional and an intelligent choice for today's lighting needs. FOCUS+ is an excellent choice of compact floodlights specifically suited to enhance architectural details, to illuminate vertical and horizontal surfaces as well as other typical structural landscape needs. The range of beam distributions and wattages offers various options to enhance your project.

Technology, compactness and efficiency are the core elements to build the best solution for each nocturnal architecture. This series offers indeed a universe of possibilities, where the only greatness is light.

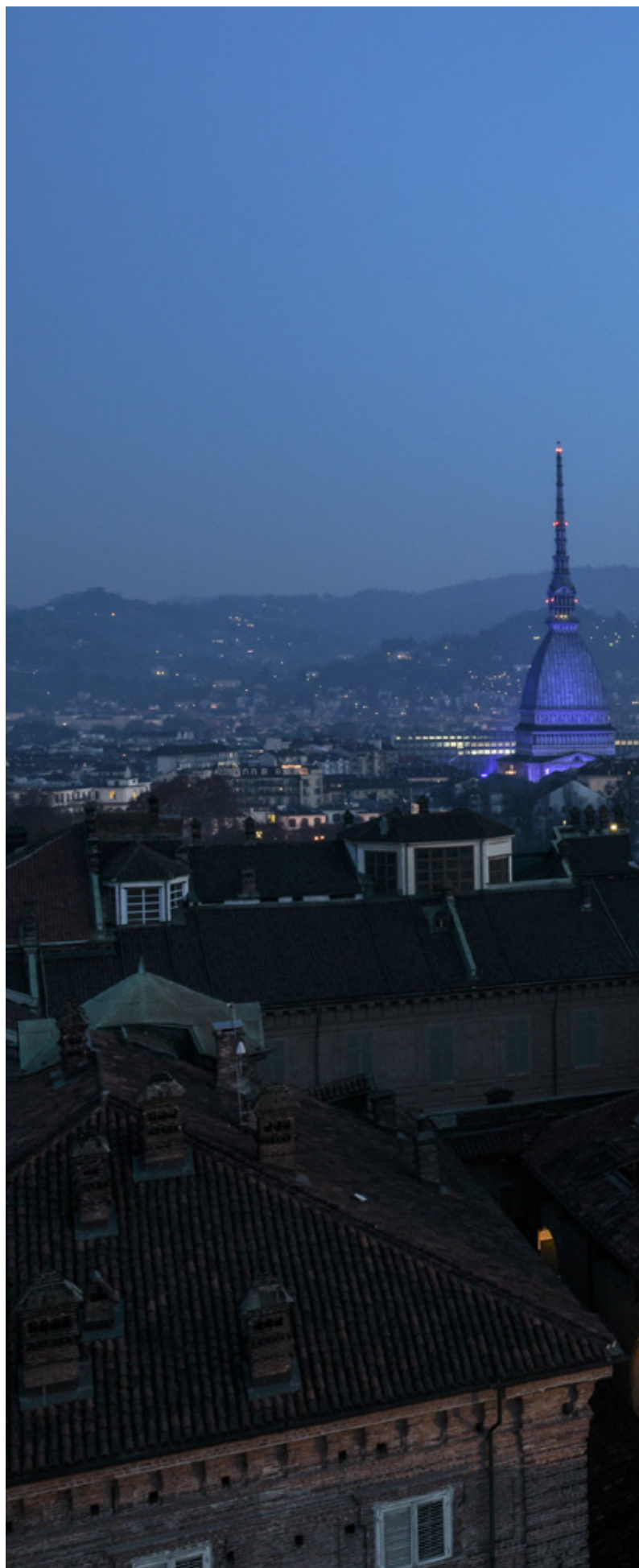



Chapel of the Holy Shroud | Turin | Italy

FOCUS+

Long-lasting energy-efficient architectural, landscape and professional flood light series. Fixtures consist of:

Construction

- Die-cast aluminium housing and trim, powder-polyester coated ISO 9227
- Anti-ageing silicone gasket
- Extra-clear, tempered, flat glass diffuser, screen-printed inside
- Stainless steel locking screws
- Adjustable mounting bracket made of die-cast aluminium, painted

Electrical

- Built-in driver

Installation

- The FOCUS+ZERO KIT versions are complete with 3 metres of cable H05RN-F 3G1 mm²
- Cable gland M20x1.5 for cables Ø 7- Ø 12 mm (FOCUS+ 2 / 3)

Variants

- Versions with 1-10 V dimmable ballast available (FOCUS+ 1 / 2 / 3). Consult Factory

Listings

- CE
- EAC
- RCM
- ENEC
- Made in Italy

Warranty

- 5-year limited warranty. Complete warranty terms located at www.performanceinlighting.com
- Registered trademark®





FOCUS+ ZERO

FOCUS+ ZERO KIT

CONSTRUCTION			
IP		IP65	IP65
IK		IK06 1J xx3	IK06 1J xx3
Dimensions (mm)		L 80 x H 132 x D 30	L 80 x H 432 x D 61
Weight		max 0,5 kg	max 0,69 kg
Colour		●	●
INSTALLATION			
Pre-wired		1 m	3 m
Quick		-	-
Water Stop		-	-
Continuous mounted luminaire		-	-
LED			
Lightsource lumen output	3000 K	1350 lm	1350 lm
	4000 K	1485 lm	1485 lm
Luminaire lumen output	3000 K	611 lm	611 lm
	4000 K	634 lm	634 lm
CCT - Correlated Color Temperature		3000 K - 4000 K	3000 K - 4000 K
CRI / SDCM (macadam step)		80/3	80/3
Lifetime		L70B10@35000h	L70B10@35000h
OPTIC			
S/EW symmetric extra wide reflector		S/EW	S/EW
A/M asymmetric medium reflector		-	-
A/W asymmetric wide reflector		-	-
C/I intensive circle reflector		-	-
C/M medium circle reflector		-	-
C/W wide circle reflector		-	-
ELL elliptical reflector		-	-
ELECTRICAL			
Wattage		10 W	10 W
Class		I	I
EEL		-	-
Ta MAX°C luminaire		25°C	25°C
Ta MIN°C luminaire		-20°C	-20°C
Dimmable 1-10 V		-	-
Dimmable DALI		-	-
Emergency		-	-
COSφ ≥ 0,9		✓	✓

● AN-96 / Anthracite gray / Textured



FOCUS+ 1

FOCUS+ 2

FOCUS+ 3

IP66	IP66	IP66
IK06 1J xx3	IK09 10J xx7	IK09 10J xx7
L 160 x H 223 x D 43	L 220 x H 300 x D 50	L 220 x H 300 x D 50
max 1,5 kg	max 3 kg	max 3,06 kg
●	●	●
-	-	-
-	-	-
-	-	-
✓	✓	✓
1680 lm	2520 lm	5040 lm
1880 lm	2820 lm	5640 lm
1108 lm ÷ 1307 lm	1824 lm ÷ 2052 lm	3409 lm ÷ 3964 lm
1239 lm ÷ 1462 lm	2037 lm ÷ 2292 lm	3807 lm ÷ 4428 lm
3000 K - 4000 K	3000 K - 4000 K	3000 K - 4000 K
70/3	70/3	70/3
L70B10@60000h	L70B10@60000h	L70B10@60000h
-	-	-
A/M 10°	A/M 10°	A/M 10°
A/W 55°	A/W 55°	A/W 55°
C/I 17°	C/I 17°	C/I 17°
C/M 34°	C/M 34°	C/M 34°
C/W 56°	C/W 56°	C/W 56°
ELL 15°x40°	ELL 15°x40°	ELL 15°x40°
18 W	26 W	49 W
I	I	I
A1 - A2	A1 - A2	A1 - A2
40°C ÷ 35°C	40°C ÷ 35°C	30°C
-20°C ÷ -25°C	-20°C ÷ -25°C	-20°C ÷ -25°C
-	-	-
✓	✓	✓
-	-	-
✓	✓	✓

FOCUS+ ZERO

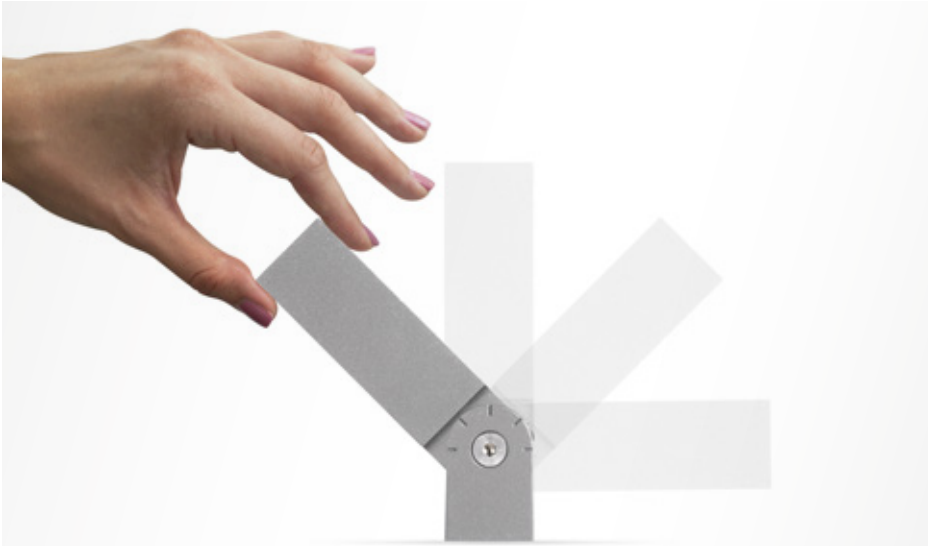

Rotation $\pm 95^\circ$.



Aluminium reflector.

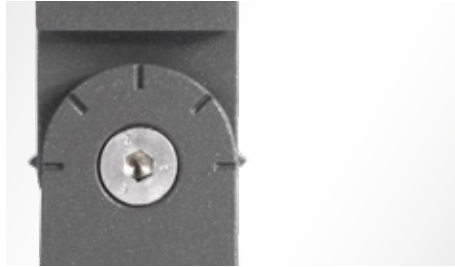

Adjustable mounting bracket made of die-cast aluminium.



Pre-wired with 1m H05RN-F cable.



KIT available.

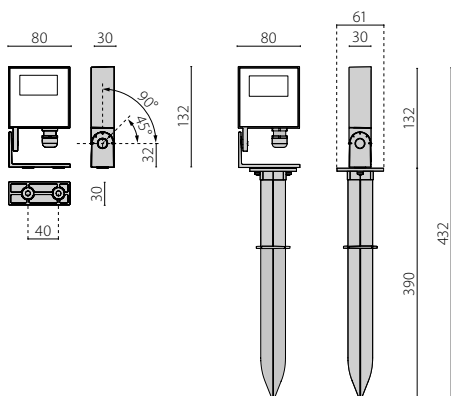

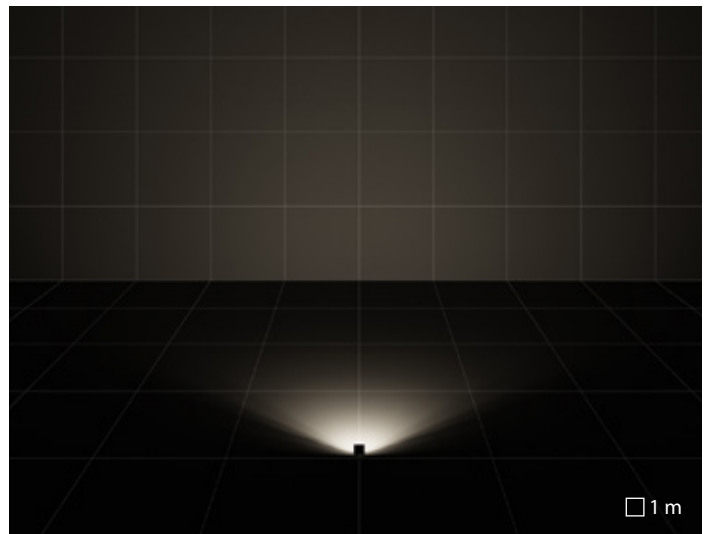
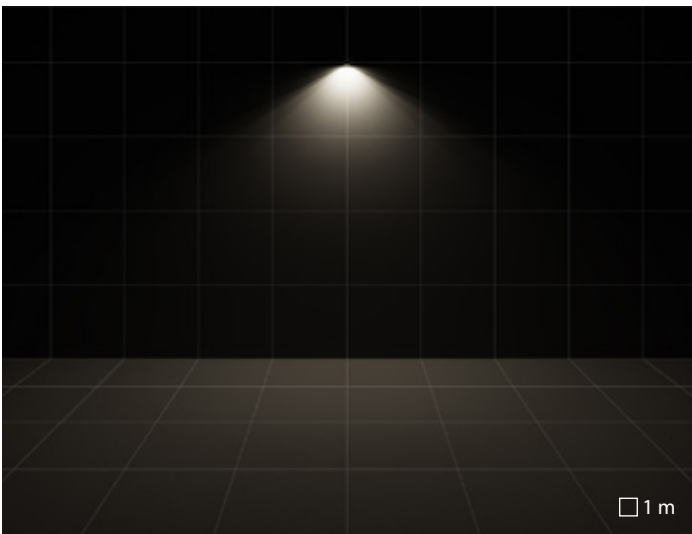

S/EW symmetric extra wide reflector

FOCUS+ 1/2/3

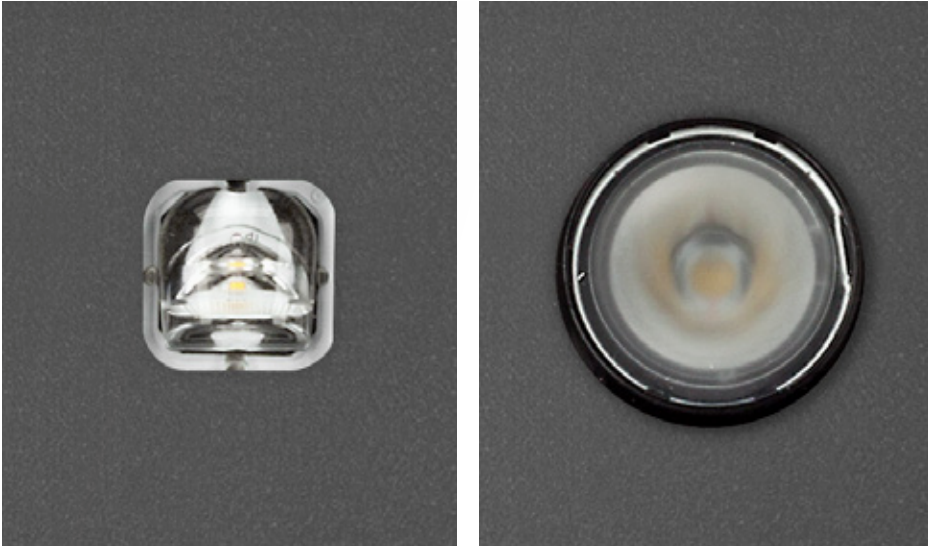

Equipped with high-transmittance polycarbonate lenses with different light distributions to meet the most diverse lighting requirements.



Heat sink. (FOCUS+ 2 / 3)

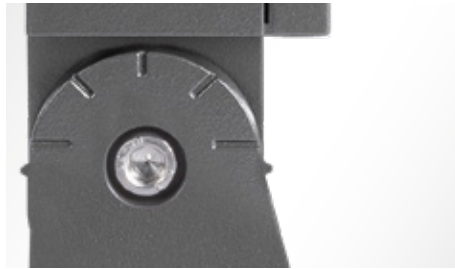

Adjustable mounting bracket made of die-cast aluminium.



Factory wired for through wiring.

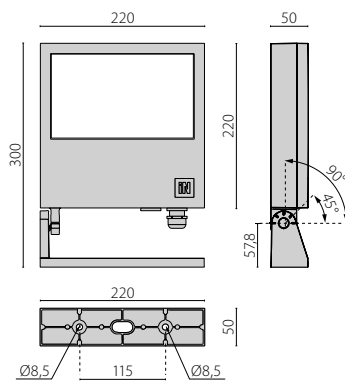
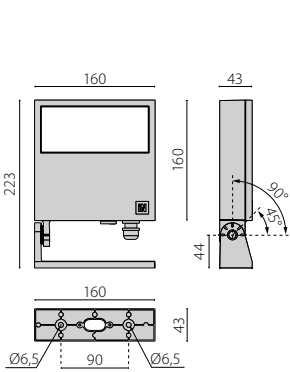



Dymaeon Wall | Patras | Greece

FOCUS+ 1/2/3

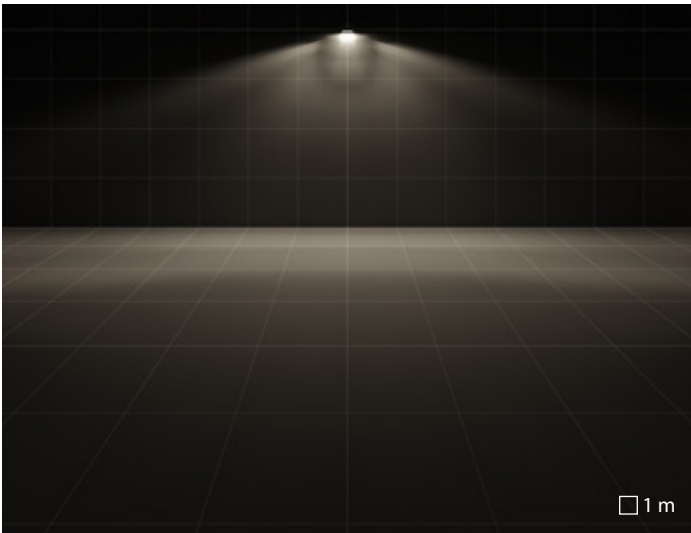

A/M asymmetric medium reflector

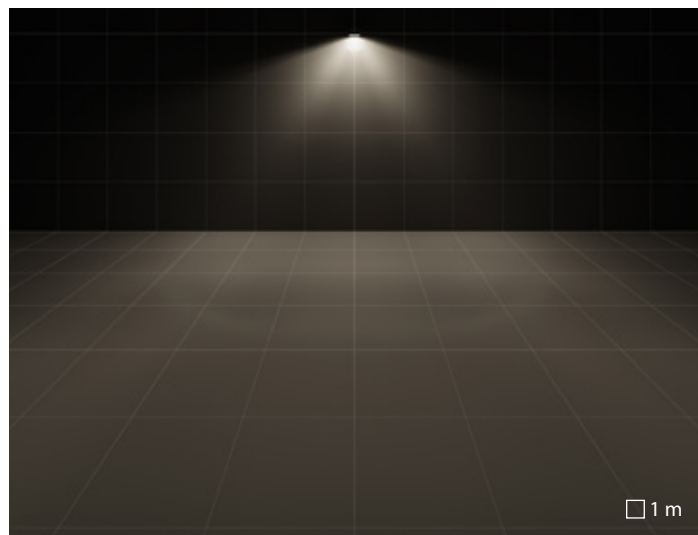
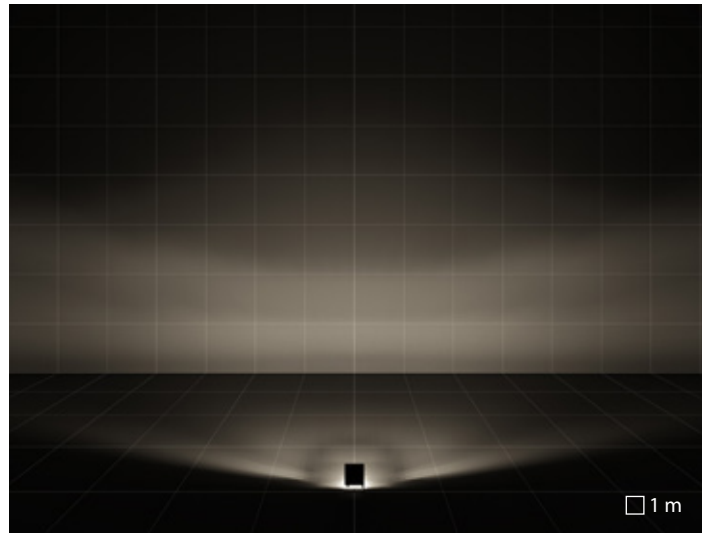

A/W asymmetric wide reflector

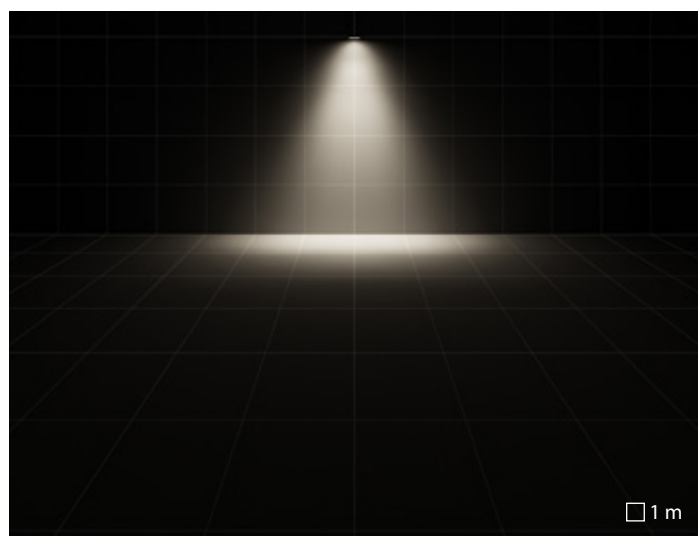
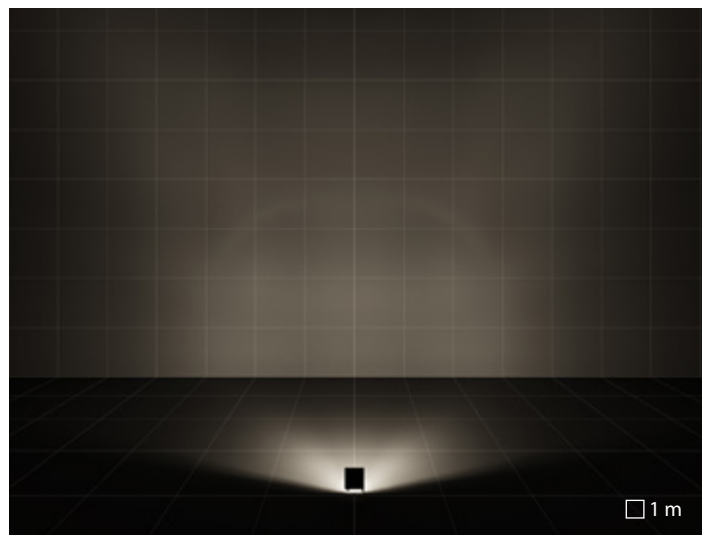

ELL elliptical reflector

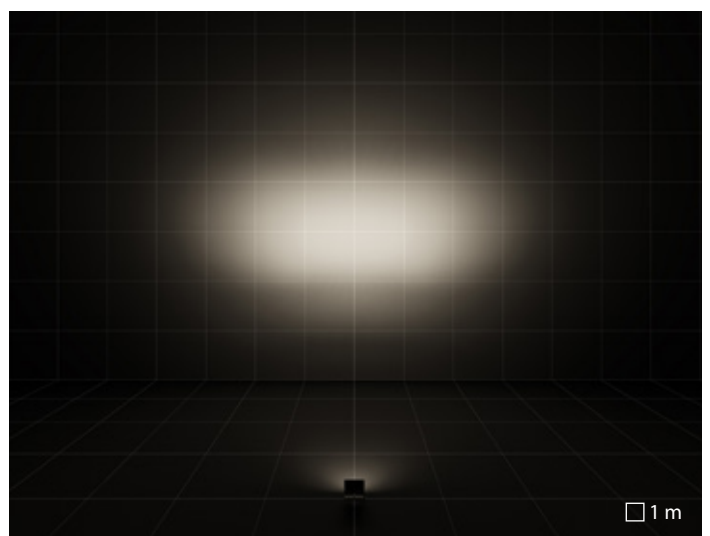

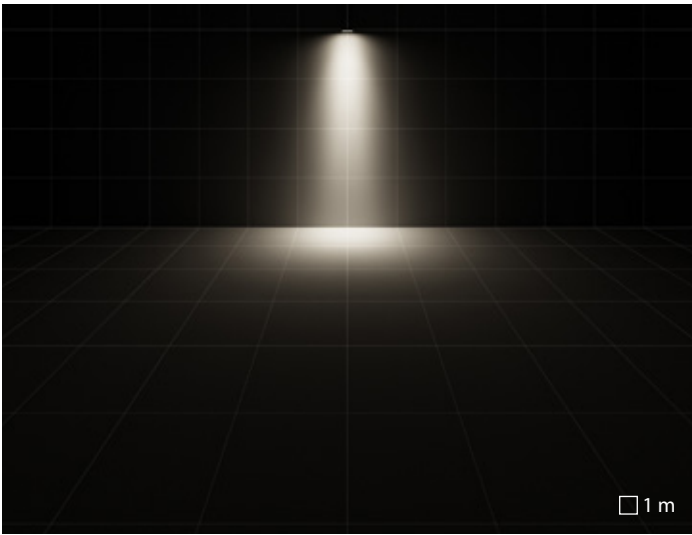

C/I intensive circle reflector

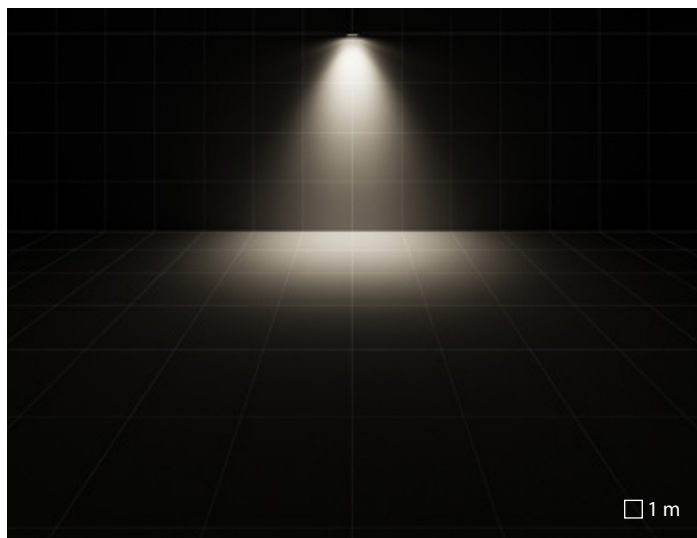
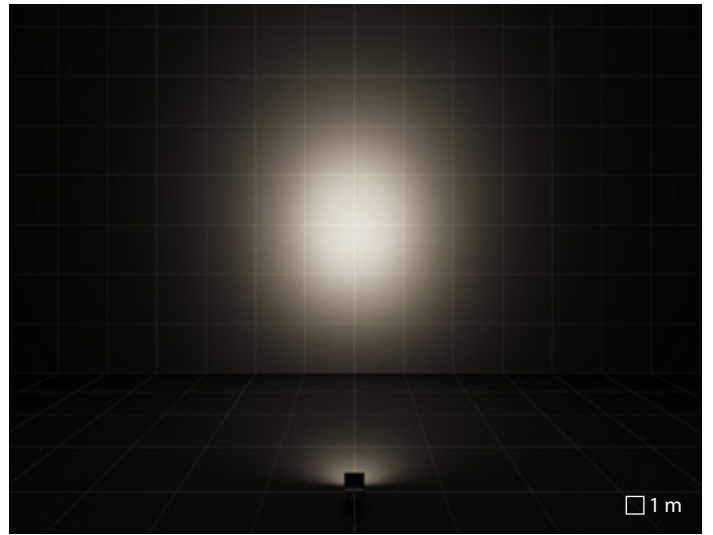

C/M medium circle reflector

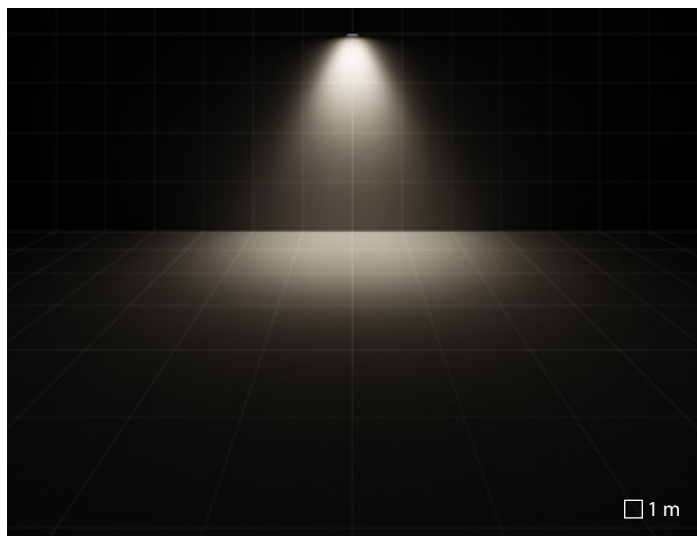
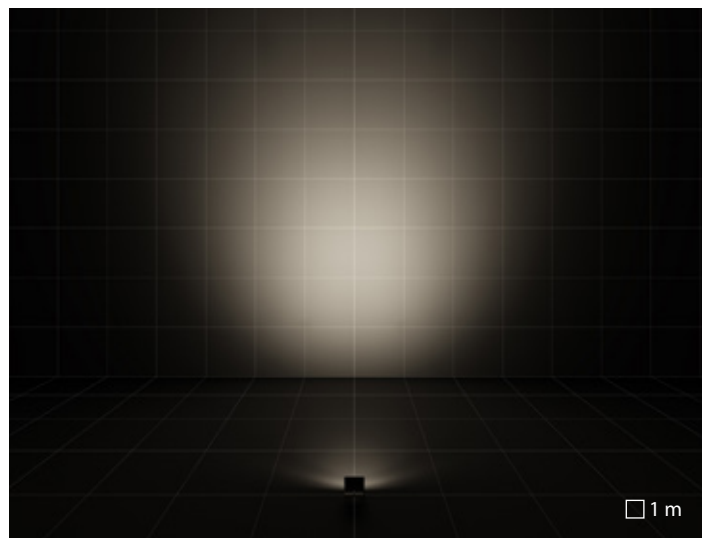

C/W wide circle reflector

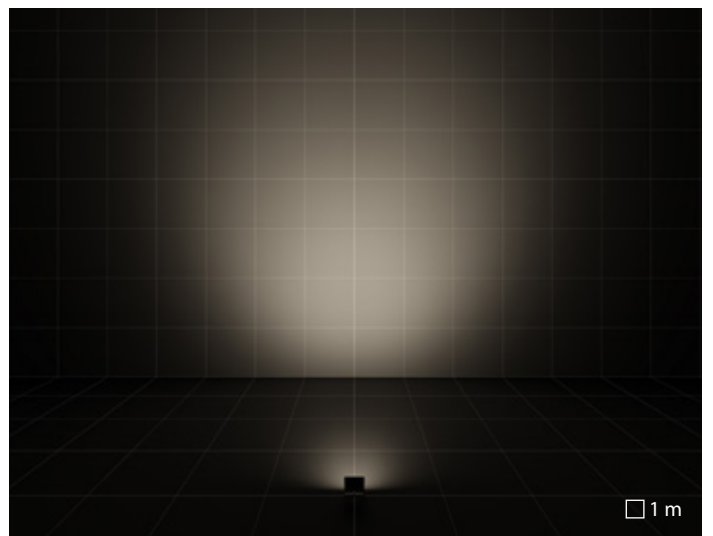





Church of St. George in Braida | Verona | Italy

PLACES OF WORSHIP

Lighting places of worship in past centuries were entrusted by natural light, which, filtering through the windows, takes on a symbolic meaning, becoming an expression of the divine, in opposition to the dark matter. A place of worship contains two worlds: one linked to the celebration of the liturgy and one related to the exaltation of architecture and works of art. There is no lighting regulation defined yet for sacred sites, be they churches, mosques, synagogues, temples or sanctuaries. Important is to preserve visual comfort, providing luminaires with correct colour rendering index and not too cold light tones. In this way, the location looks at an intimate and enveloping place suitable for the purpose.



Parish Complex | Varignano - Viareggio | Italy

ALTAR

Leading role for the eucharistic celebration, the focal point for the devoted. In correspondence with this area, both for horizontal and vertical surfaces, it's enough to reach from 300 to 400 average lux. Other elements to highlight are the ancon, or the altarpiece depicting the saint to whom the church is dedicated, and the ambo, a raised tribune used for reading sacred texts or preaching. During the function, on the ancon keep at least 200 lux average, paying attention to the positioning of the luminaires to avoid reflections on the pictorial surface, while on the ambo 300 lux average are recommended.



Church of the Blessed Virgin Mary | Borgo Nuovo - Verona | Italy

ASSEMBLY

To properly illuminate the assembly of devoted, it's necessary to consider the two phases of the liturgical function: the liturgy of the word and the liturgy of the Eucharist.

The light must be able to create a comfortable environment, allowing at the same time the reading of the passages and the gathering of the devoted. It is recommended to obtain between 150 and 200 lux on the horizontal plane and, in proportion, between 30 and 50 lux on the vertical surfaces, through the use of zenith lighting and medium-light beams opening (between 20 and 45 degrees). Regulate the illumination to emphasise more the two phases, creating more or less sharp contrasts.



Chapel of the Holy Shroud | Turin | Italy



Church of St. George in Braida | Verona | Italy

ARCHITECTURE

At the end of the religious function, the building returns to be architecture. In this case, the light will have to highlight elements and forms that characterise the architecture, such as vaults, domes and chapels. Lighting up these elements as evenly as possible and avoiding unpleasant “smudges” of light on the walls. Where possible, install the products above the vault directing them towards the opposite half of the vault using medium-wide openings from 45 to 75 degrees optics. Alternatively, opt for suspended systems, not too invasive, which integrate the projectors.

WORKS OF ART

Great attention must be given to the lighting of works of art, be they paintings or sculpted pieces. To avoid light sources’ reflection on surfaces place them outside of what is called “offence volume”. The light must be directed towards the work in a not too grazing way, with angles not exceeding 70 degrees. For sculptural works, it is generally advisable to prefer lighting from above, which takes into account the shape of the object. In terms of colour temperature, it is preferable to opt for the shade closest to the colour that characterises the work, to enhance its chromatic contents.

CRICKET+

Earthly light

CRICKET+ blossoms in darkness. Walkable and drive-over elements, with an elegant and refined design made with the highest quality materials, guarantee professional lighting effects. Positioned at ground level, the upward light direction immediately draws attention. CRICKET+ is perfect for lighting architectural structures, monuments, sculptures, trees, marking pathways and lighting entrances.

With trim options of both aluminum and stainless steel, various optics, optional non-slip and frosted glass.

The solid-brass version is suitable for seaside installation, ideal for saline and windswept settings (CRICKET+ 10 MARINE).

Colour change options in RGBW and DALI DT8 tunable white (TW) complete the offer.

CRICKET+ will become the perfect solution to your in-ground needs: supreme materials, versatile and designed for easy installation and maintenance.





Private Villa | Sayad | France

CRICKET+

In-ground series. Fixtures consist of:

Construction

- Black painted anodised die-cast aluminium housing
- Powder polyester painting process optimised against UV rays in 13 different steps guaranteed ISO9227 against salt spray 1000 hours
- Die-cast aluminium trim painted coated with AISI 316 stainless steel (versions INOX)
- Aluminium heat sink
- High-transparency polycarbonate lenses grant an optimized light transmission
- High resiliency anti-ageing silicone gasket with high elastic return capacity
- Extra clear, tempered, flat glass diffuser
- Stainless steel external screws

Electrical

- Available with ON-OFF driver and dimmable DALI

Installation

- Mains connection device WATER STOP
- Recessed housing manufactured from technopolymer. Order separately
- Technopolymer recessed casing available as an accessory to guarantee driveability and designed to favour water drainage through the WATER DRAIN system
- If the device is accessible to the public, it is advisable to ensure that the glass temperature is compatible with the prevailing local installation standards. The temperature is indicated on the website, on the data sheet of each item.
- For outdoor applications, provide drainage gravel for at least 300 mm additional to the appliance or a suitable drainage system
- Do not install luminaires in sunken areas

Listings

- CE
- EAC pending
- RCM
- ENEC pending
- Compliant to EN 60598-2-13 A1 / A2 / A3 / A4 / A5 installation areas
- Made in Italy

Warranty

- 5-year limited warranty. Complete warranty terms located at www.performanceinlighting.com
- Registered trademark®

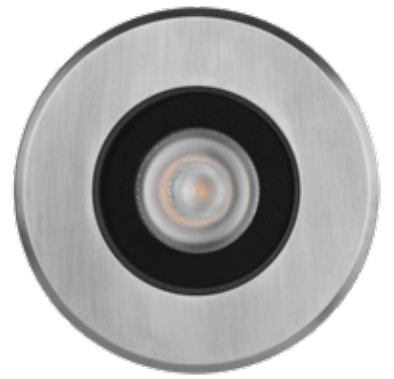

CRICKET+ 10
CRICKET+ 10 MARINE

CRICKET+ 15

CRICKET+ 20

CONSTRUCTION				
IP		IP67	IP67	IP67
IK		IK08 9J xx5	IK09 16J xx7	IK10 21J xx9
Dimensions (mm)		Ø 105 x H 82	Ø 190 x H 148	Ø 270 x H 145
Dimensions recessed box (mm)		Ø 158 x H 108	L 330 - H 170 - D 345	Ø 285 x H 350
Load torsion		max 2000 kg 5 kN 50 Nm	max 2000 kg 5 kN 50 Nm	max 2000 kg 5 kN 50 Nm
Weight		Max 0,71 kg	Max 2,90 kg	Max 4,85 kg
Colour		● ● ●	● ●	● ●
INSTALLATION				
Pre-wired		-	-	-
Quick		✓	✓	✓
Water Stop		✓	✓	✓
Continuous mounted luminaire		✓	✓	✓
LED				
Lightsource lumen output	3000 K	440 lm	1300 lm	2724 lm ÷ 2794 lm
	4000 K	475 lm	1403 lm	2940 lm
	rgbw 4000 K	-	-	1150 lm
Luminaire lumen output	3000 K	278 lm ÷ 415 lm	671 lm ÷ 1125 lm	1793 lm ÷ 2373 lm
	4000 K	278 lm ÷ 446 lm	717 lm ÷ 1203 lm	1916 lm ÷ 2536 lm
	rgbw 4000 K	-	-	538 lm
CCT - Correlated Color Temperature		3000 K - 4000 K	3000 K - 4000 K	rgbw 4000 K - 3000 K - 4000 K
CRI / SDCM (macadam step)		80/3	80/3	80/3
Lifetime		L90B10@94000h	L90B10@94000h	L80B10@50000h L90B10@94000h
OPTIC				
A5/M asymmetric medium reflector		-	A5/M	A5/M
C/EW extra wide circle reflector		C/EW	-	-
C/I intensive circle reflector		C/I	C/I	C/I
C/M medium circle reflector		C/M	C/M	C/M
ELECTRICAL				
Wattage		5 W	14 W	20 W - 26 W
Class		I	I	I - III
EEL		-	-	-
Ta MAX° luminaire		40°	50°	30° ÷ 35°
Ta MIN° luminaire		-20°	-20°	-40° ÷ -20°
Dimmable 1-10V		-	-	-
Dimmable DALI		-	-	✓
Emergency		-	-	-
COSφ ≥ 0,9		✓	✓	✓
STANDARDS				
UNI EN 60598-2-13		A1/A2/A3/A4/A5	A1/A2/A3/A4/A5	A1/A2/A3/A4/A5

- AN-96 / Anthracite gray / Textured
- INOX / Stainless steel / Matt
- BR-10 / Natural brass / Glossy



CRICKET+ 10 / 10 MARINE



High-transparency polycarbonate lenses grant an optimized light transmission

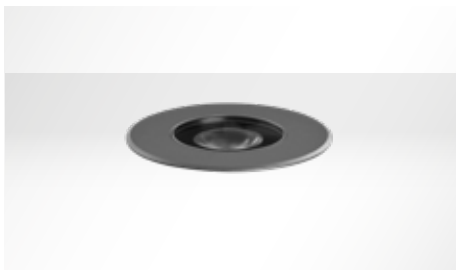

Die-cast aluminium trim painted



Closing ring in AISI 316 stainless steel with satin finish (stainless steel versions)



Closing ring in marine brass with polished finish



Mains connection device WATER STOP



Recessed housing manufactured from technopolymer. Order separately



The C/EW versions have a diffuser in flat, extra clear, tempered safety glass with acid-etched finish.

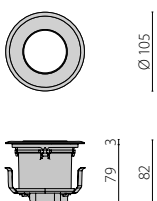

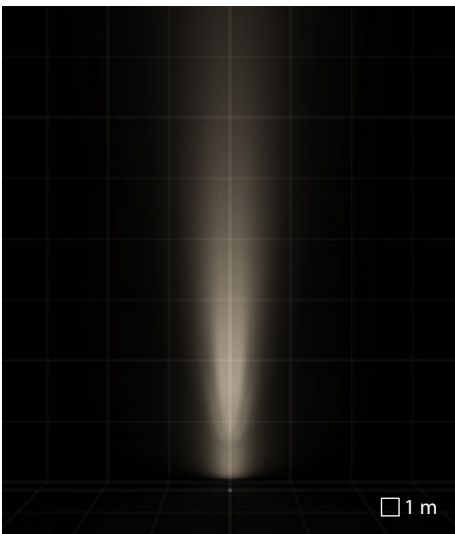

C/I intensive circle reflector

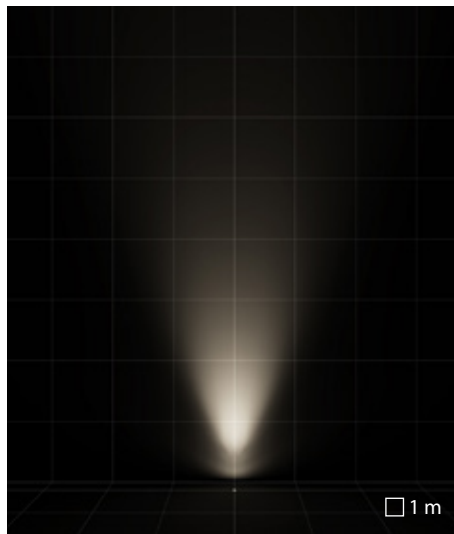

C/M medium circle reflector

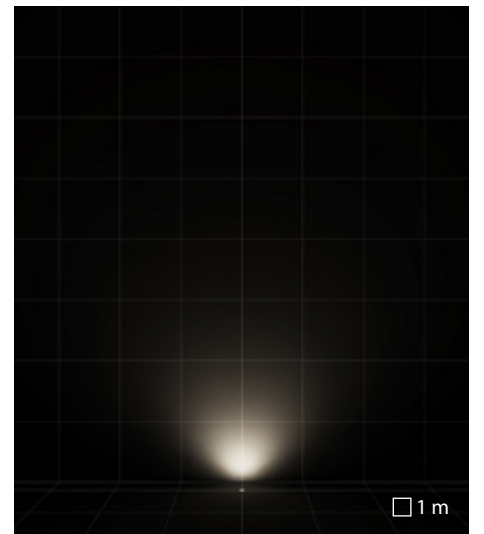

C/EW extra wide circle reflector

CRICKET+ 15



High-transparency polycarbonate lenses grant an optimized light transmission



Die-cast aluminium trim painted



Die-cast aluminium trim painted coated with AISI 316 stainless steel (versions INOX)



Mains connection device WATER STOP

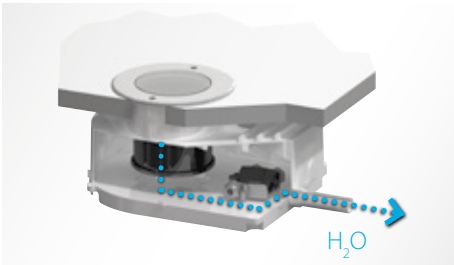

Technopolymer recessed casing available as an accessory to guarantee driveability and designed to favour water drainage through the WATER DRAIN system



RGBW (consult factory)



Tunable white (consult factory)

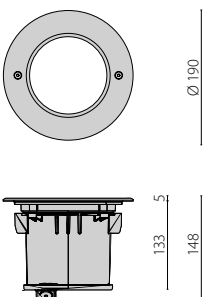



Residential and commercial complex | Parma | Italy

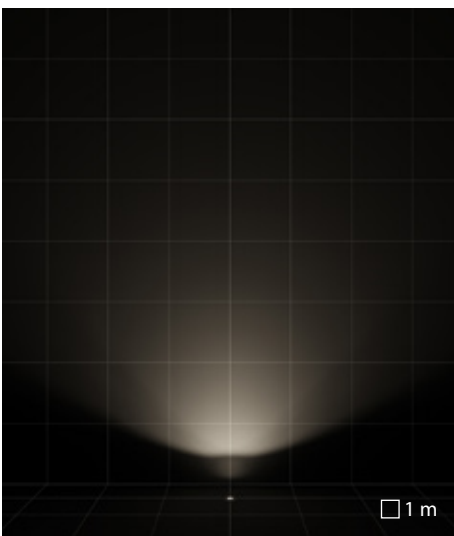

A5/M asymmetric medium reflector

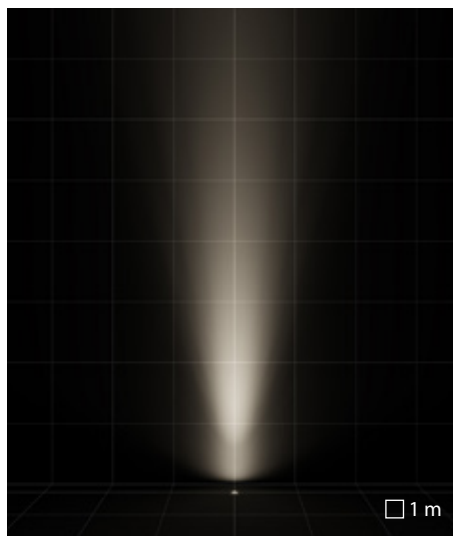

C/I intensive circle reflector

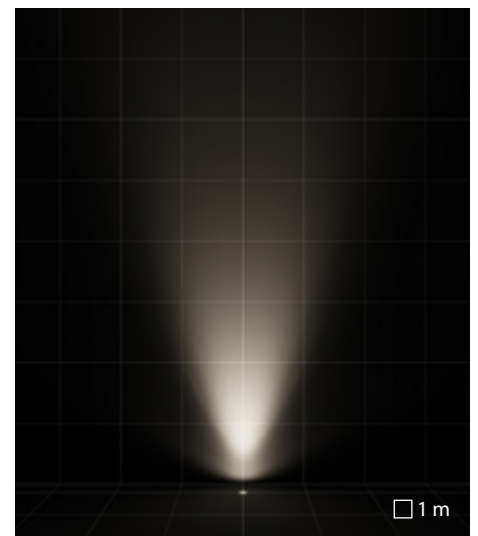

C/M medium circle reflector

CRICKET+ 20

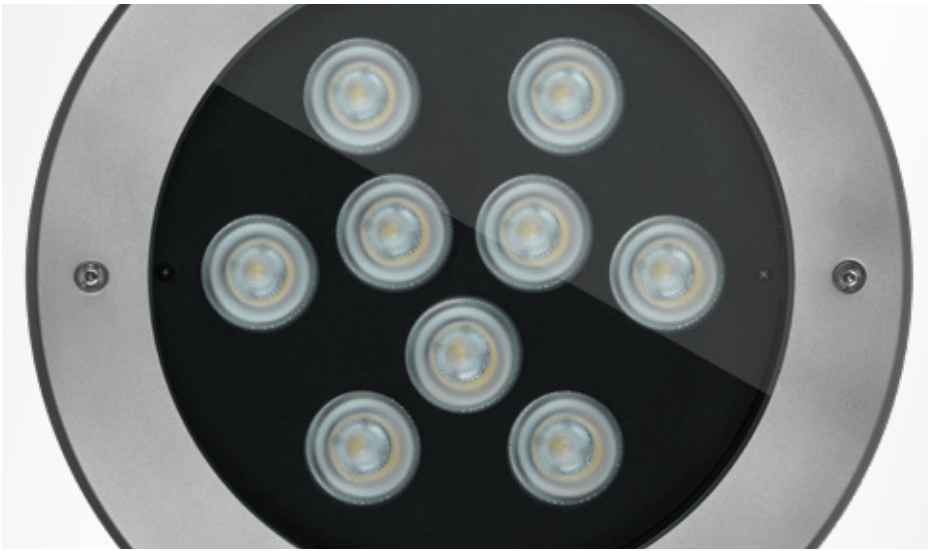

High-transparency polycarbonate lenses grant an optimized light transmission



Die-cast aluminium trim painted



Die-cast aluminium trim painted coated with AISI 316 stainless steel (versions INOX)



Mains connection device WATER STOP

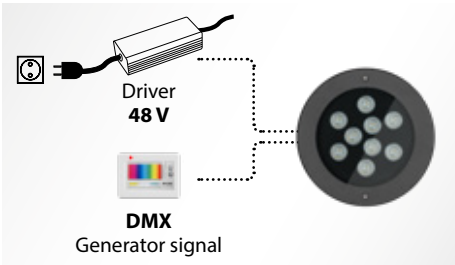

The RGBW versions should be powered at 48Vdc with SELV drivers, available as accessories. Colour management is through DMX interface.



RGBW



Tunable white (consult factory)

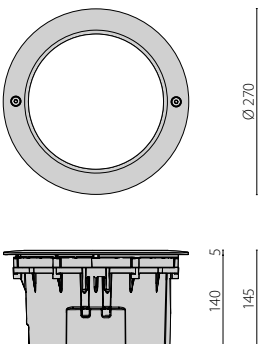



Hotel Don Carlos | Málaga | Spain

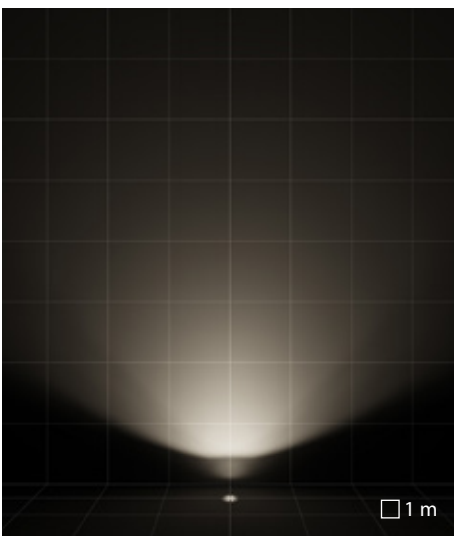

A5/M asymmetric medium reflector

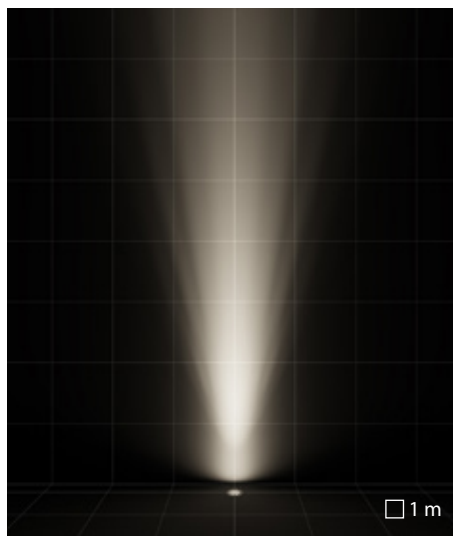

C/I intensive circle reflector

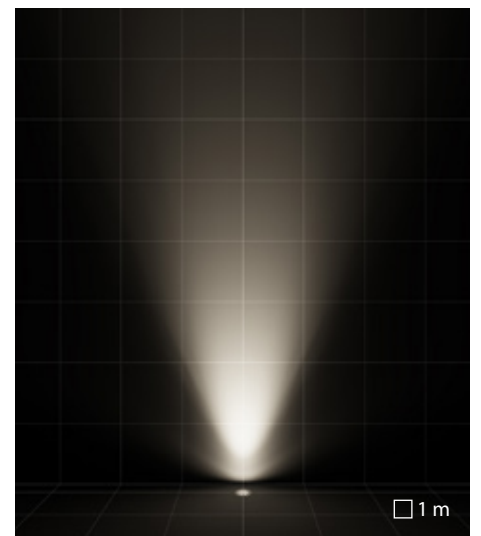

C/M medium circle reflector

STEEL SQUARE

Materials beyond standard

The formal language is simple and subordinated to the architecture: the luminaire is not the center of the scene; it is the light. Hence, the light becomes the leading actor in the tale of this series.

The STEEL series is designed for the diverse needs of inground drive-over luminaires. The precision-cast stainless steel trims are the elegant common element to all the configurations which characterize and make the individual product application unique. A bright, sleek and stylish feature in different shapes and sizes that enhances spaces, marks paths, illuminates architecture and exalts details, creating the right light in every context. The stainless steel that characterizes this series is a robust material resistant to any climate condition.

STEEL fixtures are available in a range of power levels and optics that enhance the potential and flexibility of the product. Thanks to the reduced depth recessed models, this series can be used with maximum freedom in every project.



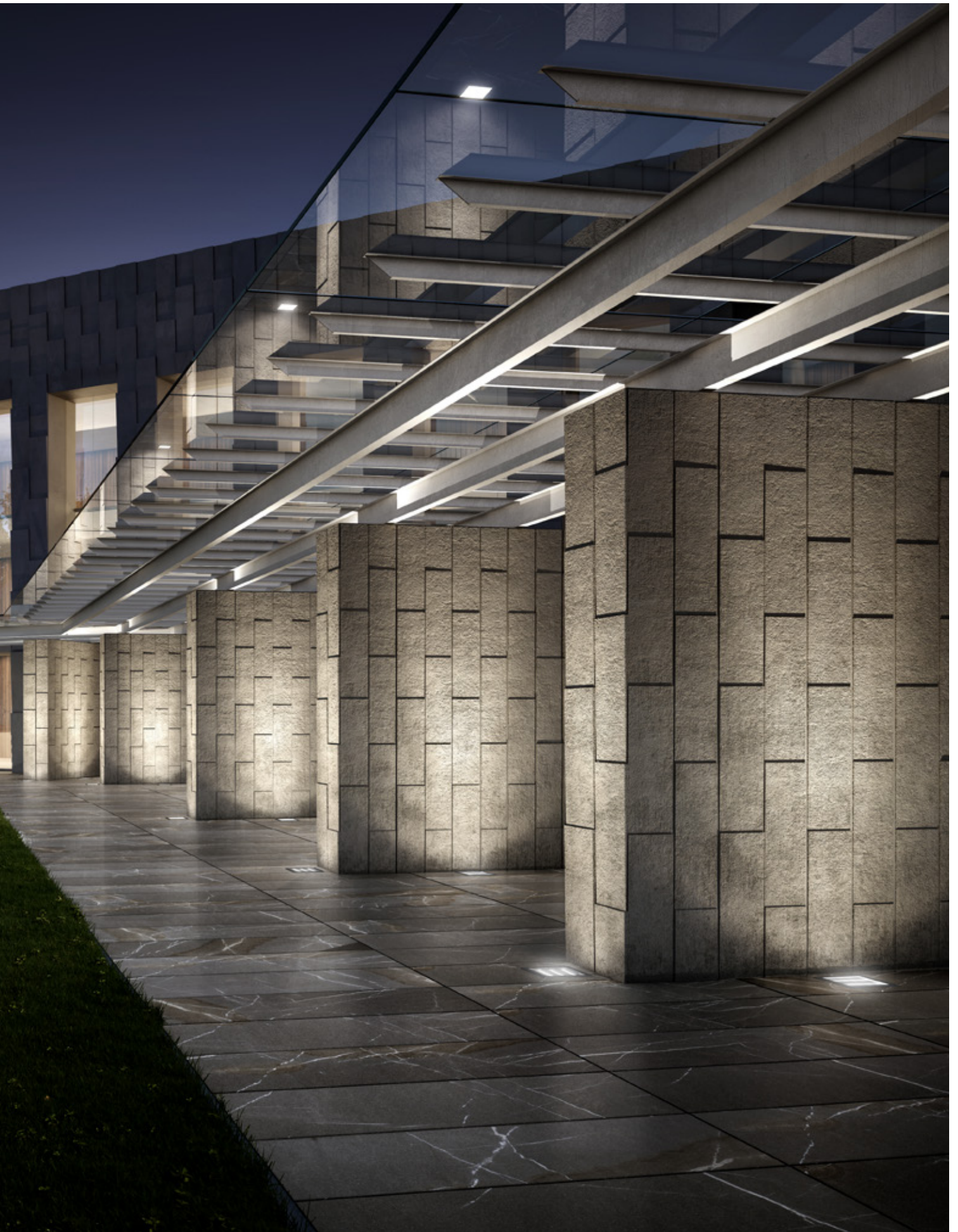

STEEL SQUARE

In-ground series. Fixtures consist of:

Construction

- Black painted anodised die-cast aluminium housing
- Powder polyester painting process optimised against UV rays in 13 different steps guaranteed ISO9227 against salt spray 1000 hours
- Precision-cast stainless steel trim
- Optic compartment separate from the power compartment for better heat control
- Anti-ageing silicone gasket
- Extra-clear tempered flat glass cover thickness 12 mm
- Stainless steel locking screws

Electrical

- Built-in driver

Installation

- LED extruded profiles may be oriented independently (+/- 10°)
- WATER STOP has been designed to avoid specific thermal and installation conditions, the humidity and condensation to be sucked up in the lighting body. Preserve the electrical components will provide definite and clear advantages for the security, the reliability, lifespan and look of the luminaires
- Recessed box to be ordered separately
- Technopolymer recessed box allows water drainage through the WATER DRAIN system. The recessed rough-in kit is also equipped with a removable cover, with two bubble levels inside for quick installation
- Each recessed box is delivered with a protective cover to avoid possible deformations during the installation in concrete and spirit level to ease the levelling during installation
- For outdoor applications, provide drainage gravel for at least 300 mm additional to the appliance or a suitable drainage system

Listings

- CE
- EAC
- RCM
- ENEC
- Compliant to EN 60598-2-13 A1 / A2 / A3 / A4 / A5 installation areas
- Made in Italy

Warranty

- 5-year limited warranty. Complete warranty terms located at www.performanceinlighting.com



STEEL SQUARE



STEEL SQUARE 20

STEEL SQUARE 28

STEEL SQUARE 34

	STEEL SQUARE 20	STEEL SQUARE 28	STEEL SQUARE 34
CONSTRUCTION			
IP	IP67	IP67	IP67
IK	IK10 20J xx9	IK10 20J xx9	IK10 20J xx9
Dimensions (mm)	L 200 x H 119 x D 200	L 280 x H 119 x D 280	L 340 x H 119 x D 340
Dimensions recessed fixing box (mm)	L 334 x H 127 x D 347	L 384 x H 127 x D 397	L 454 x H 127 x D 467
load torsion	max 2200 kg 5 kN 50 Nm	max 2800 kg 5 kN 50 Nm	max 2200 kg 5 kN 50 Nm
Weight	max 3,44 kg	max 6,01 kg	max 8.55 kg
Colour	●	●	●
INSTALLATION			
Pre-wired	-	-	-
Quick	✓	✓	✓
Water Stop	✓	✓	✓
Continuous mounted luminaire	✓	✓	✓
LED			
Lightsource lumen output 3000 K	510 lm	1530 lm	2040 lm
Luminaire lumen output 3000 K	278 lm ÷ 346 lm	852 lm ÷ 1056 lm	1087 lm ÷ 1357 lm
CCT - Correlated Color Temperature	3000 K	3000 K	3000 K
CRI / SDCM (macadam step)	80/3	80/3	80/3
Lifetime	L80B10@50000h	L80B10@50000h	L80B10@50000h
OPTIC			
C/I intensive circle reflector	C/I 8°	C/I 8°	C/I 8°
ELL elliptical reflector	ELL 10°x45°	ELL 10°x45°	ELL 10°x45°
ELECTRICAL			
Wattage	6,6 W	20 W	26 W
Class	I	I	I
EEL	A2÷A3	A2÷A3	A2÷A3
Ta MAX°C luminaire	45°C	40°C ÷ 50°C	40°C ÷ 50°C
Ta MIN°C luminaire	-10°C	-20°C ÷ -10°C	-20°C ÷ -10°C
Dimmable 1-10 V	-	-	-
Dimmable DALI	-	-	-
Emergency	-	-	-
COSφ ≥ 0,9	✓	✓	✓
STANDARDS			
UNI EN 60598-2-13	A1 - A2 - A3 - A4 - A5	A1 - A2 - A3 - A4 - A5	A1 - A2 - A3 - A4 - A5

● INOX / Stainless steel / Glossy



Burg Landshut | Bernkastel-Kues | Germany

STEEL SQUARE

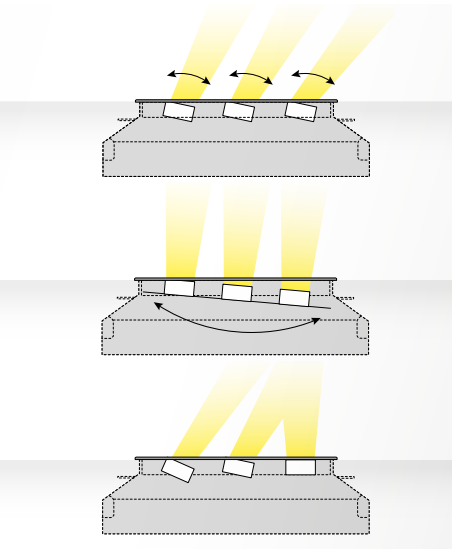

In all STEEL SQUARE models, the LEDs are positioned on adjustable bars that allow the light to be directed, concentrating as necessary. The bars must be adjusted before mounting the glass and the closing ring.

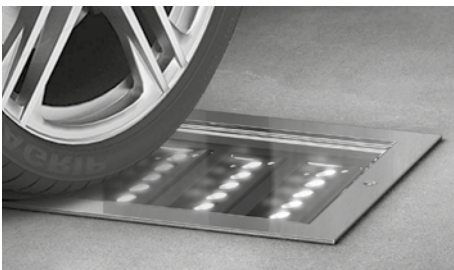

Drive-over luminaire.



Precision-cast stainless steel trim.

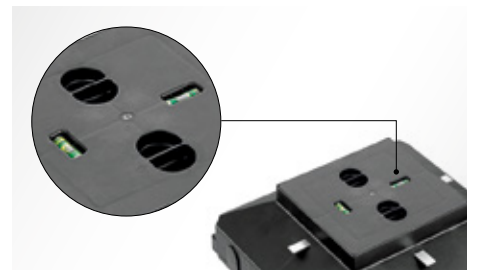

All STEEL SQUARE recessed fixing kits are equipped with a cover with a spirit level to facilitate correct position during installation.



The COMPACT shape provides the perfect solution for installation into shallow depths, providing drainage by means of the specially developed shape of the outer housing to an outflow pipe.

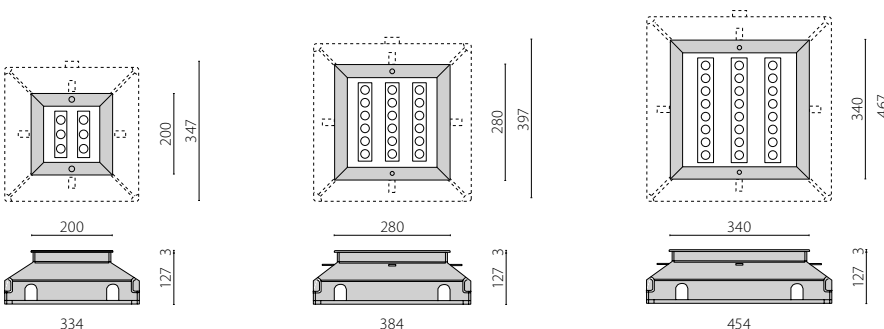



Charter square | Raleigh - North Carolina | USA

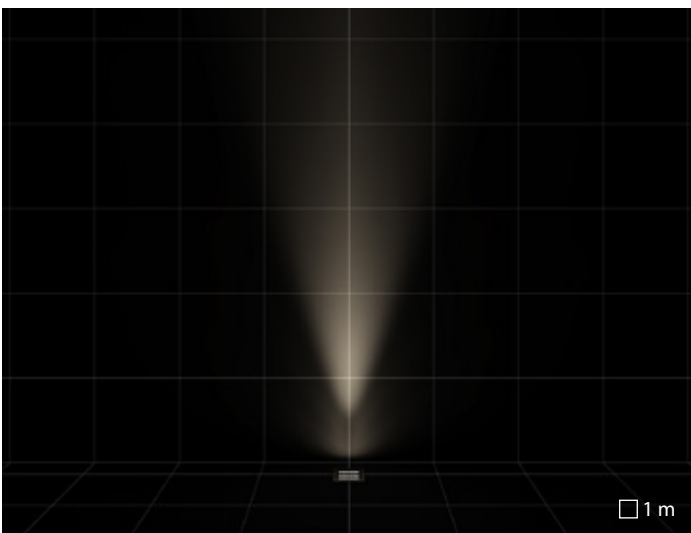

C/I intensive circle reflector

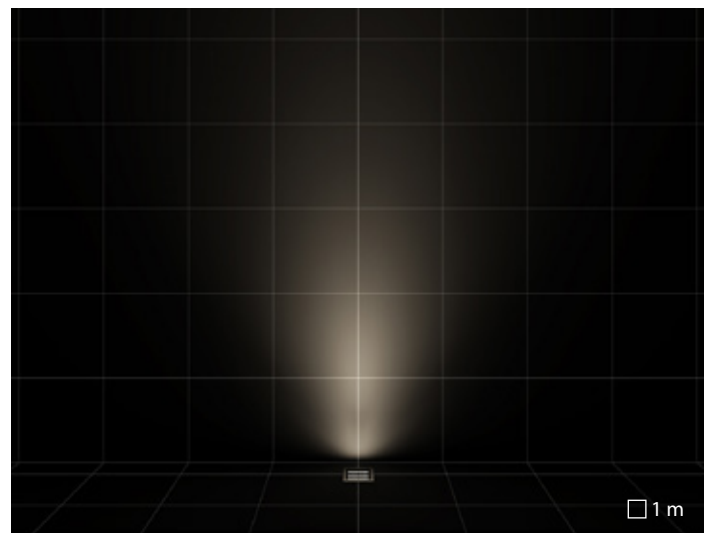

ELL elliptical reflector

EN 60598-2-13

INSTALLATION AREA UNREACHABLE TO PEOPLE AND VEHICLES

The relevant European standard EN 60598-2-13 defines the suitable areas for installation of ground recessed luminaires based on static load, ledge from the ground of the diffuser and the temperature of the diffuser itself. These characteristics establish whether the luminaire is suitable for specific situations (vehicle transit, pedestrian crossing, playgrounds, etc.). To make luminaire selection easier for each product, the pages below show the code of the areas where the installation is permitted, based on the standard and the technical characteristics.



Castle | Saint Sauveur Le Vicomte | FRANCE

A1 - NO-TOUCH AREA (kN, mm, °C not applied)

Installation area inaccessible to people and vehicles



Corte del vicariato | Monteforte | ITALY

A2 - WALK-OVER AREA (≥ 5 kN, ≤ 5 mm / ≤ 25 mm, ≤ 100 °C)

Installation area with limited access, for example areas for pedestrians only, cyclists only, etc., in no-passing areas, e.g. near to walls, buildings, etc.

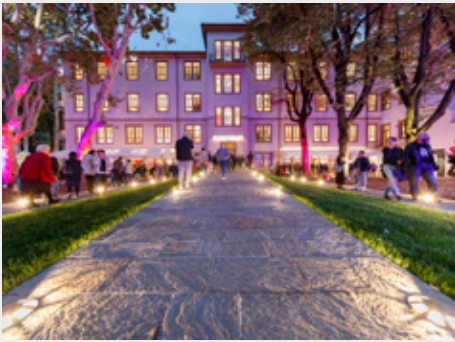

Casa emergency | Milan | ITALY



Charter square | Raleigh - North Carolina | USA



Kairos headquarters | Verona | ITALY

A3 - MOTORABLE AREA
(≥ 20 kN, ≤ 75 mm /, $\leq 80^\circ$ C)

Installation area with limited access, for example areas for pedestrians only, cyclists only, etc.

A4 - MOTORABLE AREA PLUS
(≥ 20 kN, ≤ 5 mm / ≤ 25 mm, $\leq 80^\circ$ C)

Installation area accessible to snowplough vehicles or where anti-freeze agents are used, for example, near to walls, buildings, etc. in no-passing areas, e.g. near to walls, buildings, etc.

A5 - TOUCH WALK-OVER AREA
(≥ 5 kN, ≤ 5 mm / ≤ 25 mm, $\leq 40^\circ$ C)

For example children's areas, swimming pools, in no-passing areas, e.g. near to walls, buildings, etc. where temperatures can cause wounds.



VERTICAL SURFACES

The grazing and wall washer light collection



A vertical surface means sometimes limit, margin, barrier if placed laterally or on the perimeters of an area and may give a marked direction to space. But it already may represent a unifying element placed in the space. "A vertical surface may be defined as the meeting of two fundamental dimensions of human life: the terrestrial dimension and the aerial dimension (Italo Calvino)". Vertical surfaces are the visible expression of the tension between these two dimensions in fact, "Cities also think to be the work of the mind or the chance, but neither the one nor the other are enough to keep their walls upright. You do not enjoy the seven or seventy-seven marvels of a city, but the

answer it provides to your question (Marco Polo)". These two dimensions, together with depth, create shadows, rhythms and elements that provide strength and identity to a facade. In this context, the clever use of lighting techniques plays a strategic role. Wall-washing will mainly contribute to the feeling of the luminosity of the locations and is usually used on smooth surfaces. Grazing lighting, instead, will be used to enhance their texture and materiality; both will instil a feeling of security.

STRIP SQUARE+

design Roberto Fiorato

The wall grazer family

Designed around the same low profile, our newly redesigned STRIP SQUARE+ is now upgraded to include various options to meet a wide variety of application needs. This workhorse now offers additional choices such as RGBW, Dynamic Tunable White, and multiple optics.

Whether you're looking to illuminate your building by incorporating our surface mount version with its adjustable arm or use the in-ground, drive over version, this minimalistic design will integrate well into almost any space and highlight your architectural area. The quick-connect component makes installation a contractor's dream while maintaining watertight integrity and eliminating the need to open the fixture during installation.





STRIP SQUARE+

design Roberto Fiorato

Linear surface mount (STRIP SQUARE+) and linear in-ground (STRIP SQUARE+ INGROUND) series.
Fixtures consist of:

Construction

- Extruded anodised aluminium housing
- Die-cast aluminium end caps, painted
- Aluminium gear tray for high heat dissipation of components
- Anti-ageing silicone gasket
- Tempered glass diffuser, screen-printed inside
- Stainless steel locking screws

Electrical

- Built-in driver
- Available with ON-OFF driver and dimmable DALI
- TW - TUNABLE WHITE(2700 ÷ 6500 K) version DALI DT8

Installation

- Adjustable wall mounting bracket with joint for directing the luminaire
- External electrical connection with IP-rated QUICK connector, complete with cable
- Recessed box to be ordered separately
- Each recessed box is delivered with a protective cover to avoid possible deformations during the installation in concrete and spirit level to ease the levelling during installation
- For outdoor applications, provide drainage gravel for at least 300 mm additional to the appliance or a suitable drainage system
- DMX signal generator for RGBW versions to be ordered separately

Listings

- CE
- EAC
- RCM
- Compliant to EN 60598-2-13 A1 / A2 / A3 / A4 / A5 installation areas
- Made in Italy

Warranty

- 5-year limited warranty. Complete warranty terms located at www.performanceinlighting.com



STRIP SQUARE+



	STRIP SQUARE+	STRIP SQUARE+ INGROUND	
CONSTRUCTION			
IP	IP66	IP67	
IK	IK10 20J xx9	IK10 20J xx9	
Dimensions (mm)	L 528 - 780 - 1032 - 1284 x H 71 x D 139	L 550 - 802 - 1054 - 1306 x H 72 x D 100	
Dimensions recessed box (mm)	-	L 590 - 842 - 1094 - 1346 x H 122 x D 130	
Load torsion	-	max 2000 kg 5 kN 50 Nm	
Weight	Max 7,19 kg	Max 8,74 kg	
Colour	●	●	
INSTALLATION			
Pre-wired	✓	✓	
Quick	-	✓	
Water Stop	✓	✓	
Continuous mounted luminaire	-	✓	
LED			
Lightsource lumen output	tw 2700 - 6500 K	864 lm ÷ 2160 lm	864 lm ÷ 2160 lm
	3000 K	2000 lm ÷ 5000 lm	2000 lm ÷ 5000 lm
	4000 K	2130 lm ÷ 5400 lm	2130 lm ÷ 5400 lm
	rgbw 2700 K	1456 lm ÷ 3209 lm	1456 lm ÷ 3209 lm
Luminaire lumen output	tw 2700 - 6500 K	735 lm ÷ 1868 lm	735 lm ÷ 1868 lm
	3000 K	1374 lm ÷ 3447 lm	1374 lm ÷ 3447 lm
	4000 K	1467 lm ÷ 3681 lm	1467 lm ÷ 3681 lm
	rgbw 2700 K	855 lm ÷ 1965 lm	855 lm ÷ 1965 lm
CCT - Correlated Color Temperature	rgbw 2700 K - tw 2700 - 6500 K 3000 K - 4000 K	rgbw 2700 K - tw 2700 - 6500 K 3000 K - 4000 K	
CRI / SDCM (macadam step)	80/3	80/3	
Lifetime	L80B10@60000h	L80B10@60000h	
OPTIC			
S/I symmetric narrow reflector	S/I	S/I	
A18/M asymmetric medium reflector	A18/M	A18/M	
ELL 15°x45° elliptical reflector	ELL 15°x45°	ELL 15°x45°	
ELL 40°x60° elliptical reflector	ELL 40°x60°	ELL 40°x60°	
ELECTRICAL			
Wattage	14 W - 15 W - 16 W - 21 W - 22 W - 26 W 27 W - 28 W - 32 W - 33 W - 35 W - 20.5 W	14 W - 15 W - 16 W - 21 W - 22 W - 26 W 27 W - 28 W - 32 W - 33 W - 35 W - 20.5 W	
Class	II - III	I - III	
EEL	-	-	
Ta MAX° luminarie	40° ÷ 35°	45° ÷ 35°	
Ta MIN° luminarie	-10° ÷ -25°	-10° ÷ -25°	
Dimmable 1-10V	-	-	
Dimmable DALI	✓	✓	
Emergency	-	-	
COSφ ≥ 0,9	✓	✓	
CONTROL SYSTEMS			
Tunable White	✓	✓	
STANDARDS			
UNI EN 60598-2-13		A1/A2/A3/A4/A5	

● GR-11 / Anodised grey / Matt



Casa Bau | Tortosa | Spain

STRIP SQUARE+



Adjustable wall mounting bracket with joint for directing the luminaire.

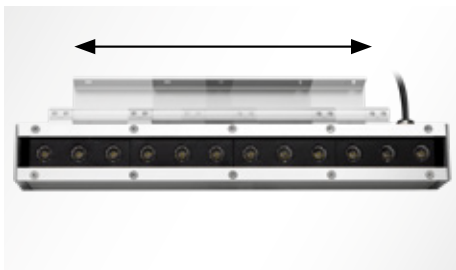

Wall mounting bracket adjustable all along the fitting body.



On request, a precabled version with double watertight cable clamp and cable for cascade connections can be supplied.



Adjustable tilt up to 15°. Double securing grain.

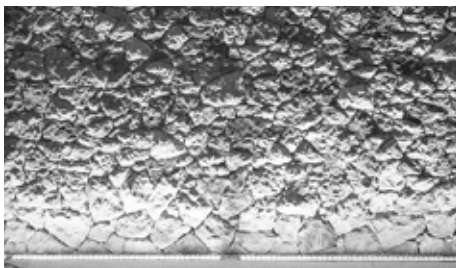

Suitable for wall grazing effects.



RGBW

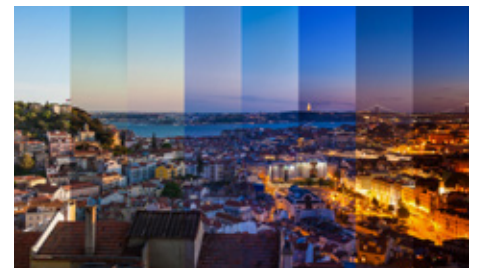

Tunable white

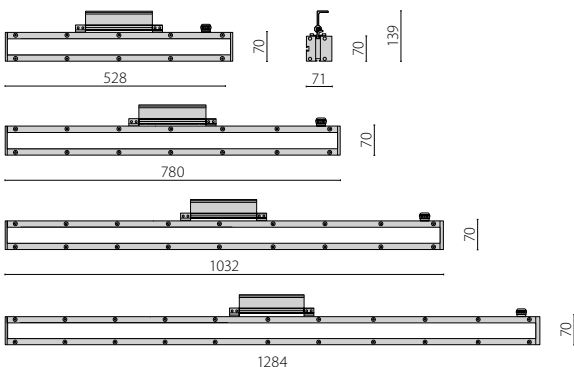

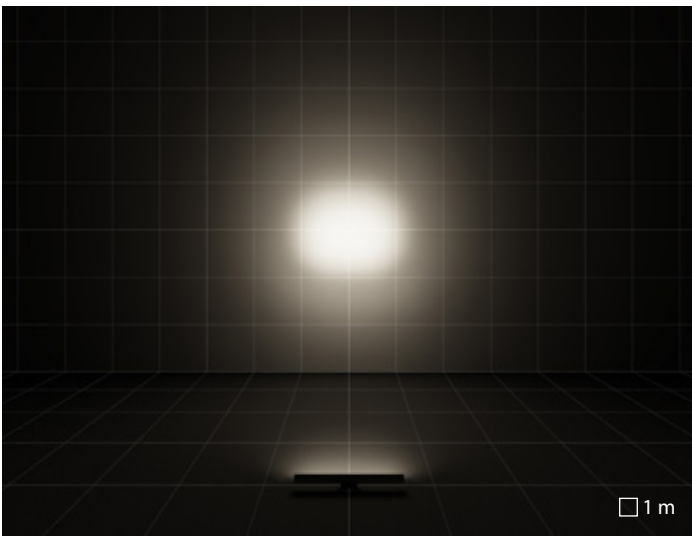

S/1 symmetric narrow reflector

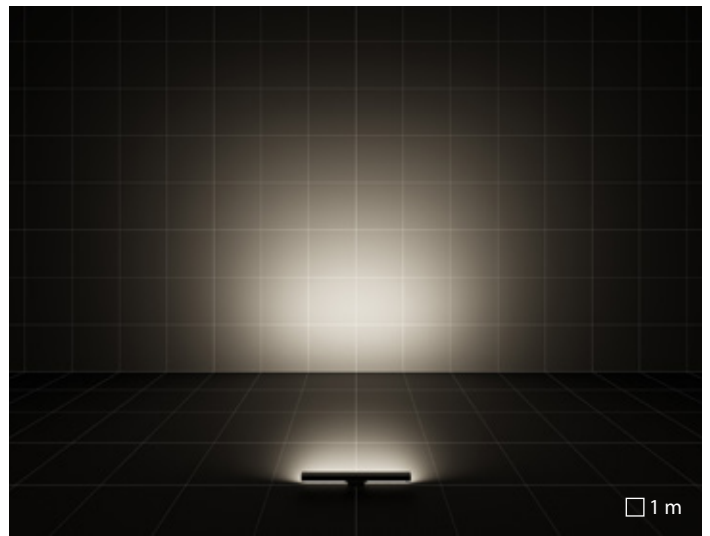

A18/M asymmetric medium reflector

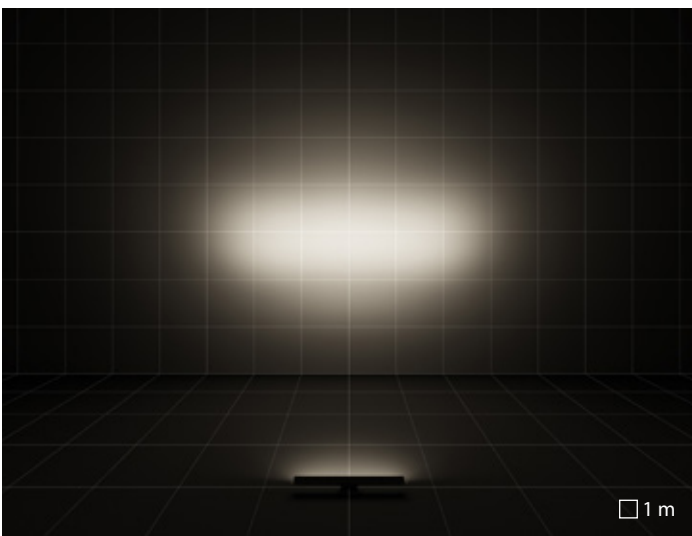

ELL 15°x45° elliptical reflector

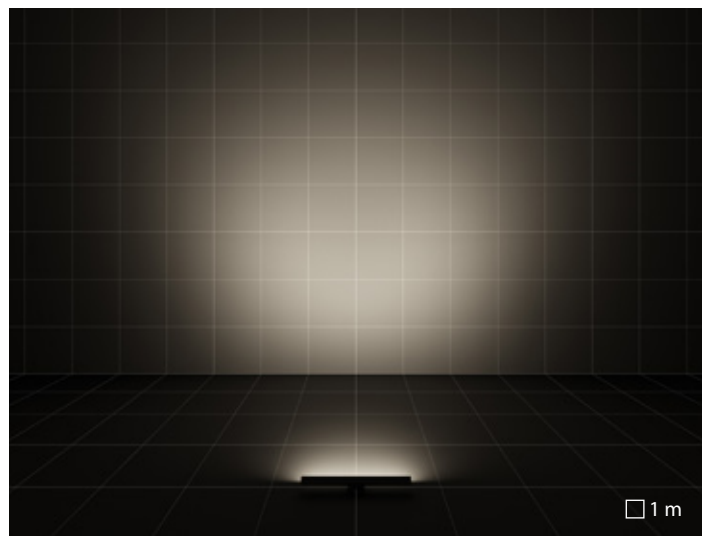

ELL 40°x60° elliptical reflector

STRIP SQUARE+

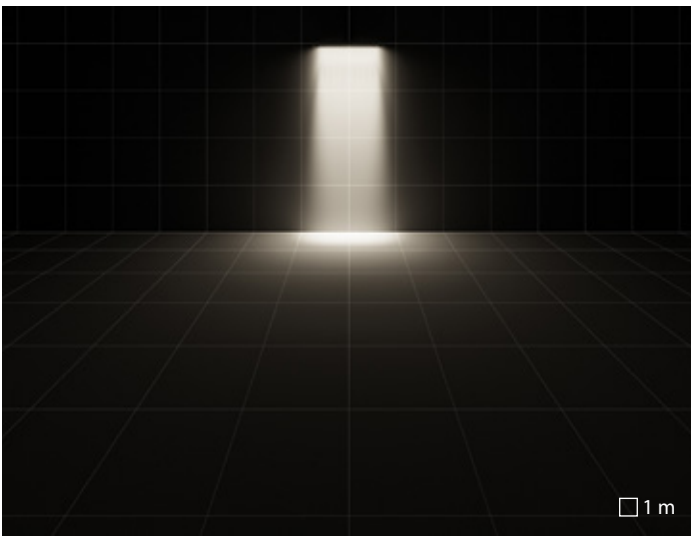

S/I symmetric narrow reflector

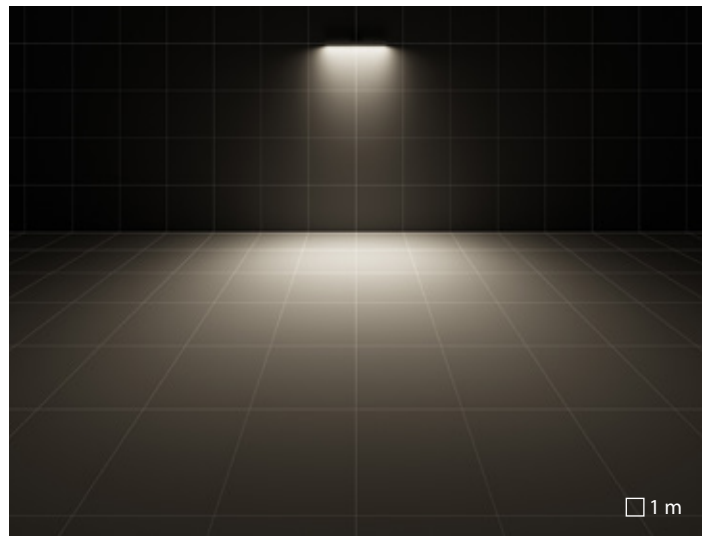

A18/M asymmetric medium reflector

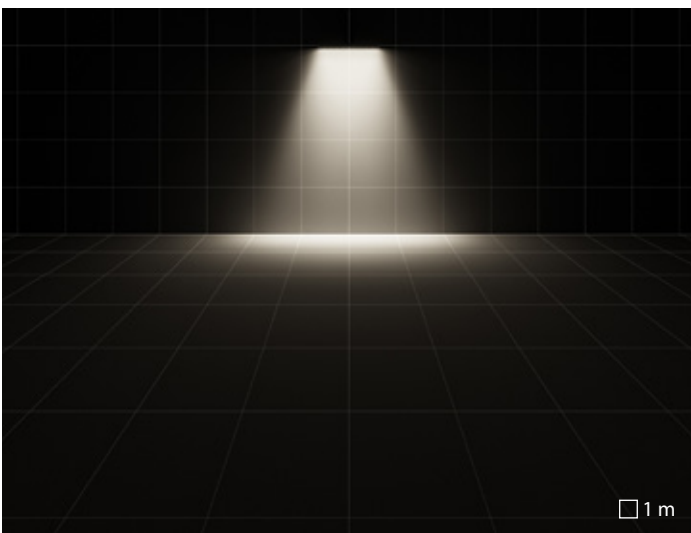

ELL 15°x45° elliptical reflector

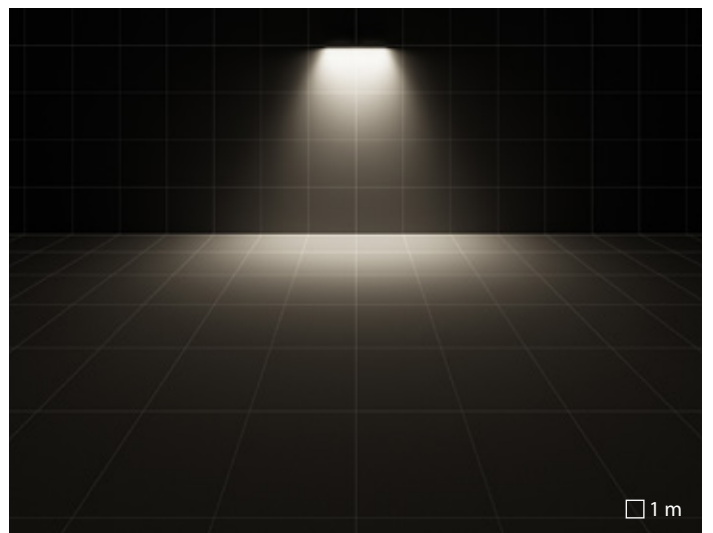

ELL 40°x60° elliptical reflector

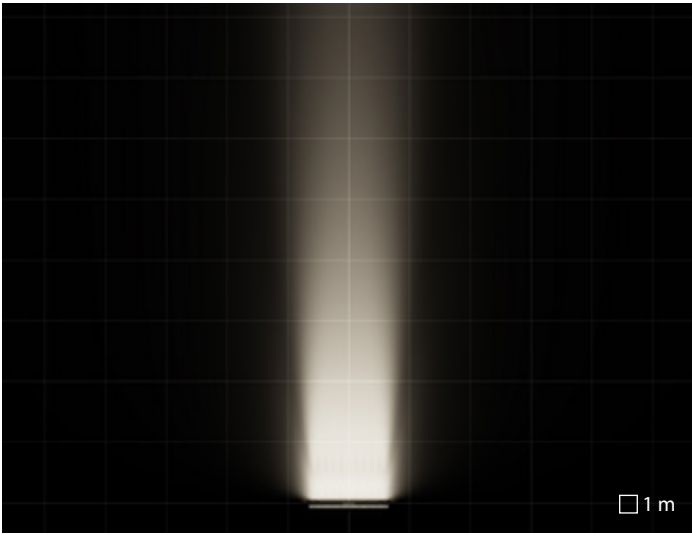

S/1 symmetric narrow reflector

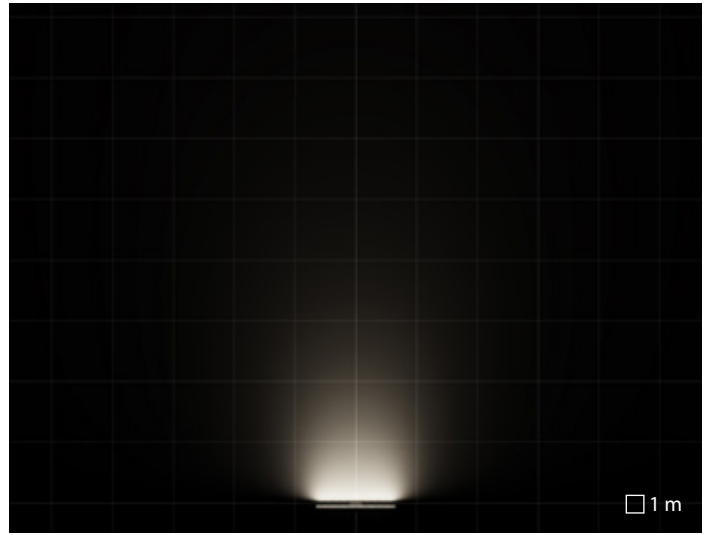

A18/M asymmetric medium reflector

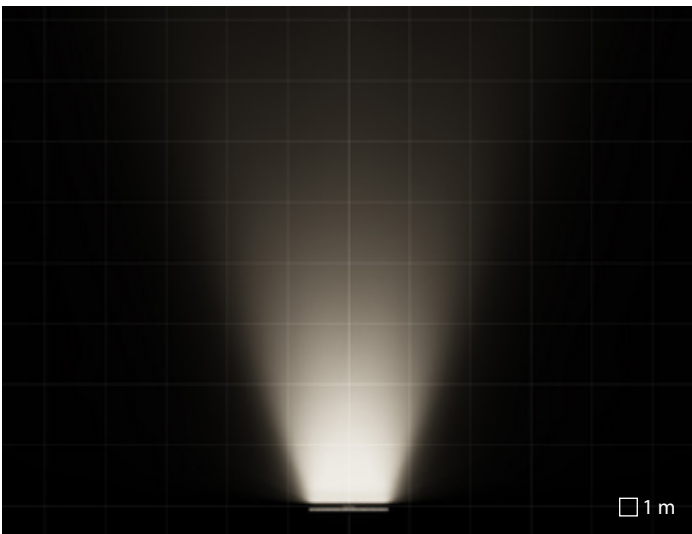

ELL 15°x45° elliptical reflector

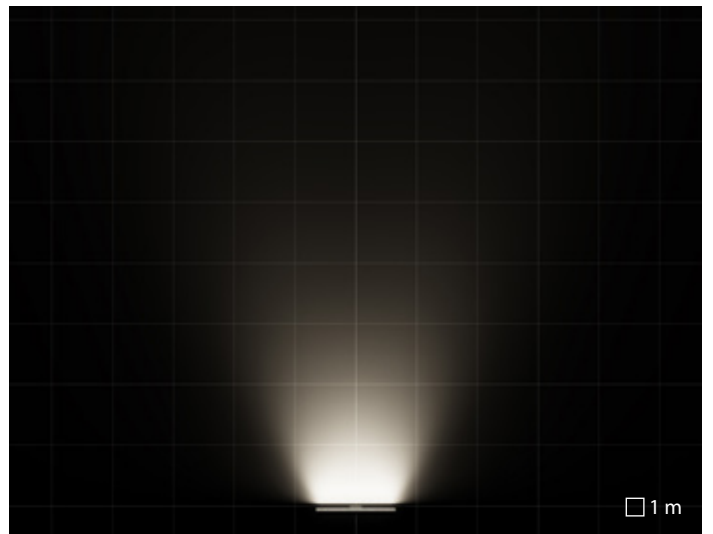

ELL 40°x60° elliptical reflector





Verbindingstunnel van heekgarage | Enschede | Netherlands

STRIP SQUARE+ INGROUND



Drive-over luminaire.



Tear-proof cable.

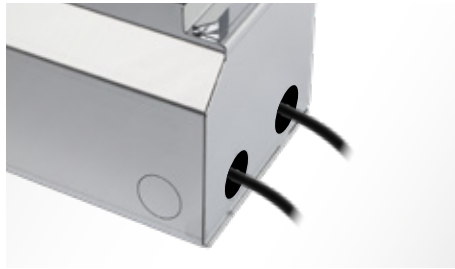

Designed for cable outlets.



Cool touch.



Every recessed fixing kit is fitted with a protective cover to avoid any deformations during phases of installation in cement.



A full, complete luminaire is the ensemble of lighting fixture + rough-in kit.

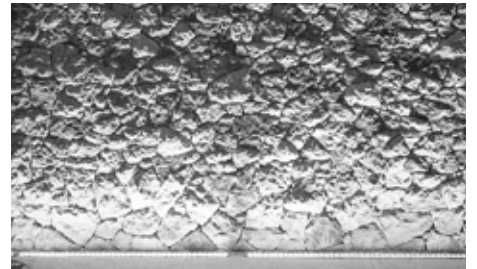

Suitable for wall grazing effects.

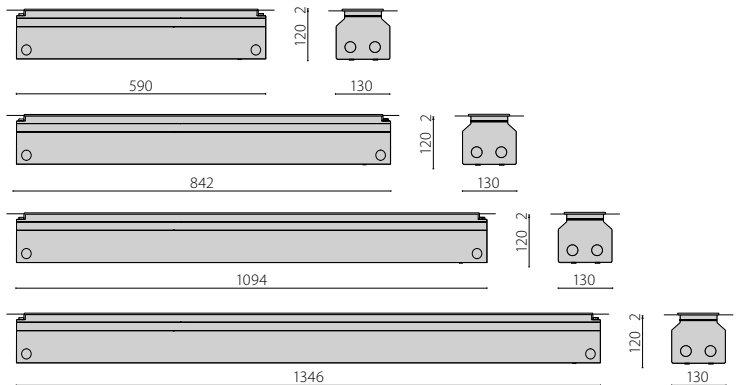
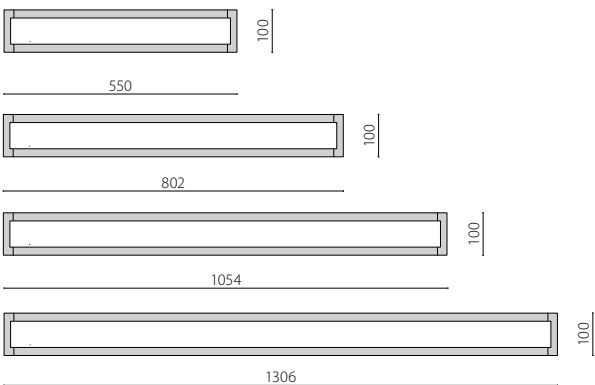

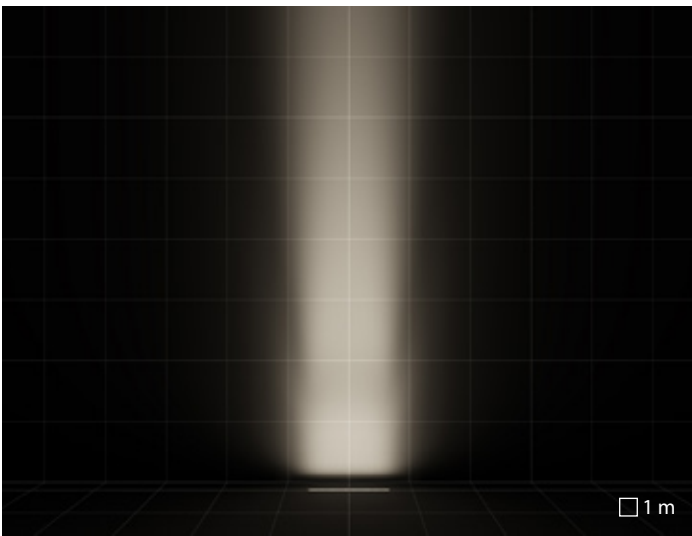

S/I symmetric narrow reflector

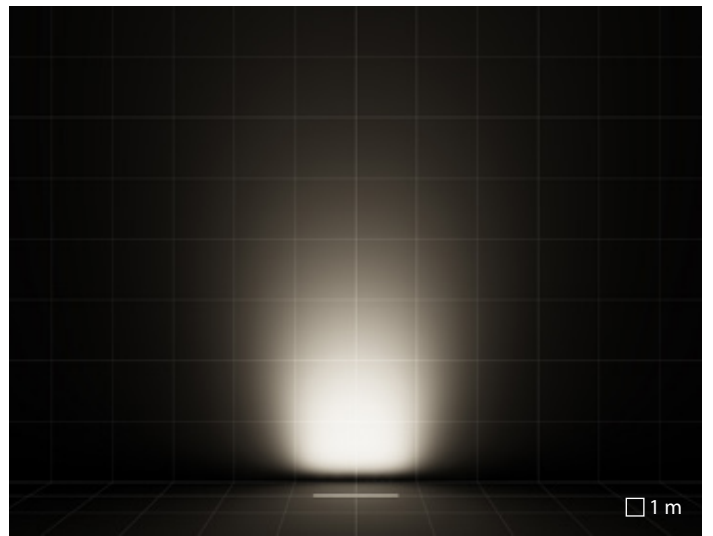

A18/M asymmetric medium reflector

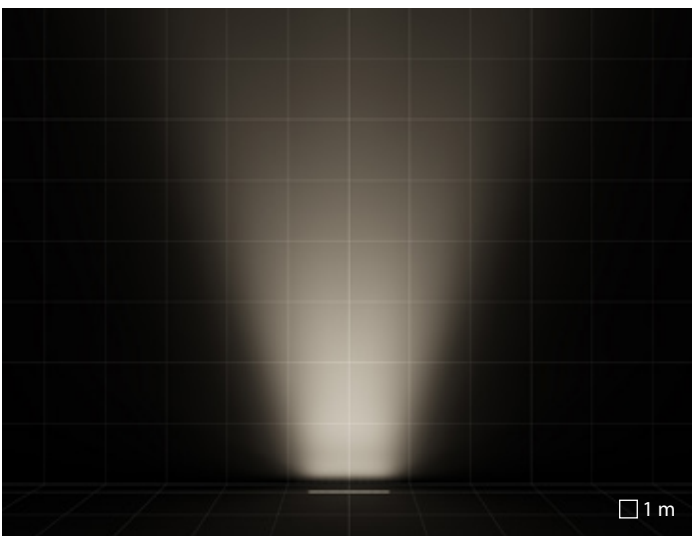

ELL 15°x45° elliptical reflector

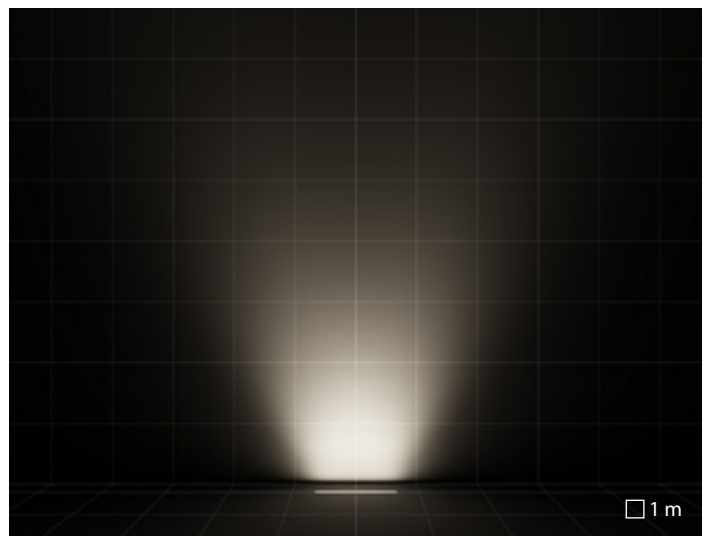

ELL 40°x60° elliptical reflector

NOTTURNO

Enhancing Architecture

NOTTURNO is an innovative, modular wall mount fixture series engineered for grazing, wall washing and accent lighting. Its compact size and versatility can be utilized to illuminate from extremely tight spaces up to very large facades.

No scalloping when installing in rows. With only 5 mm minimum distance requirement between each fixture, the output is uniform seeming as if one fixture not several.

This kind of lighting creates a light and shadow game that emphasizes the three-dimensionality of the surface material, such as stone, bricks, or texture.

NOTTURNO's finely machine-crafted body is perfection; no sealants or gaskets, yet IP66 wet location rating. With a wide range of optics, telescoping wall brackets, and a beautifully designed triangular shape, NOTTURNO is the right choice for just about any façade lighting project.





Casa Museo Maffei | Verona | Italy

NOTTURNO

Linear surface mount series. Fixtures consist of:

Construction

- Extruded anodised aluminium housing
- Stainless steel AISI 304 end caps
- Aluminium heat sink
- Tempered glass diffuser, screen-printed inside

Electrical

- Available with ON-OFF driver and dimmable DALI

Installation

- For product installation, please select the appropriate bracket (available as mandatory accessory)

Listings

- CE
- EAC
- RCM
- Made in Italy

Warranty

- 5-year limited warranty. Complete warranty terms located at www.performanceinlighting.com
- Registered trademark®



NOTTURNO

		NOTTURNO 500	NOTTURNO 1000	NOTTURNO 1500
CONSTRUCTION				
IP		IP66	IP66	IP66
IK		IK07 2J xx5	IK07 2J xx5	IK07 2J xx5
Dimensions (mm)		L 504 x H 60 x D 52	L 972 x H 60 x D 52	L 1440 x H 60 x D 52
Weight		max 2,03 kg	max 3,71 kg	max 5,37 kg
Colour		●	●	●
INSTALLATION				
Pre-wired		-	-	-
Quick		✓	✓	✓
Water Stop		-	-	-
Continuous mounted luminaire		-	-	-
LED				
Lightsource lumen output	3000 K	2016 lm	4032 lm	6064 lm
	4000 K	2016 lm	4032 lm	6064 lm
Luminaire lumen output	3000 K	1606 lm ÷ 1623 lm	3088 lm ÷ 3122 lm	4571 lm ÷ 4621 lm
	4000 K	1606 lm ÷ 1623 lm	3088 lm ÷ 3122 lm	4571 lm ÷ 4621 lm
CCT - Correlated Color Temperature		3000 K - 4000 K	3000 K - 4000 K	3000 K - 4000 K
CRI / SDCM (macadam step)		80/3	80/3	80/3
Lifetime		L80B10@60000h	L80B10@60000h	L80B10@60000h
OPTIC				
S/I symmetric narrow reflector		S/I 12°	S/I 12°	S/I 12°
S/M symmetric medium reflector		S/M 30°	S/M 30°	S/M 30°
ELL elliptical reflector		ELL 13°x36°	ELL 13°x36°	ELL 13°x36°
ELECTRICAL				
Wattage		20 W	38 W	54 W
Class		III	III	III
EEL		-	-	-
Ta MAX°C luminaire		50°C	50°C	50°C
Ta MIN°C luminaire		-30°C	-30°C	-30°C
Dimmable 1-10 V		-	-	-
Dimmable DALI		-	-	-
Emergency		-	-	-
COSφ ≥ 0,9		✓	✓	✓

● GR-11 / Anodised grey / Matt



Church of St. George in Braida | Verona | Italy

NOTTURNO

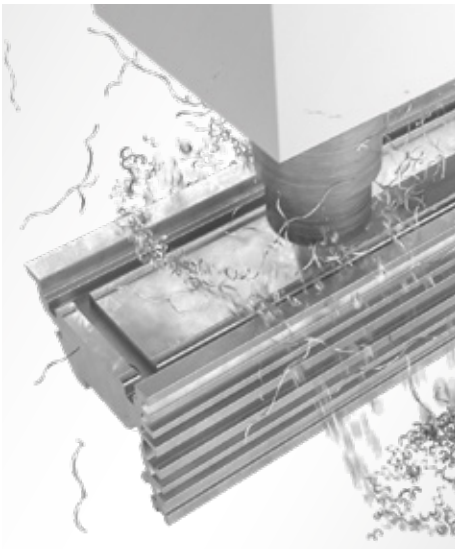

Solid aluminium alloy extruded and machine-crafted to achieve a perfect watertight housing for PCBs and LEDs.



The profile is waterproof without side terminals: no gasket, screws.



Adjustable wall bracket in stainless steel.



Adjustable floor bracket in stainless steel.



Adjustable telescopic bracket in stainless steel.



Adjustable supports for indoor mounting in stainless steel.



Triangular shape, ultracompact size.



Single mounting or linear compositions with a minimum distance between modules of 5mm.

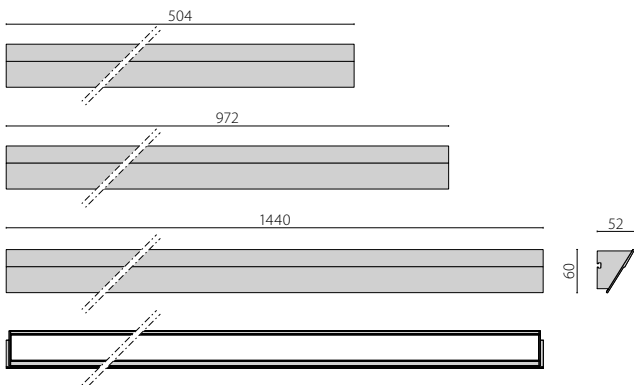

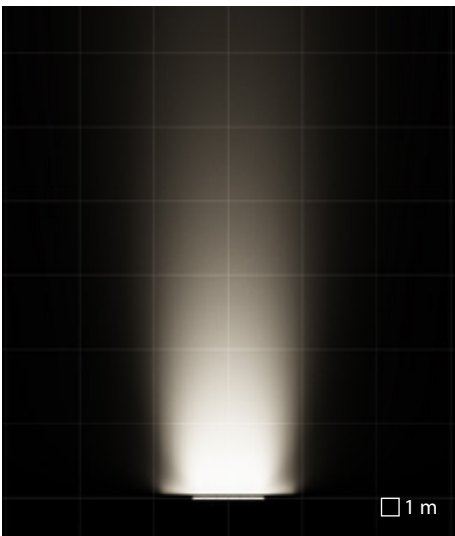

S/I symmetric narrow reflector

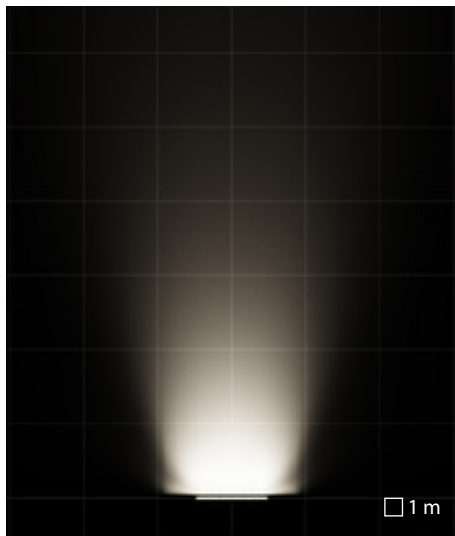

S/M symmetric medium reflector

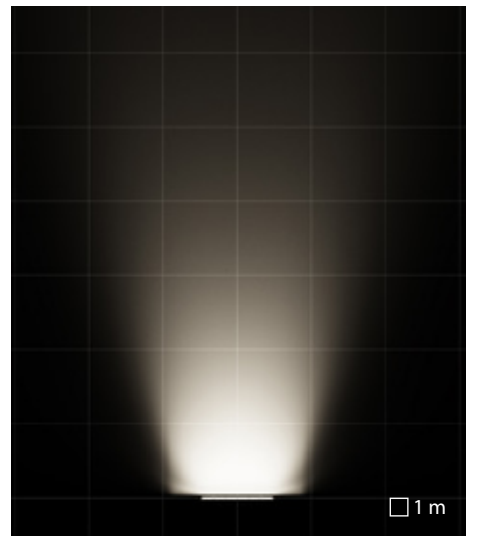

ELL elliptical reflector

OMBRA

No shadows, only light

OMBRA offers an outdoor rated linear accent light with superior optical performance and efficiency in very a small-scale profile. This product family provides even illumination adding depth and enhanced visual comfort. The telescoping bracket and adjustability allows positioning and aiming precisely to meet project requirements. OMBRA is installation and maintenance friendly.

Imagine installing lengths up to 50 m using one feed point and being able to replace integral driver without having to remove end caps and gaskets which may allow water intrusion and humidity. OMBRA is aesthetically pleasing making it the right choice for the designer and at the same time provides easy maintenance accessibility making it the perfect option for the installer.





OMBRA

Linear surface mount series. Fixtures consist of:

Construction

- Extruded anodised aluminium housing
- Stainless steel AISI 304 end caps
- Aluminium heat sink
- Anti-ageing silicone gasket
- Tempered glass diffuser, screen-printed inside
- Stainless steel locking screws

Electrical

- Built-in driver
- Available with ON-OFF driver and dimmable DALI

Installation

- For product installation, please select the appropriate bracket (available as mandatory accessory)

Listings

- CE
- EAC
- RCM
- Made in Italy

Warranty

- 5-year limited warranty. Complete warranty terms located at www.performanceinlighting.com



		OMBRA 500	OMBRA 1000	OMBRA 1500
CONSTRUCTION				
IP		IP66	IP66	IP66
IK		IK07 2J xx5	IK07 2J xx5	IK07 2J xx5
Dimensions (mm)		L 504 x H 100 x D 80	L 972 x H 100 x D 80	L 1440 x H 100 x D 80
Weight		max 3,49 kg	max 6,1 kg	max 8,54 kg
Colour		●	●	●
INSTALLATION				
Pre-wired		-	-	-
Quick		✓	✓	✓
Water Stop		-	-	-
Continuous mounted luminaire		-	✓	✓
LED				
Lightsource lumen output	3000 K	2016 lm	4032 lm	6064 lm
	4000 K	2016 lm	4032 lm	6064 lm
Luminaire lumen output	3000 K	1606 lm ÷ 1623 lm	3088 lm ÷ 3122 lm	4571 lm ÷ 4621 lm
	4000 K	1606 lm ÷ 1623 lm	3088 lm ÷ 3122 lm	4571 lm ÷ 4621 lm
CCT - Correlated Color Temperature		3000 K - 4000 K	3000 K - 4000 K	3000 K - 4000 K
CRI / SDCM (macadam step)		80/3	80/3	80/3
Lifetime		L80B10@60000h	L80B10@60000h	L80B10@60000h
OPTIC				
S/I symmetric narrow reflector		S/I 12°	S/I 12°	S/I 12°
S/M symmetric medium reflector		S/M 30°	S/M 30°	S/M 30°
ELL elliptical reflector		ELL 13°x36°	ELL 13°x36°	ELL 13°x36°
ELECTRICAL				
Wattage		20 W	38 W	54 W
Class		I	I	I
EEL		-	-	-
Ta MAX°C luminarie		35°C	35°C	35°C
Ta MIN°C luminarie		-20°C	-20°C	-20°C
Dimmable 1-10 V		-	-	-
Dimmable DALI		-	-	-
Emergency		-	-	-
COSφ ≥ 0,9		✓	✓	✓

● GR-11 / Anodised grey / Matt



OMBRA



Single mounting or linear compositions with a minimum distance between modules of 5mm.



Adjustable wall bracket in stainless steel.



Adjustable floor bracket in stainless steel.



Adjustable telescopic bracket in stainless steel.



Triangular shape, compact size.

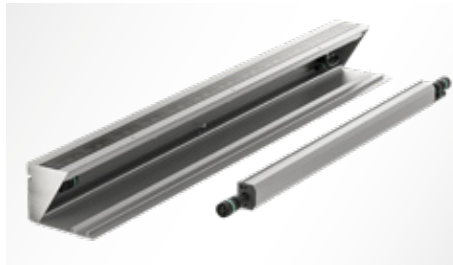

Replaceable, waterproof (IP 67) Power Supply Unit on board directly operated with line voltage (230/240V). Easy inspection, repairs.



Waterproof connectors for through-wiring of up to 50 m long lines.

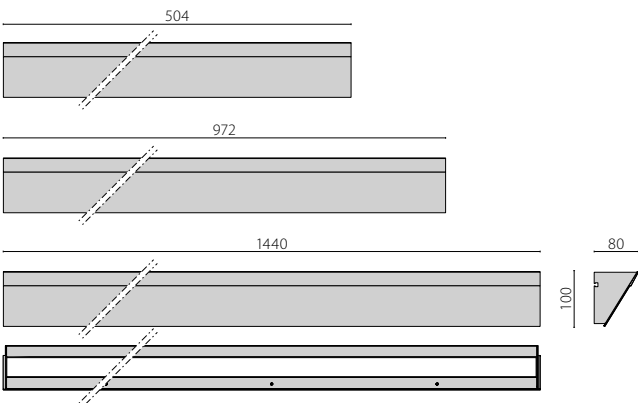



Casa Museo Maffei | Verona | Italy

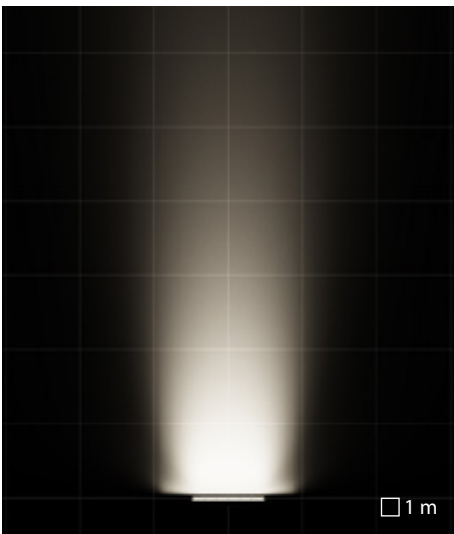

S/I symmetric narrow reflector

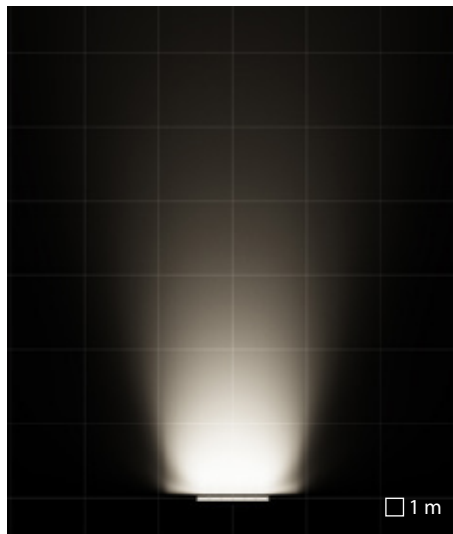

S/M symmetric medium reflector

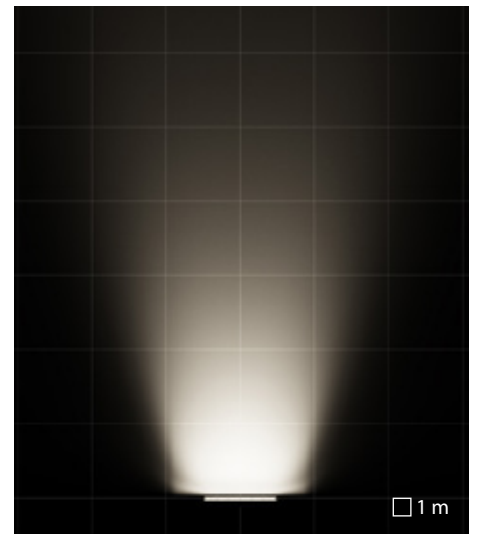

ELL elliptical reflector

TRACCIA

Light where is needed

Honored with the prestigious iF Design Award which is recognized internationally as a mark of design and manufacturing excellence. TRACCIA is an innovative recessed in-ground luminaire featuring a unique beam orientation mechanism for perfectly grazing and wall washing various surfaces from small to large-scale.

The product's formal language is subordinated to the architecture: light becomes the environment's main narrator, taking the center of the scene.

This system combines formal simplicity with high-performance standards to light up façades and other vertical elements in both public and private settings.

TRACCIA offers options and versatility due to a wide range of optics, anti-glare louvers and various color temperatures. Through-wiring and waterproof plug-in connectors enable for an extremely cost-efficient installation.





Sheikh Rashid Bin Mohammed mosque | Al Quoz - Dubai | UAE

TRACCIA

Linear in-ground series. Fixtures consist of:

Construction

- Extruded anodised aluminium housing
- Aluminium gear tray for high heat dissipation of components
- Glare suppression grid in technopolymer
- EPDM gasket
- Tempered glass diffuser, screen-printed inside
- Stainless steel locking screws

Electrical

- Built-in driver
- Available with ON-OFF driver and dimmable DALI

Installation

- Device for unique beam orientation between 0° and 30° degrees
- Through-wiring designed
- The product can be installed either individually or in seamless linear compositions
- External electrical connection with IP-rated QUICK connector, complete with cable
- Recessed box to be ordered separately
- Each recessed box is delivered with a protective cover to avoid possible deformations during the installation in concrete and spirit level to ease the levelling during installation
- For outdoor applications, provide drainage gravel for at least 300 mm additional to the appliance or a suitable drainage system

Variants

- For other colour temperatures and different colour rendering index consult factory
- TRACCIA RGBW DMX on request (consult factory).

Listings

- CE
- EAC
- RCM
- Compliant to EN 60598-2-13 A1 / A2 / A3 / A4 / A5 installation areas
- Made in Italy

Warranty

- 5-year limited warranty. Complete warranty terms located at www.performanceinlighting.com
- Registered trademark®



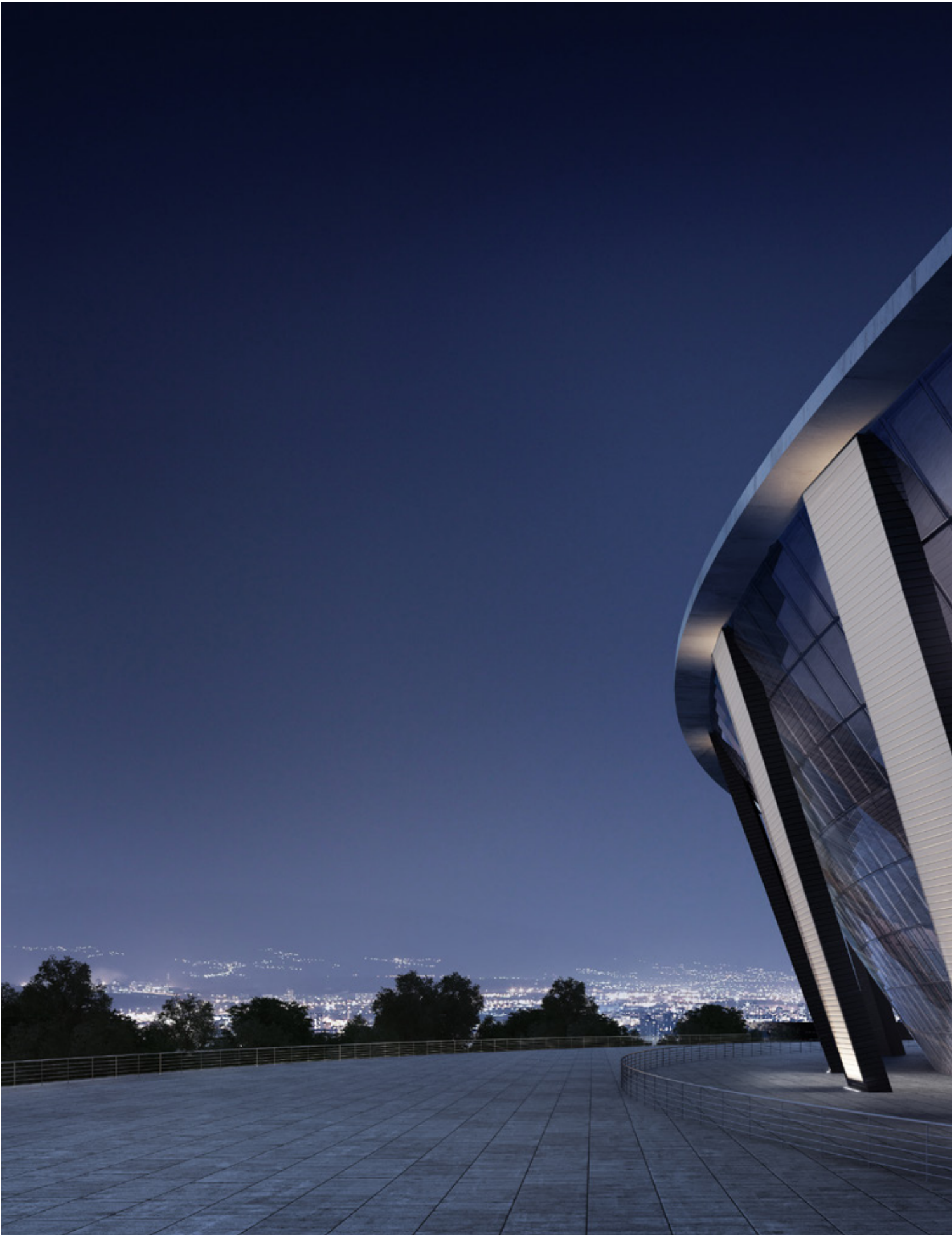

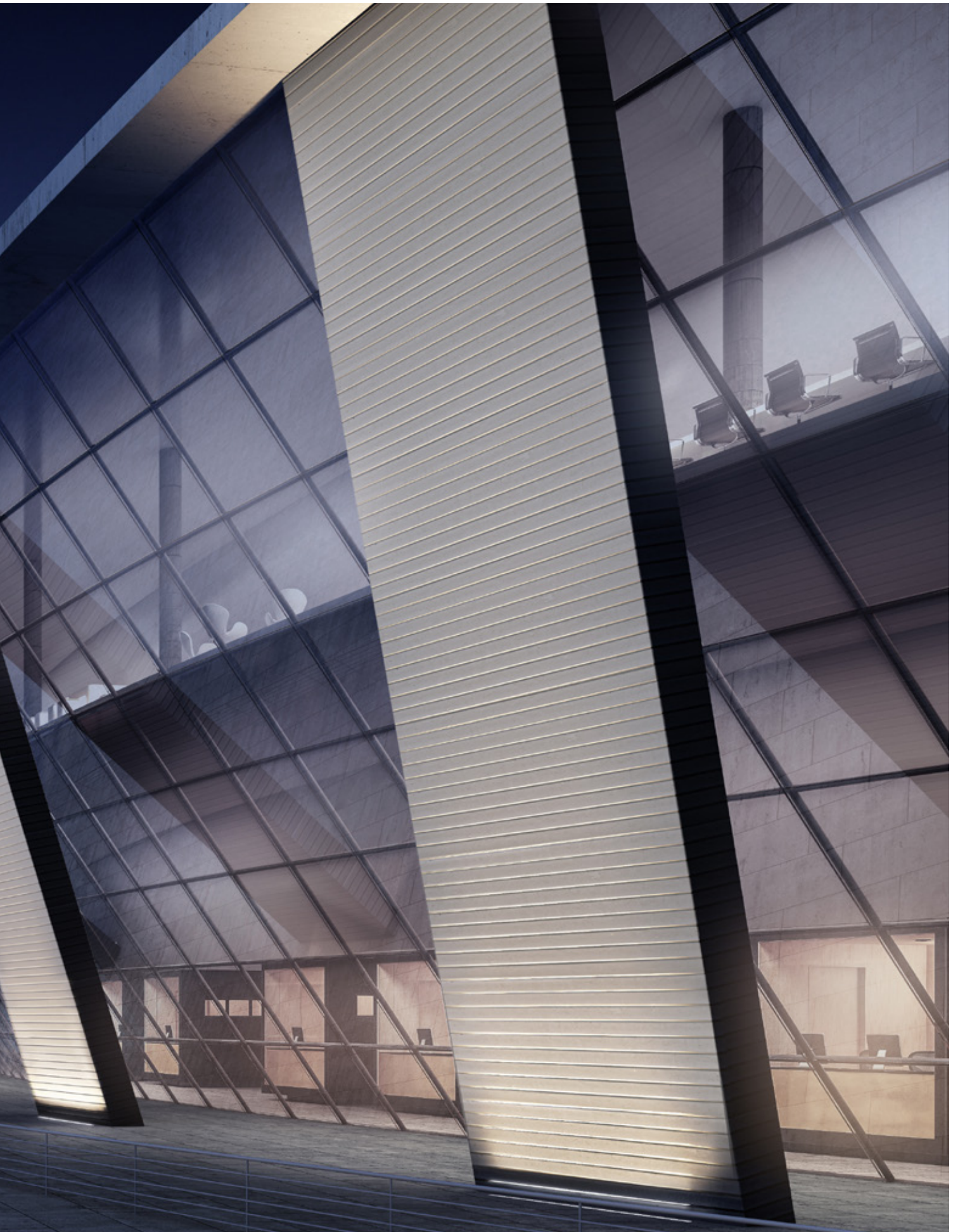



		TRACCIA 500	TRACCIA 1000	TRACCIA 1500
CONSTRUCTION				
IP		IP67	IP67	IP67
IK		IK10 20J xx9	IK10 20J xx9	IK10 20J xx9
Dimensions (mm)		L 525 x H 106 x D 98	L 1025 x H 106 x D 98	L 1525 x H 106 x D 98
Dimensions recessed fixing box (mm)		L 520 x H 142 x D 80	L 1020 x H 142 x D 80	L 1520 x H 142 x D 80
load torsion		max 2000 kg 5 kN 50 Nm	max 2000 kg 5 kN 50 Nm	max 2000 kg 5 kN 50 Nm
Weight		max 4,77 kg	max 8,73 kg	max 12,78 kg
Colour		●	●	●
INSTALLATION				
Pre-wired		-	-	-
Quick		✓	✓	✓
Water Stop		-	-	-
Continuous mounted luminaire		✓	✓	✓
LED				
Lightsource lumen output	3000 K	1900 lm	3800 lm	5700 lm
	4000 K	2000 lm	4000 lm	5700 lm
Luminaire lumen output	3000 K	1362 lm ÷ 1530 lm	2513 lm ÷ 2832 lm	3991 lm ÷ 4496 lm
	4000 K	1573 lm ÷ 1769 lm	2906 lm ÷ 3274 lm	4614 lm ÷ 5197 lm
CCT - Correlated Color Temperature		3000 K - 4000 K	3000 K - 4000 K	3000 K - 4000 K
CRI / SDCM (macadam step)		80/0	80/0	80/0
Lifetime		L80B10@60000h	L80B10@60000h	L80B10@60000h
OPTIC				
S/I symmetric narrow reflector		S/I 12°	S/I 12°	S/I 12°
S/M symmetric medium reflector		S/M 30°	S/M 30°	S/M 30°
ELL elliptical reflector		ELL 13°x36°	ELL 13°x36°	ELL 13°x36°
ELECTRICAL				
Wattage		21 W	42 W	63 W
Class		I	I	I
EEl		-	-	-
Ta MAX°C luminaire		35°C	35°C	35°C
Ta MIN°C luminaire		-20°C	-20°C	-20°C
Dimmable 1-10 V		-	-	-
Dimmable DALI		-	-	-
Emergency		-	-	-
COSφ ≥ 0,9		✓	✓	✓
STANDARDS				
UNI EN 60598-2-13		A1 - A2 - A3 - A4	A1 - A2 - A3 - A4	A1 - A2 - A3 - A4

● GR-11 / Anodised grey / Matt



Fisherman monument | Egmond aan Zee | Netherlands

TRACCIA

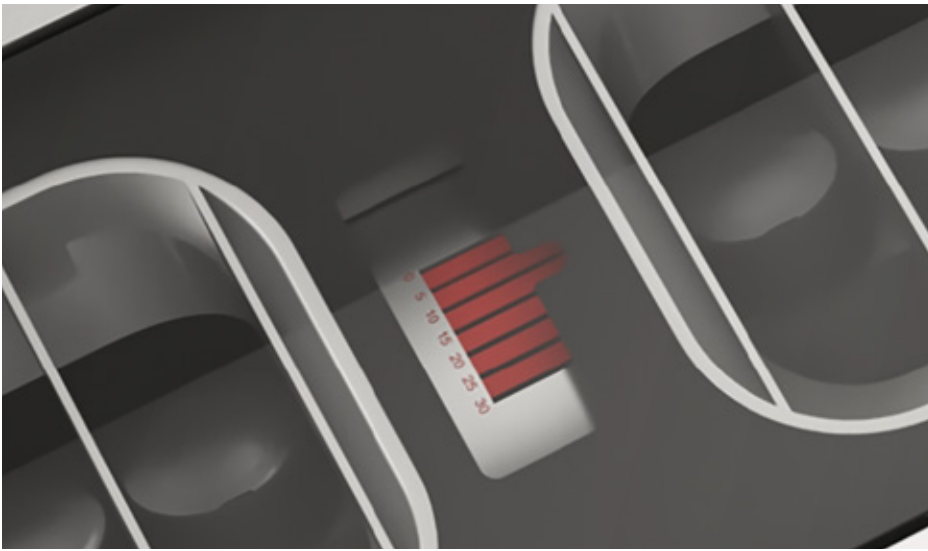

Asymmetric light sources, exclusive device for beam orientation between 0 and 30 degrees.



Unique beam orientation mechanism for a perfect grazing and wall washing illumination of small and large or very large surfaces.

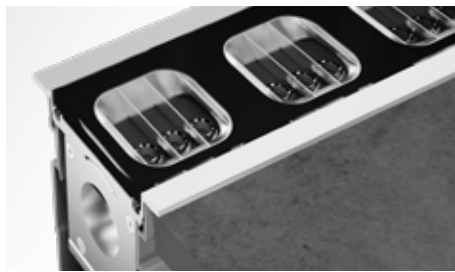

Frame version.

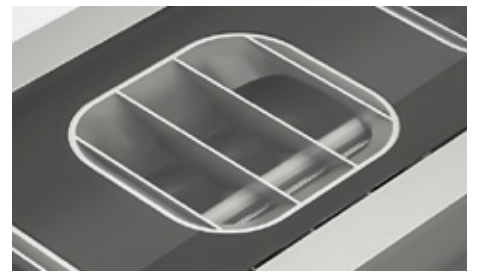

Anti-glare louvers.

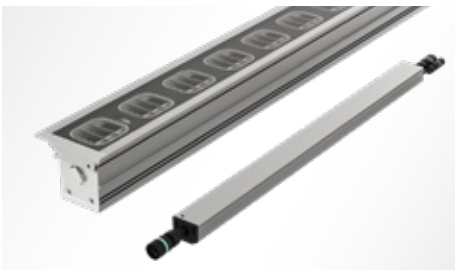

Replaceable, waterproof (IP 67) Power Supply Unit directly operated with line voltage (230/240V). Easy inspection, repairs, replacement and connections.



Modules can be installed single or in uninterrupted linear compositions. Waterproof connectors for through-wiring of up to 50 m long lines.



Suitable for low speed transit of vehicles with inflated tyres.

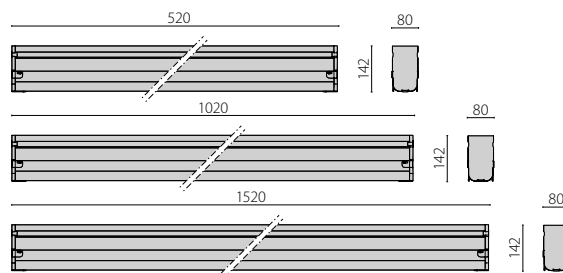
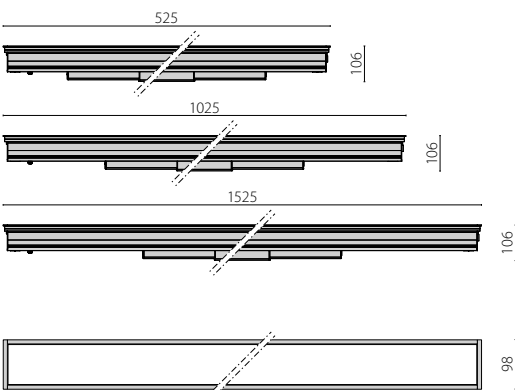



Sheikh Rashid Bin Mohammed mosque | Al Quoz - Dubai | UAE

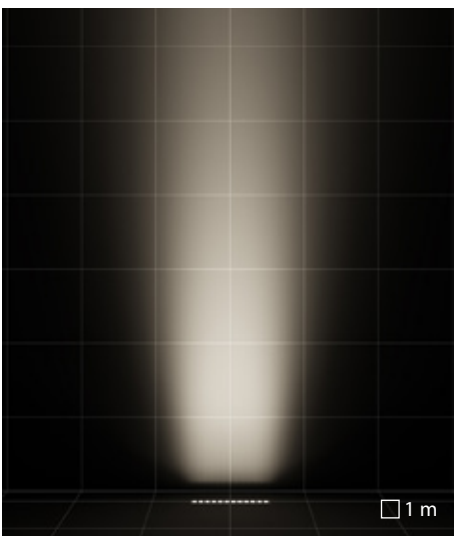

S/1 symmetric narrow reflector

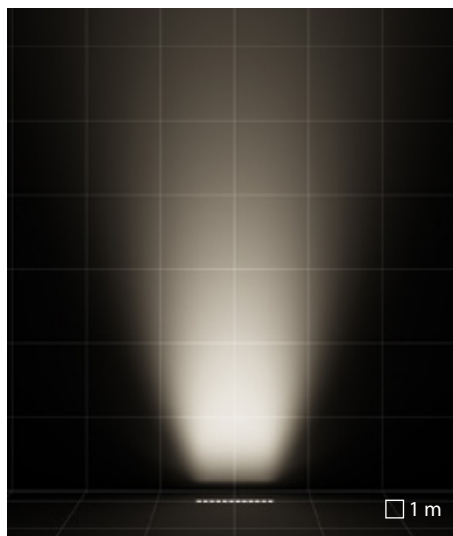

S/M symmetric medium reflector

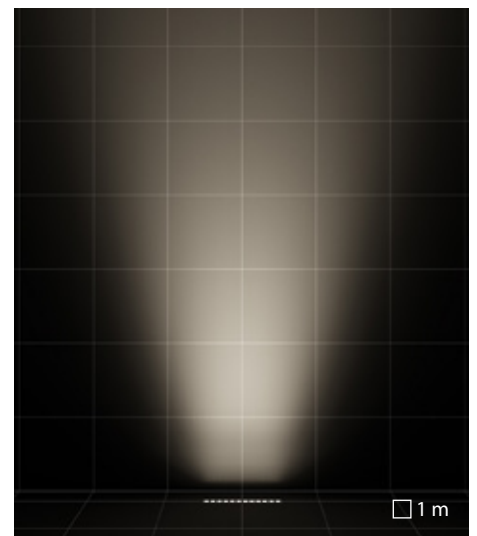

ELL elliptical reflector





GROOVE

design artec3 Studio

Ariadne's thread

Just like the myth, the GROOVE is the perfect pathfinder. This unique luminaire can be the ideal accent for numerous projects. The GROOVE guarantees maximum luminous efficiency. The satin coating assures lumen uniformity and absolutely no visibility of the LED source. You will make a statement when choosing the GROOVE for your next project. Curved modules. Minimalistic. Sleek. Walk and Drive-Over. Be creative. GROOVE.





GROOVE 21

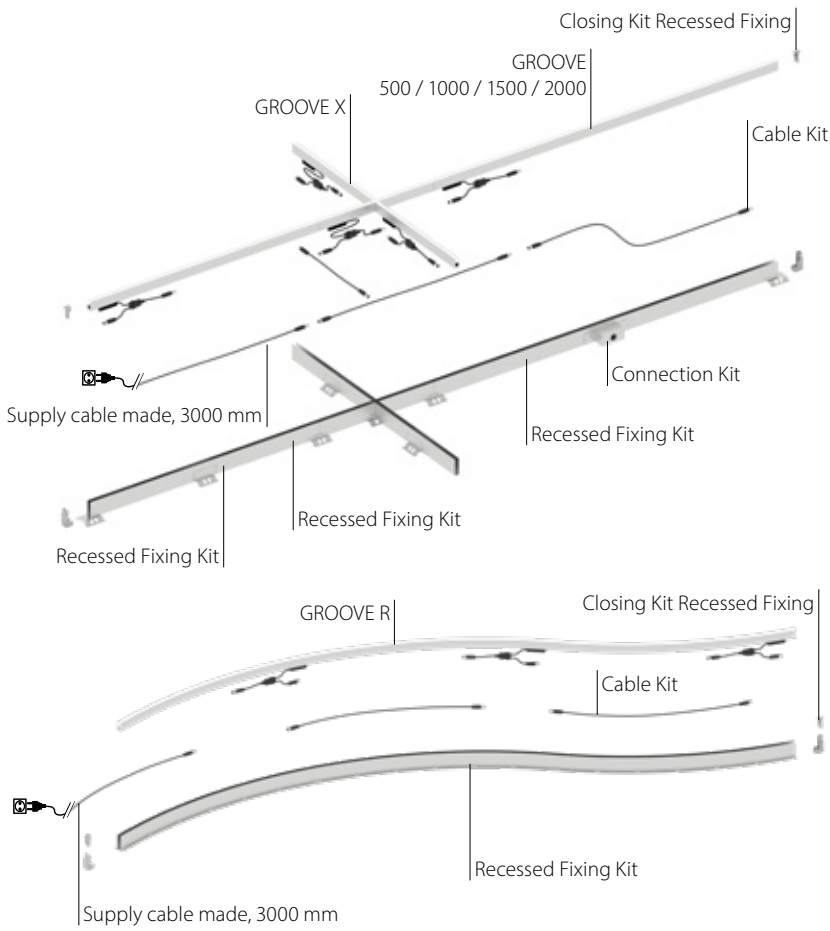
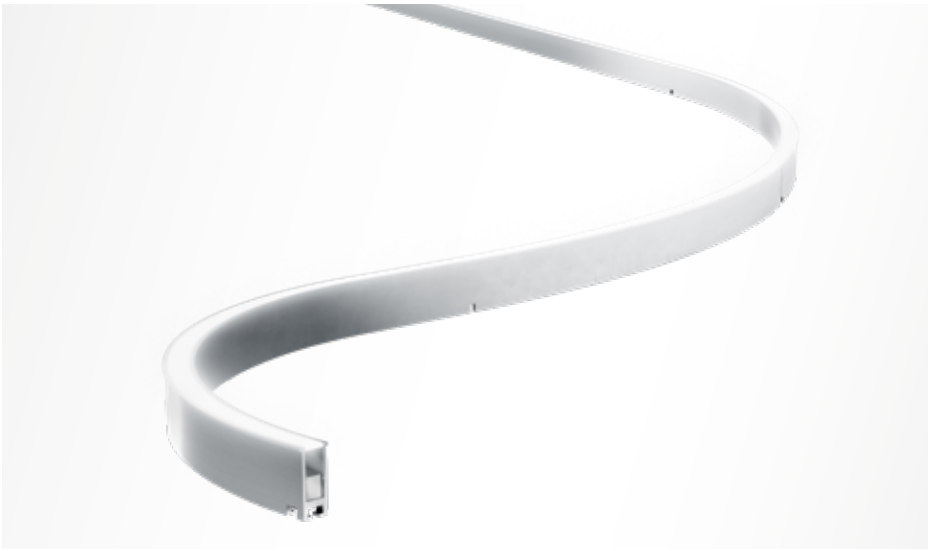

CONFIGURATOR LIGHT-PERFORMER®
www.light-performer.com

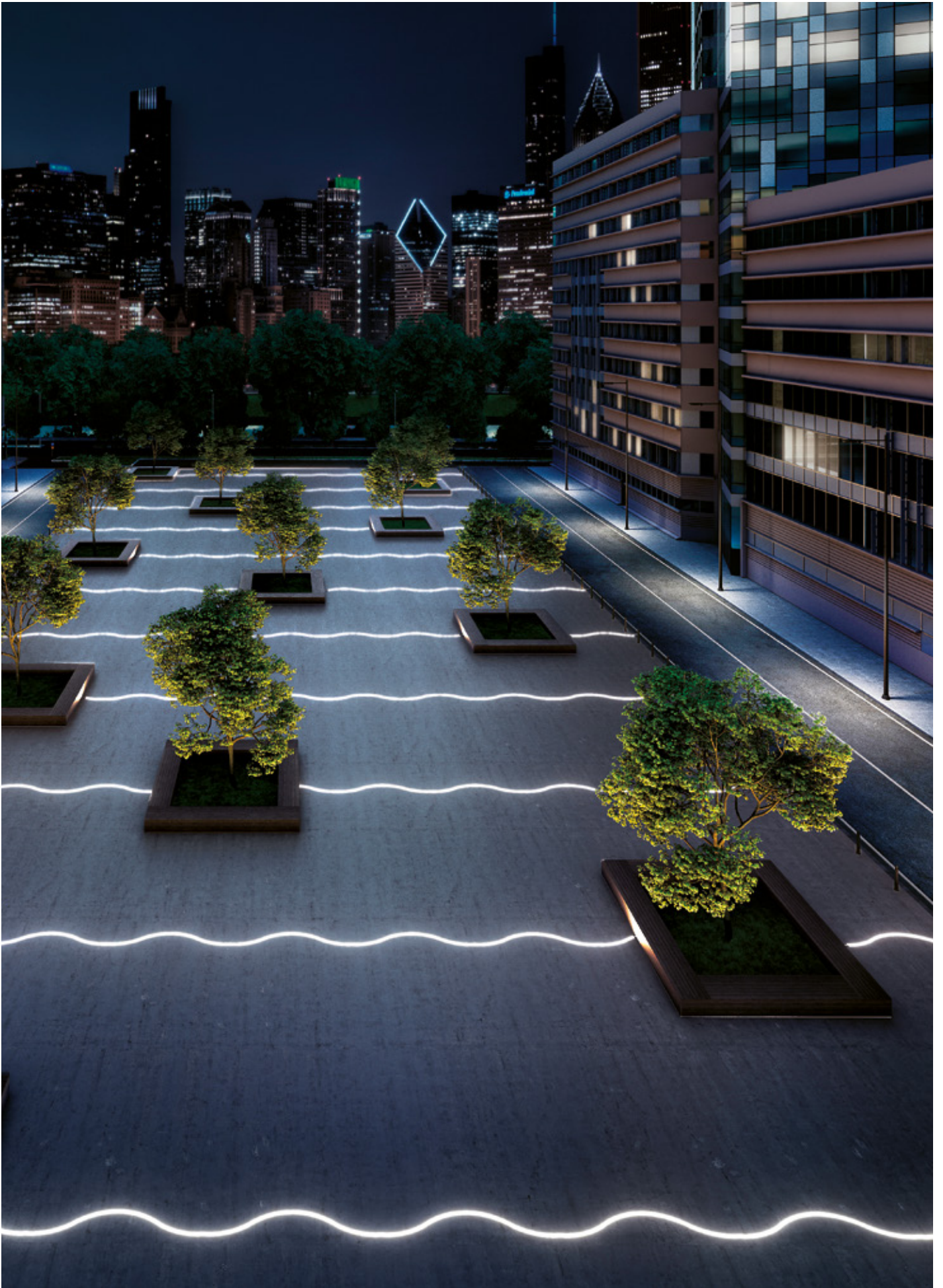



WAYFINDING

The orientation light collection



The term Way Finding does not only mean “how to find your way” but it contains a broader and complex meaning... it’s about cities, spaces to live in, in which we move and orientate ourselves every day. Kevin Lynch, an American city planner and architect, coined this term in 1960 in his book “The Image of the City” where he focused the attention on “urban signs” such as streets or house numbers understood as ways to organize spaces, constructed or not, and how to equip them to make them readable and visible, by helping us to orientate ourselves. The Way Finding or orientation lighting also includes a lot of other elements, such as street furnishing, coatings, green areas,

signage lighting, light. To focus light on paths, be they driveways, sidewalks or staircases, is certainly an instrument that helps space to become a “friend”, able to dialogue with us and acquiring at the same time “cognition of space” that surrounds us. Orientation lighting furthermore supports perception through the creation of illuminating dots and lines, for example, in passages and on the stairs.

INSERT+

Walk with safety

The designers at PERFORMANCE IN LIGHTING are never satisfied, and their quest for the perfect step light has given light to the INSERT+ series. With a discreet aperture to maximize visual comfort without sacrificing output, this piece provides the perfect step light with an elegant aesthetic at an unrefined price point. The simplest of fixtures can easily integrate into the exterior of your project traditionally or serve inside as a contemporary element in hallways and patient rooms. The INSERT+ series offers a distinct look while managing to be integrated into nearly every project subtly.

The initial INSERT+ family comes in three sizes for residential applications. Over time a ZERO version, with no visible screws available too (CLIPS), and a professional large size INSERT+ 3, conceived for public applications, have completed this series, making it one of the most versatile and broad on the market.

A solid brass faceplate option (MARINE) is also available for INSERT+ 1 which can be used in marine contexts.

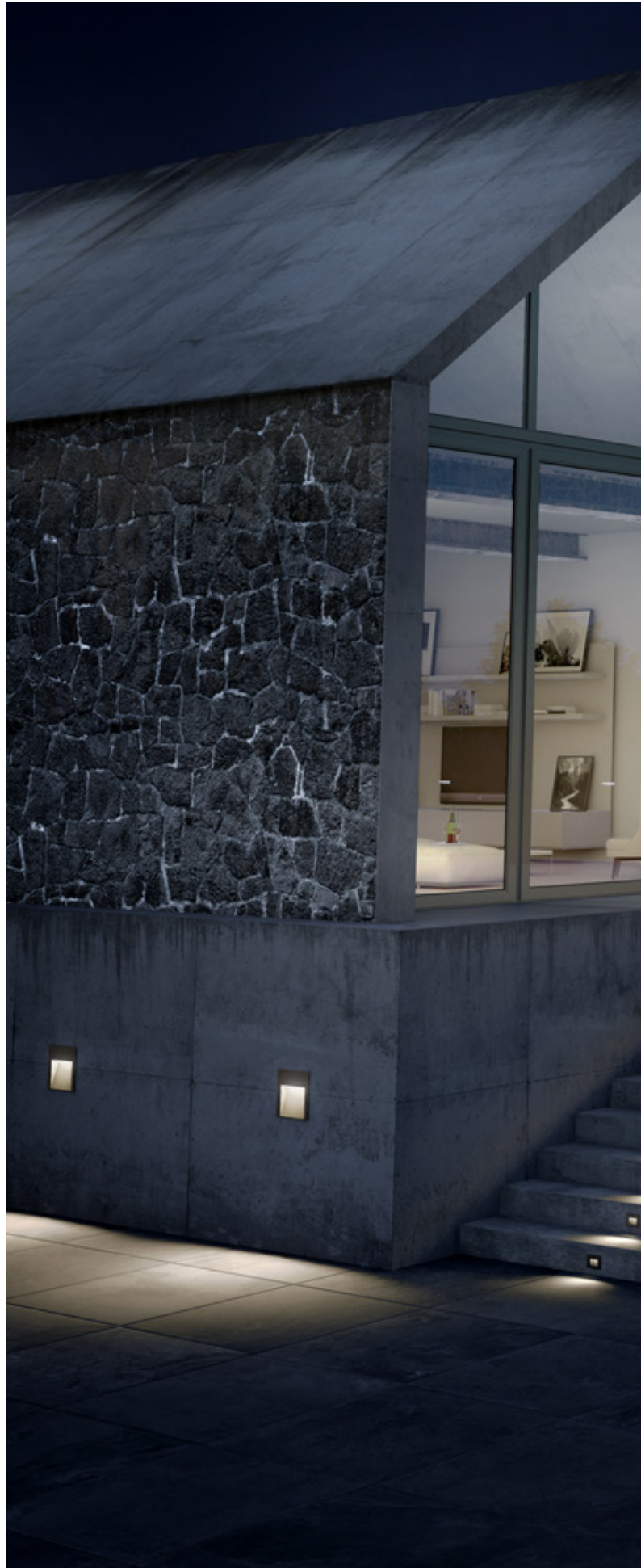

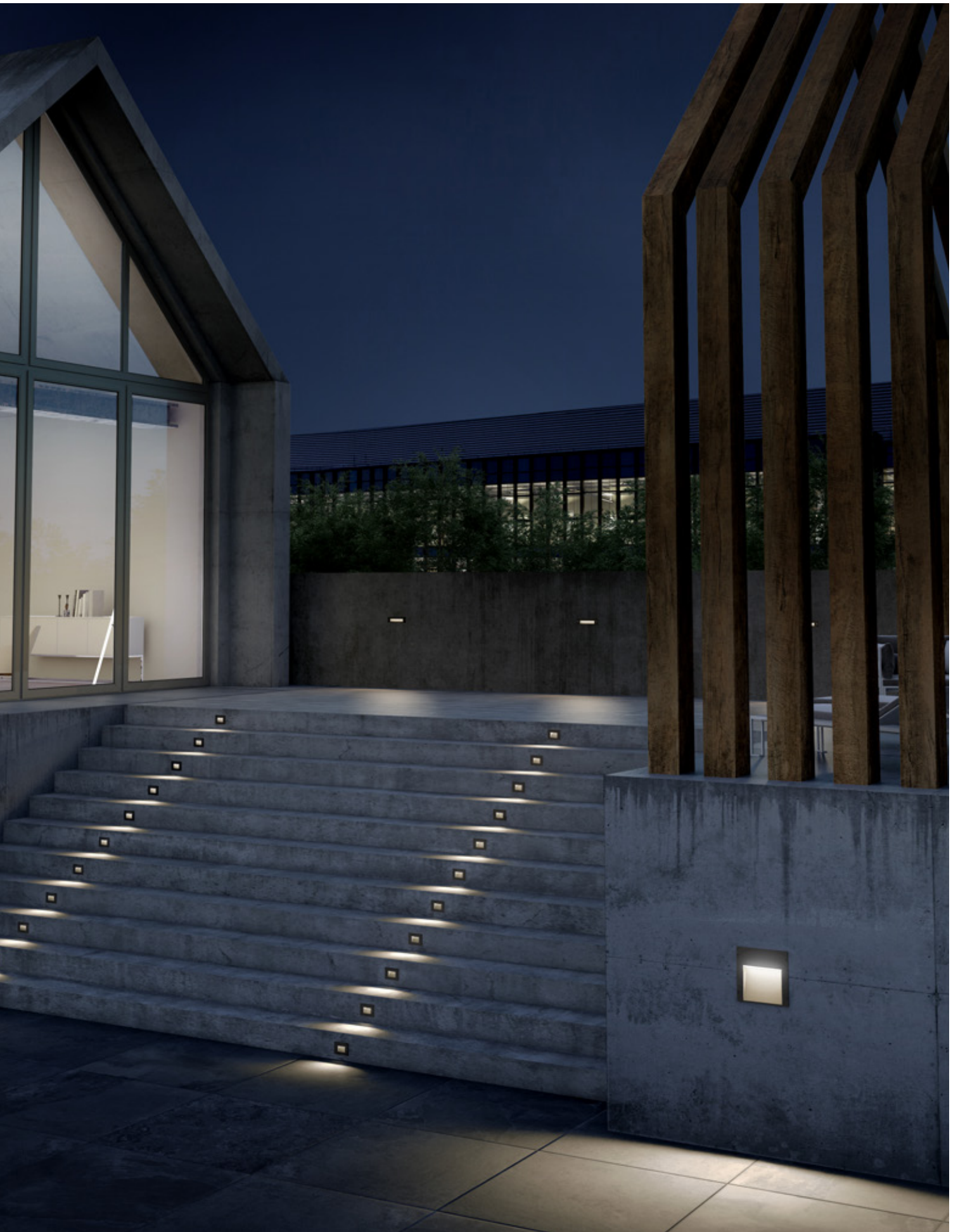

INSERT+

Recess wall step light series. Fixtures consist of:

Construction

- Die-cast aluminium housing, powder-polyester coated ISO 9227
- Anti-ageing silicone gasket
- Flat glass diffuser, matt inside
- Stainless steel locking screws

Electrical

- Built-in driver

Installation

- 503 standard recessed box included in the product (INSERT+ ZERO / ZERO CLIPS)
- All INSERT+ 1 / 2 recessed fixing kits are equipped with a cover with spirit levels to facilitate correct position during installation
- Each recessed box is delivered with a protective cover to avoid possible deformations during the installation in concrete and spirit level to ease the levelling during installation
- For the INSERT+ 2 series, connectors for through wiring connections are available as accessories. Connectors fit wires measuring Ø 7 - Ø 10.5 mm and Ø 14 - Ø 17 mm

Listings

- CE
- EAC
- RCM
- Made in Italy

Warranty

- 5-year limited warranty. Complete warranty terms located at www.performanceinlighting.com
- Registered trademark®





INSERT+ ZERO

INSERT+ ZERO CLIP

CONSTRUCTION		INSERT+ ZERO	INSERT+ ZERO CLIP
IP		IP65	IP65
IK		IK08 5J xx5	IK08 5J xx5
Dimensions (mm)		L 105 x H 75 x D 49	L 105 x H 75 x D 49
Dimensions recessed fixing box (mm)		-	-
Weight		max 0,28 kg	max 0,31 kg
Colour		○●●	○●●
INSTALLATION			
Pre-wired		-	-
Quick		-	-
Water Stop		-	-
Continuous mounted luminaire		✓	✓
LED			
Lightsource lumen output	3000 K	511 lm	511 lm
	4000 K	530 lm	530 lm
Luminaire lumen output	3000 K	125 lm	142 lm
	4000 K	142 lm	143 lm
CCT - Correlated Color Temperature		3000 K - 4000 K	3000 K - 4000 K
CRI / SDCM (macadam step)		80/3	80/3
Lifetime		L90B10@36000h	L80B10@60000h
OPTIC			
A/M asymmetric medium reflector		-	A/M
A/W asymmetric wide reflector		-	-
A25/W asymmetric wide reflector		-	-
A26/W asymmetric wide reflector		-	-
A29/M asymmetric medium reflector		A29/M	-
A37/M asymmetric medium reflector		-	-
ELECTRICAL			
Wattage		4,5 W	4,5 W
Class		I	I
EEL		-	-
Ta MAX°C luminarie		45°C	45°C
Ta MIN°C luminarie		-20°C	-20°C
Dimmable 1-10 V		-	-
Dimmable DALI		-	-
Emergency		-	-
COSφ ≥ 0,9		✓	✓

- GR-94 / Metallic grey / Textured
- AN-96 / Anthracite gray / Textured
- WH-87 / White / Textured
- BR-10 / Natural brass / Glossy



INSERT+ 1

INSERT+ 1 MARINE

INSERT+ 2

INSERT+ 3

INSERT+ 1	INSERT+ 1 MARINE	INSERT+ 2	INSERT+ 3
IP65	IP65	IP65	IP66
IK07 2J xx5	IK07 2J xx5	IK07 2J xx5	IK10 20J xx9
L 224 x H 55 x D 64	L 224 x H 55 x D 64	L 284 x H 88 x D 59	L 284 x H 284 x D 90
L 220 x H 51 x D 88	L 220 x H 51 x D 88	L 280 x H 85 x D 100	L 324 x H 274 x D 105
max 0,46 kg	max 0,61 kg	max 0,74 kg	max 2 kg
○ ● ●	●	○ ● ●	● ●
-	-	-	-
✓	✓	✓	✓
-	-	-	-
-	-	✓	-
825 lm	825 lm	1350 lm	3450 lm ÷ 4020 lm
850 lm	850 lm	1410 lm	3585 lm ÷ 4140 lm
250 lm	325 lm	503 lm	1388 lm ÷ 1502 lm
275 lm	354 lm	553 lm	1399 lm ÷ 1592 lm
3000 K - 4000 K	3000 K - 4000 K	3000 K - 4000 K	3000 K - 4000 K
80/3	70/3	80/3	70/5 - 80/3
L80B10@60000h	L80B10@60000h	L80B10@60000h	L80B10@125000h L80B10@60000h
-	-	-	-
-	-	-	A/W
-	-	A25/W	-
-	-	-	A26/W
-	-	-	-
A37/M	A37/M	-	-
6 W	6 W	10 W	26 W - 27 W
I	I	I	I
-	-	-	-
35°C	35°C	35°C	35°C
-10°C	-10°C	-20°C	-20°C
-	-	-	-
-	-	-	-
-	-	-	-
✓	✓	✓	✓

INSERT+ ZERO / ZERO CLIP



Painted die-cast aluminium housing.

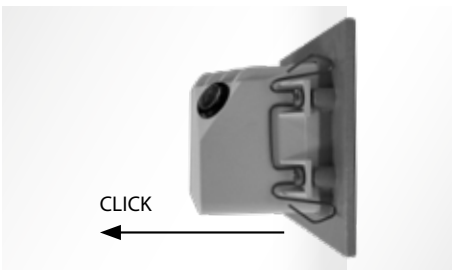

Stainless steel springs for quick connection to recessed box. (INSERT+ ZERO CLIP)



Ideal to light pedestrian walkways.

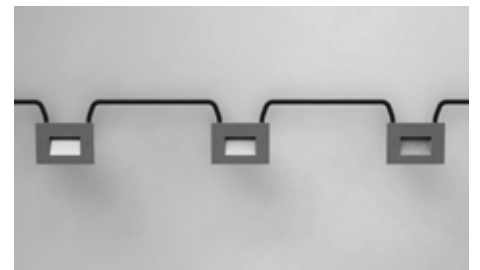

The fitting is suitable for through-wiring.



Recessed Box (503) included.



Anti-tamper kit available as an accessory.

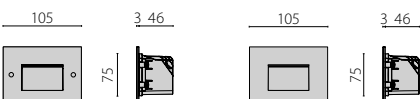

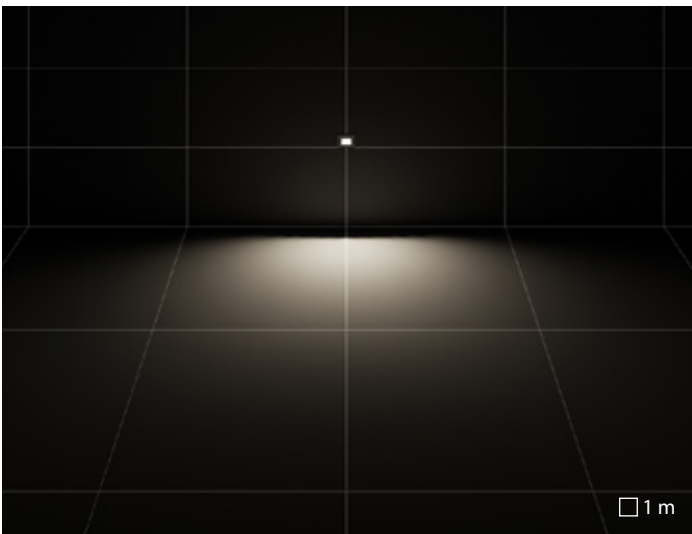

A29/M asymmetric medium reflector

INSERT+ 1 / 1 MARINE

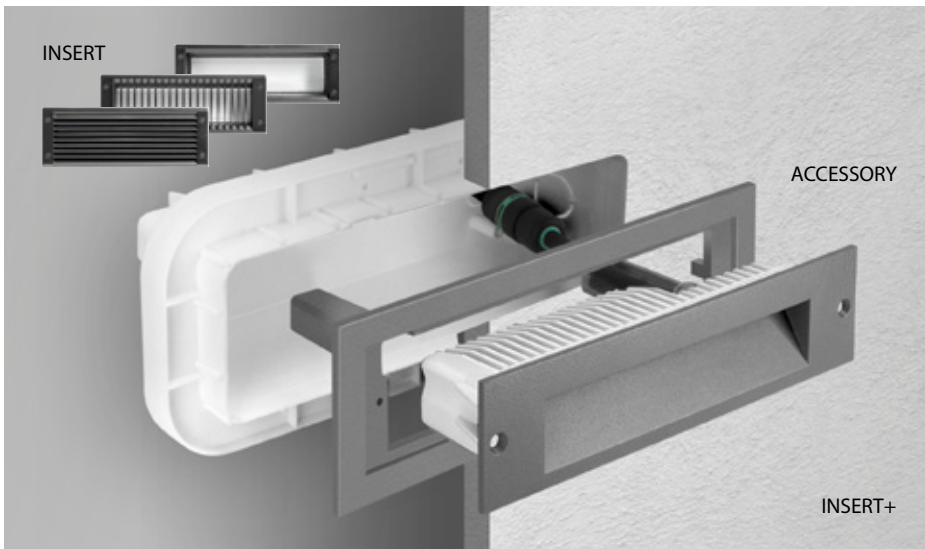

INSERT+ 1 could be installed in existing recess boxes of INSERT 1 thanks to the dedicated adapter accessory.



The product is provided pre-cabled with brass cable clamp.



All INSERT+ recessed fixing kits are equipped with a cover with spirit levels to facilitate correct position during installation.



INSERT+ 1 fits perfectly in standard European brick dimensions.



Luminaire is supplied pre-wired with 20 cm of cable H07RN-F (standard).

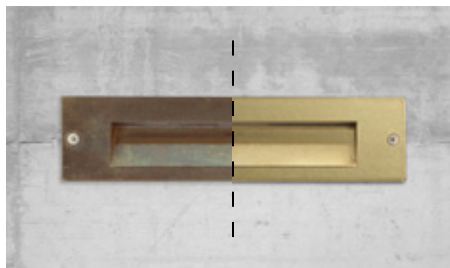

Metals with natural finish surface may oxidise with age. To restore the original brightness use commercial metal polish.



Other products in MARINE version (consult factory)

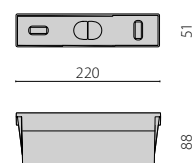
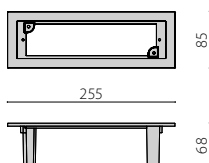
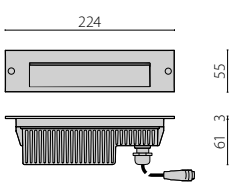

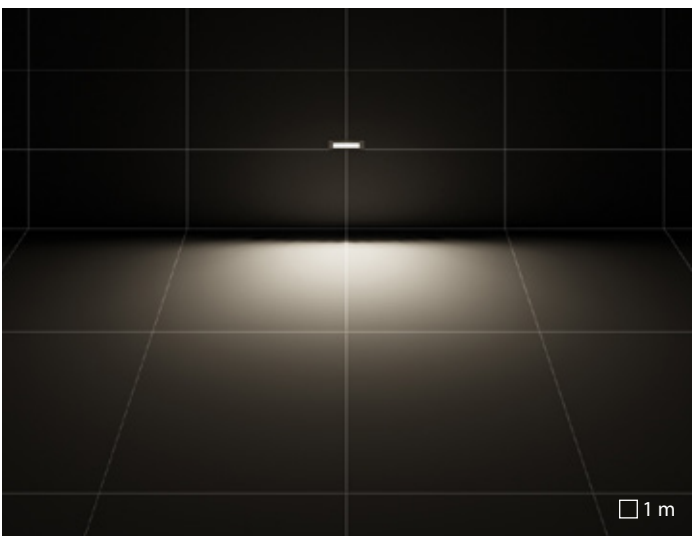

A37/M asymmetric medium reflector





Private villa | Almería | Spain

INSERT+ 2

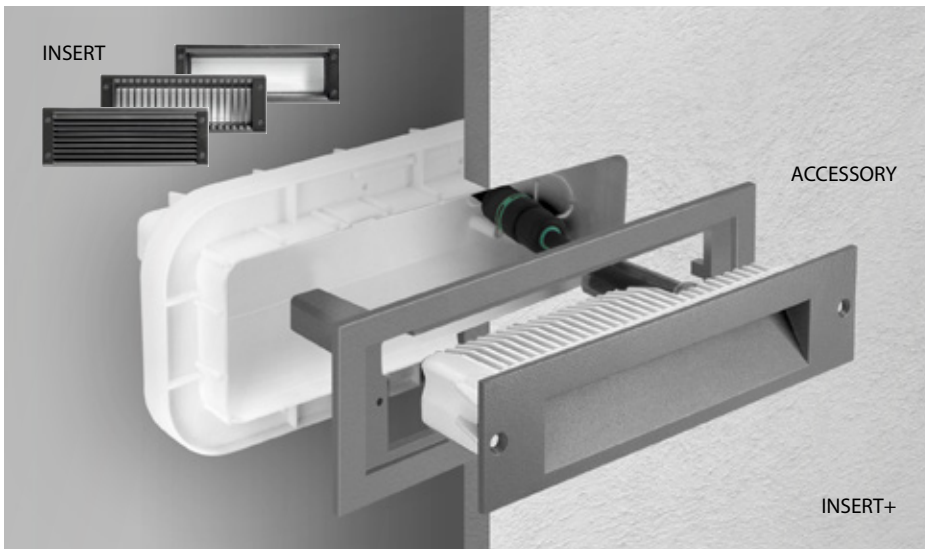

INSERT+ 2 could be installed in existing recess boxes of INSERT 2 thanks to the dedicated adapter accessory.



The product is provided pre-cabled with brass cable clamp.



All INSERT+ recessed fixing kits are equipped with a cover with spirit levels to facilitate correct position during installation.

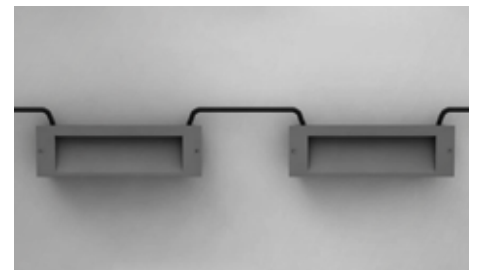

The fitting is suitable for through-wiring.



Available for through wiring as accessories.



Anti-tamper kit available as an accessory.

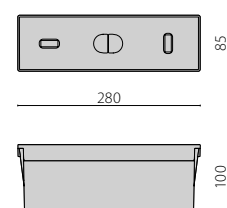
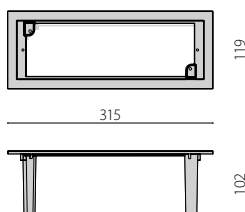
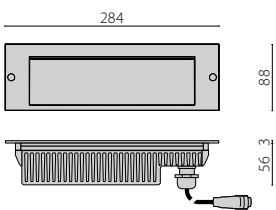



Seligerskaya metro station | Moscow | Russia

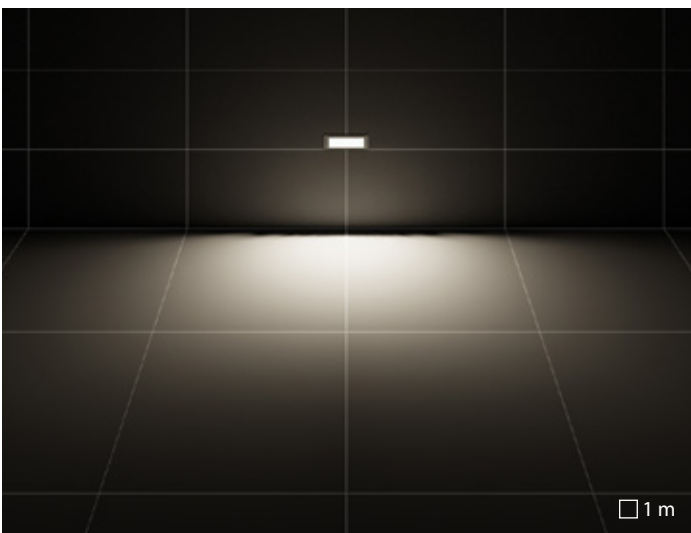

A25/W asymmetric wide reflector

INSERT+ 3



A26/W
Tempered clear glass diffuser.

A/W
Diffuser in flat glass, internally frosted.



External electrical connection with sealed plug-socket QUICK, complete with cable.



The fixture requires recessed fixing box which must be ordered separately.



Available for thorough wiring as accessories.



Anti-tamper kit available as an accessory.

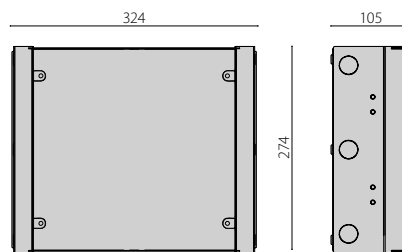
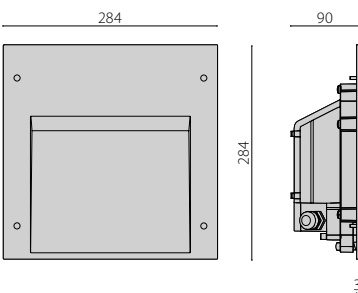

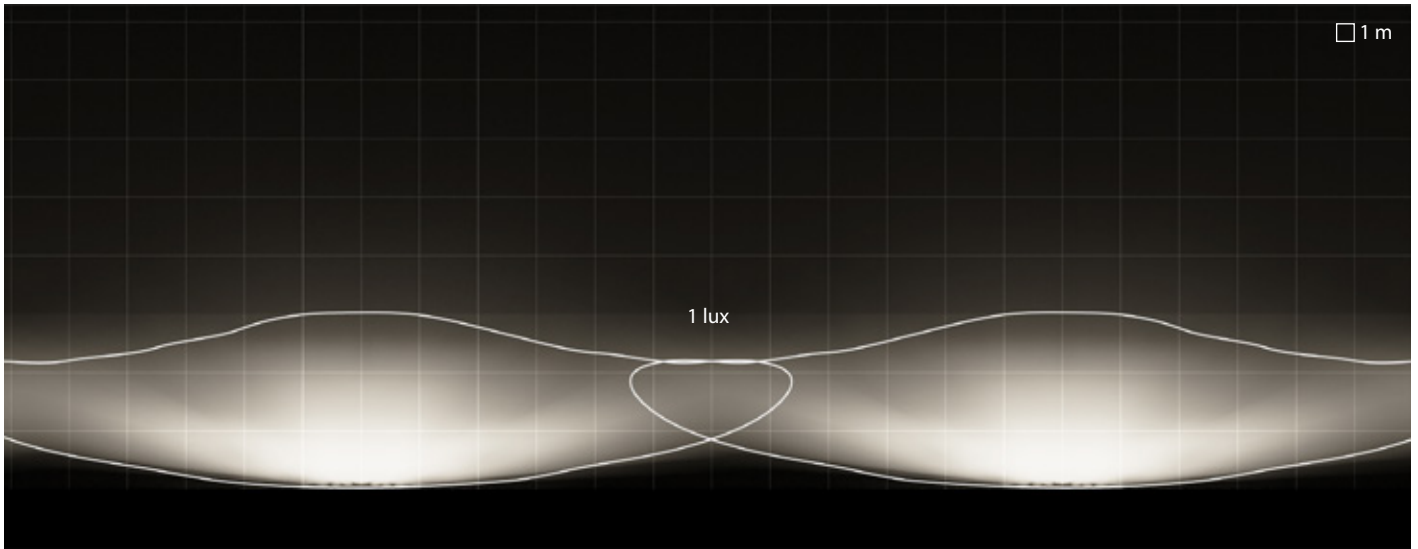

A26/W asymmetric wide reflector

Luminaire spacing = 12m
 Path depth = 3m
 Mounting height = 1m

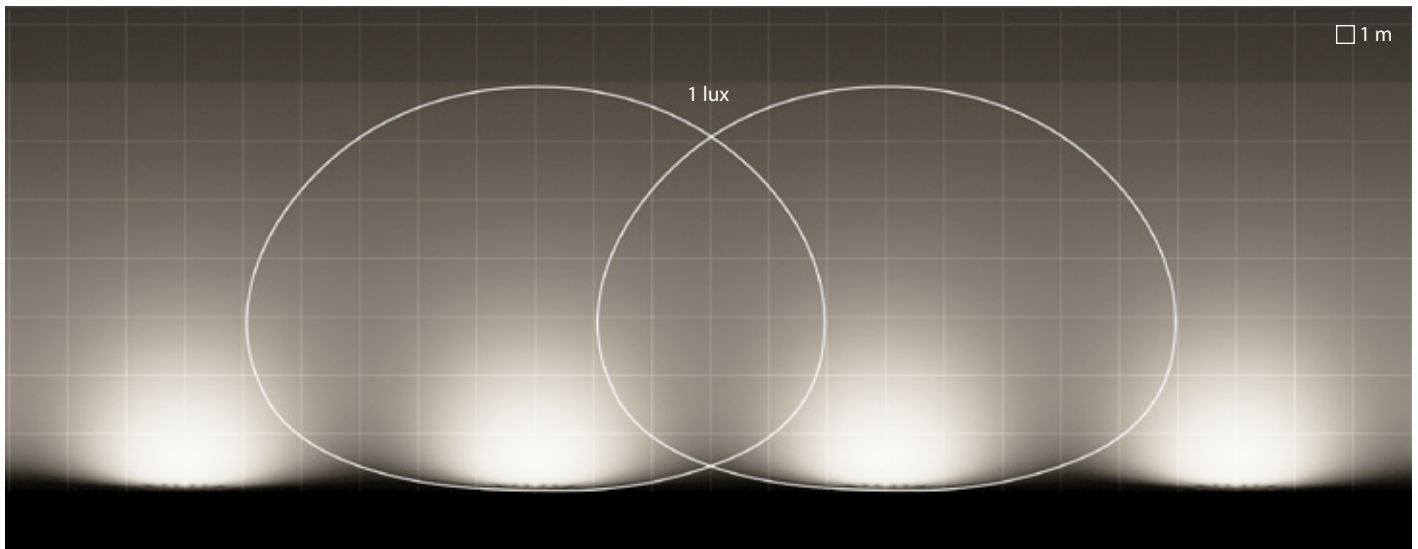

A/W asymmetric wide reflector

Luminaire spacing = 6m
 Path depth = 7m
 Mounting height = 1m

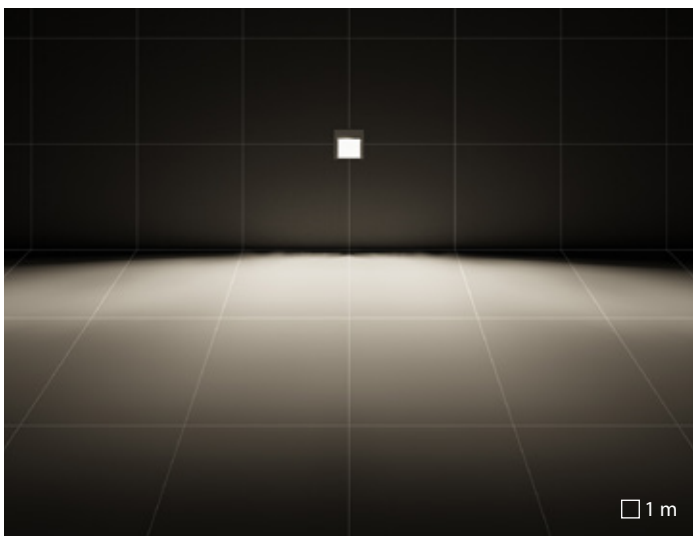

A26/W asymmetric wide reflector

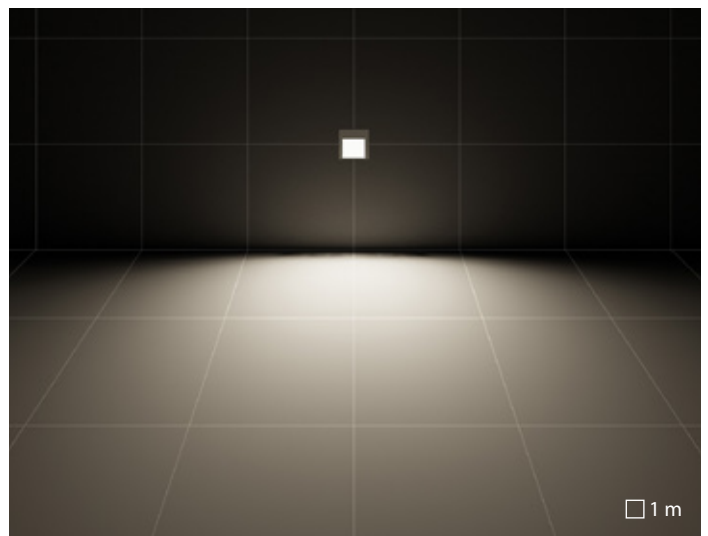

A/W asymmetric wide reflector

MASK+

design Roberto Fiorato

Void, Light, Plane

Artificial light plays an essential role in the environment during night-time: it provides orientation, transmits mood and emotions, and draws attention.

MASK+ is an elegant, dynamic balance between full and empty, where the void is presented as an object that identifies and distinguishes the shape by characterizing it. The light embraces this emptiness filling it, signifying the context both inside and outside, both day and night.

This series, unique in the market, available in two sizes and two shapes, allows to decorate interiors and exteriors using a unique coordinated image, its minimal yet majestic design will add elegance to any contemporary space.





MASK+

design Roberto Fiorato

Wall and ceiling mounted luminaire for indoor and outdoor, comprising:

Construction

- Die-cast aluminium housing, powder-polyester coated ISO 9227
- Anti-ageing silicone gasket
- Glass diffuser, internally painted for homogeneous diffused light

Electrical

- Built-in driver
- EM/1P are maintained emergency versions (1h)
- PIR versions have a motion sensor fitted into the ring, suitable for resistive and inductive load

Installation

- M versions, i.e. single emission, are supplied with a single light source and are designed to allow a single sided light output either upwards or downwards
- Double installation position is possible to obtain different lighting effects

Variants

- DALI dimmable ballast available. Consult factory

Listings

- CE
- EAC
- RCM
- Made in Italy

Warranty

- 5-year limited warranty. Complete warranty terms located at www.performanceinlighting.com
- Registered trademark ®
- Registered design ®

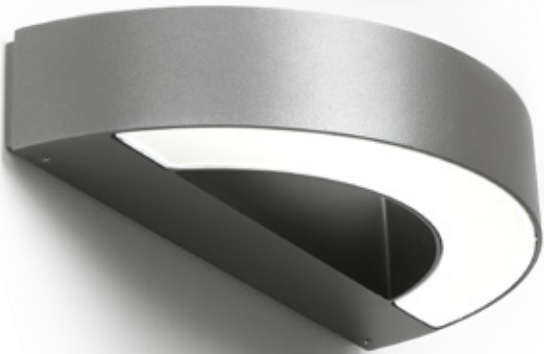



MASK+ MINI

MASK+

MASK+ ROUND

CONSTRUCTION				
IP		IP65	IP65	IP65
IK		IK05 0.70J xx3	IK06 1J xx3	IK06 1J xx3
Dimensions (mm)		L 265 x H 45 x D 138	L 326 x H 62 x D 168	L 275 x H 348 x D 68,5
Weight		max 1,38 kg	max 2,59 kg	max 2,31 kg
Colour		●○	●○	●○
INSTALLATION				
Pre-wired		-	-	-
Quick		-	-	-
Water Stop		-	-	-
Continuous mounted luminaire		-	-	-
LED				
Lightsource lumen output	3000 K	733 lm ÷ 1450 lm	1552 lm ÷ 3104 lm	2590 lm
	4000 K	733 lm ÷ 1450 lm	1552 lm ÷ 3336 lm	2650 lm
Luminaire lumen output	3000 K	317 lm ÷ 627 lm	914 lm ÷ 1770 lm	1188 lm
	4000 K	340 lm ÷ 670 lm	971 lm ÷ 1879 lm	1227 lm
CCT - Correlated Color Temperature		3000 K - 4000 K	3000 K - 4000 K	3000 K - 4000 K
CRI / SDCM (macadam step)		80/3	80/3	80/3
Lifetime		L70B10@54000h	L70B10@50000h	L70B10@54000h
OPTIC				
S/EW symmetric extra wide reflector		S/EW	S/EW	S/EW
ELECTRICAL				
Wattage		8 W - 16 W	24 W - 12,5 W	22 W
Class		I	I	I
EEL		-	-	-
Ta MAX°C luminaire		35°C	35°C	35°
Ta MIN°C luminaire		-20°C	-20°C	-20°
Dimmable 1-10 V		-	-	-
Dimmable DALI		-	-	-
Emergency		-	1 h	-
COSφ ≥ 0,9		✓	✓	✓

● AN-96 / Anthracite gray / Textured
 ○ WH-87 / White / Textured



MASK+ / MASK+ MINI



Double installation position is possible to obtain different lighting effects.



Glass diffuser, internally painted for homogeneous diffused light.

No visible screws.

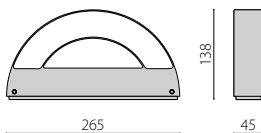
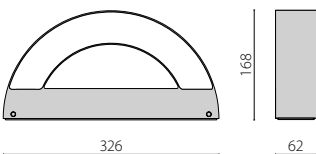

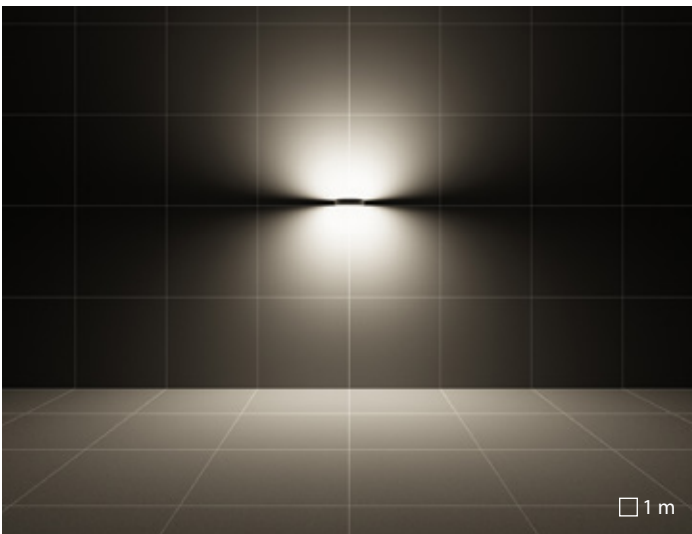

MASK+ B | S/EW symmetric extra wide reflector

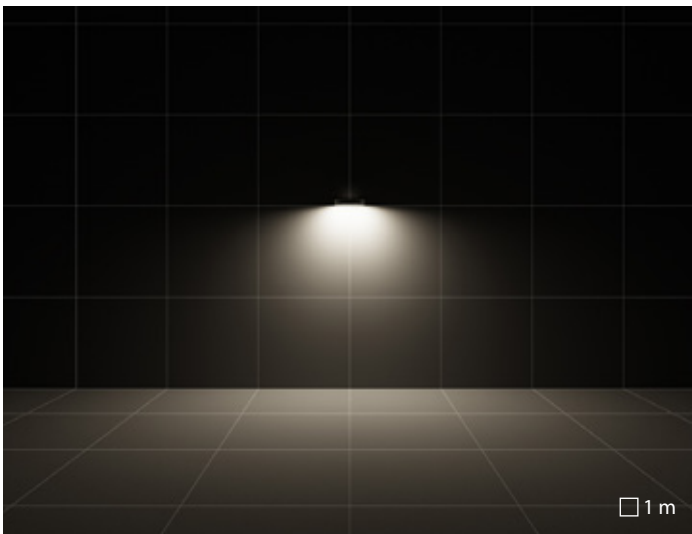

MASK+ M | S/EW symmetric extra wide reflector

MASK+ ROUND

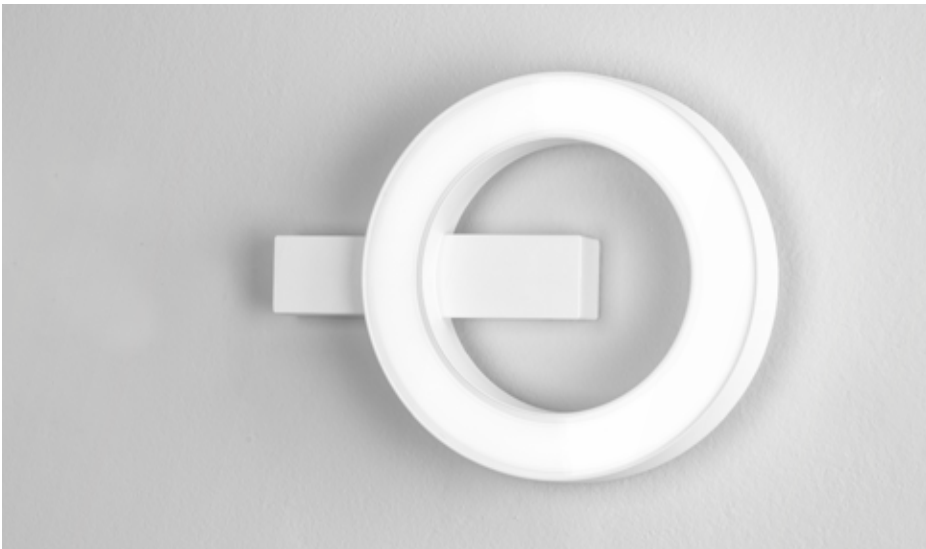

Glass diffuser, internally painted for homogeneous diffused light.



No visible screws.



PIR versions have a motion sensor fitted into the ring, suitable for resistive and inductive load

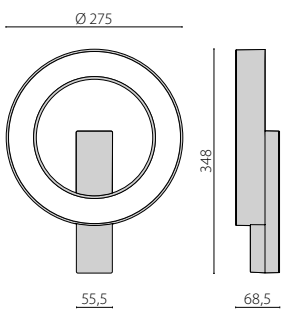

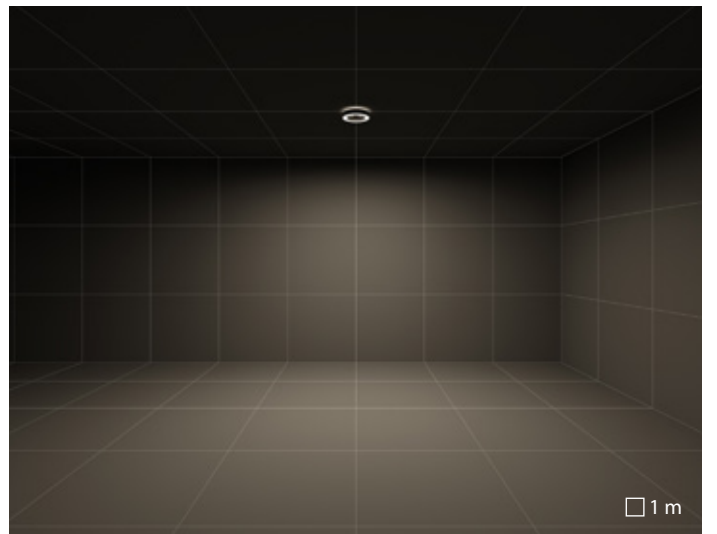
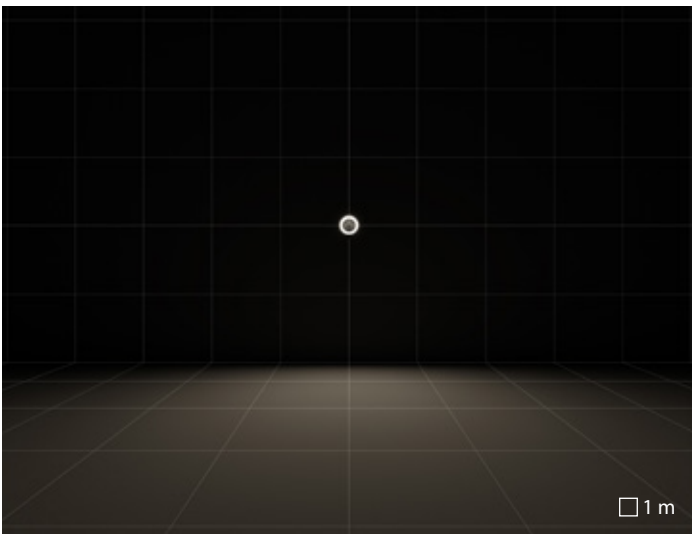

MASK+ ROUND | S/EW symmetric extra wide reflector

MIMIK

Much more than a pretty face

Unobtrusive and elegant, like chameleons, these units perfectly blend with the interior of the architectural space, creating an effect of luminous mimicry.

Ultra-flat luminaires conceived entirely around LED optics and using the latest generation LED sources, are suitable for any application requiring a wall mount luminaire. Its minimal design and reduced thickness allow for discreet integration in all indoor and outdoor architectural contexts.

The MIMIK / MIMIK FLAT accessory faceplate allows designers to clad the installation in any material they choose, allowing creativity to flourish.

MIMIK 50, the largest and latest version of the series, is a large-sized, high-performance wall pack for any perimeter lighting that is also suitable for the urban context. The essential lines allow total integration in any contemporary setting, and can be combined with the rest of the family.

The MIMIK series, available in ceiling mount (MIMIK 10 / 20), wall effect (MIMIK 10), wall sconce (MIMIK 20 / 30), wall pack (MIMIK 50), bollard (MIMIK 10 POST), provides much more than fittings. FLAT options complete the series, by providing ultra slim versions to the family.





Casa Museo Maffei | Verona | Italy

MIMIK

Design-coordinated ceiling mount (MIMIK CEILING 10 / 20), wall sconce (MIMIK FLAT 10 / 20 / 30), wall effect (MIMIK 10), wall pack (MIMIK 20 / 30 / 50 and bollard (MIMIK 10 POST) series. Fixtures consist of:

Construction

- Die-cast aluminium housing, powder-polyester coated ISO 9227
- MIMIK luminaires are equipped with high-transmittance polycarbonate lenses with different light distributions to meet the most diverse lighting requirements
- Anti-ageing silicone gasket
- Microprismatic, tempered, flat glass diffuser, screen-printed inside for the MIMIK FLAT versions
- Transparent, tempered, flat glass diffuser, screen-printed inside for the MIMIK versions

Installation

- Single (M) and dual (B) emission versions

Listings

- CE
- EAC
- RCM
- ENEC
- Made in Italy

Warranty

- 5-year limited warranty. Complete warranty terms located at www.performanceinlighting.com
- Registered trademark®

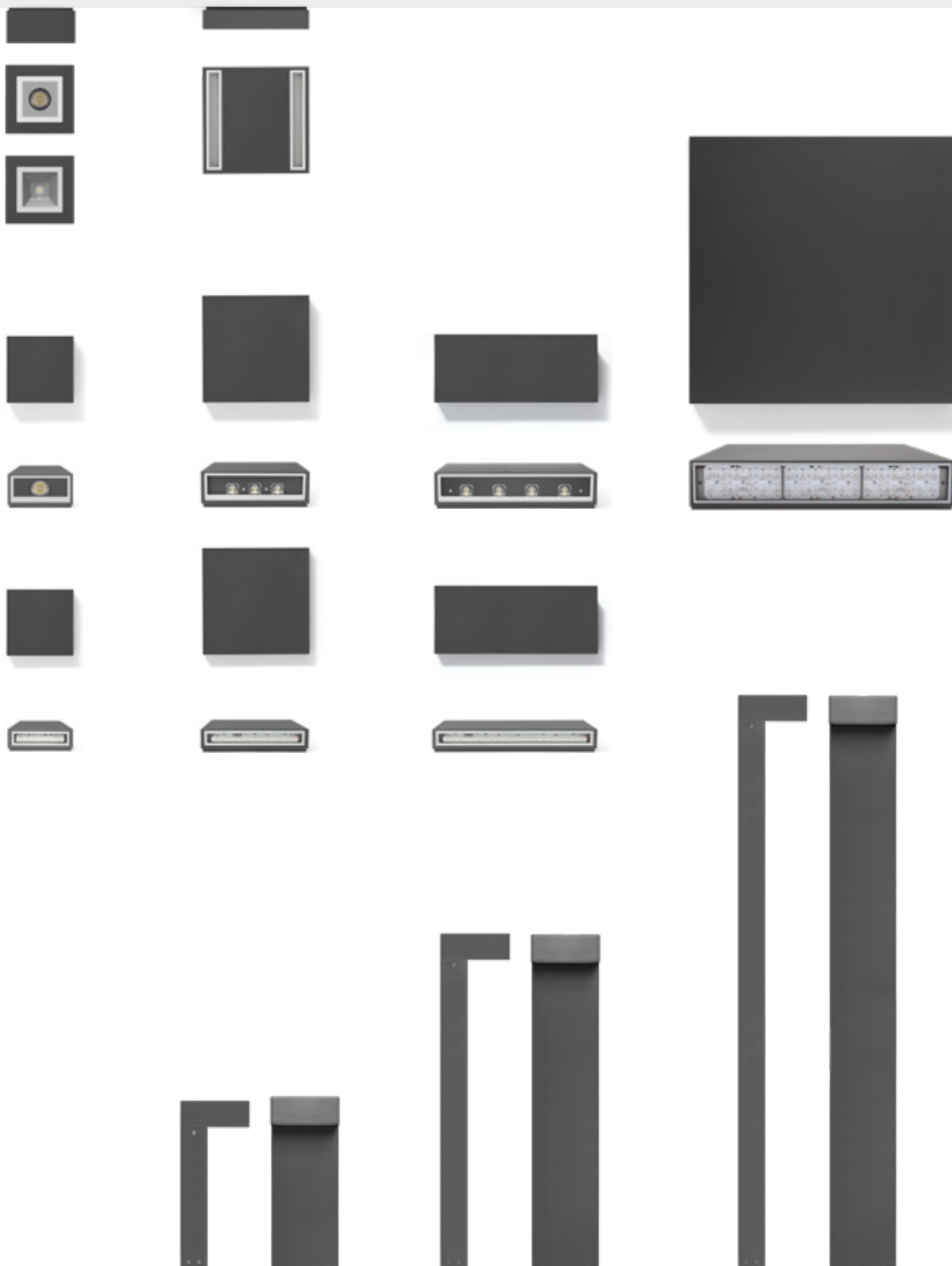



	MIMIK 10 CEILING	MIMIK 20 CEILING	MIMIK 10 POST	
CONSTRUCTION				
IP	IP65	IP65	IP65	
IK	IK06 1J xx3	IK06 1J xx3	IK08 5J xx5	
Dimensions (mm)	L 127 x H 127 x D 65	L 200 x H 200 x D 42	L 130 x H 535 - 635 - 1003 x D 130	
Weight	max 1,09 kg	max 1,70 kg	max 3,01 kg	
Colour	●●○	●●○	●●	
INSTALLATION				
Pre-wired	-	-	-	
Quick	-	-	✓	
Water Stop	-	-	-	
Continuous mounted luminaire	-	-	-	
LED				
Lightsource lumen output	3000 K	1040 lm	3335 lm	1000 lm ÷ 1006 lm
	4000 K	1120 lm	3560 lm	1075 lm ÷ 1076 lm
Luminaire lumen output	3000 K	612 lm ÷ 715 lm	1721 lm	719 lm ÷ 745 lm
	4000 K	704 lm ÷ 822 lm	1778 lm	762 lm ÷ 915 lm
CCT - Correlated Color Temperature	3000 K - 4000 K	3000 K - 4000 K	3000 K - 4000 K	
CRI / SDCM (macadam step)	70/3	80/3	70/3 80/3	
Lifetime	L80B10@60000h	L80B10@84000h	L70B10@35000h L80B10@60000h	
OPTIC				
A/I asymmetric intensive reflector	-	-	A/I	
A/W asymmetric wide reflector	-	-	-	
A60/W asymmetric wide reflector	-	-	-	
C/EW extra wide circle reflector	C/EW	-	-	
CP/T2 pedestrian and cycle reflector type 2	-	-	-	
CP/T3 pedestrian and cycle reflector type 3	-	-	CP/T3	
C/I intensive circle reflector	C/I 20°	-	-	
S/EW symmetric extra wide reflector	-	S/EW	-	
ELECTRICAL				
Wattage	10 W	23.5 W	10 W	
Class	I	I	I	
EEL	-	-	-	
Ta MAX°C luminaire	25°C	40°	35°C	
Ta MIN°C luminaire	-20°C	-20°	-20°C ÷ -25°C	
Dimmable 1-10 V	-	-	-	
Dimmable DALI	-	✓	-	
Emergency	-	-	-	
COSφ ≥ 0,9	✓	✓	✓	

- GR-94 / Metallic grey / Textured
- AN-96 / Anthracite gray / Textured
- WH-87 / White / Textured



MIMIK 10 / 10 FLAT

MIMIK 20 / 20 FLAT

MIMIK 30 / 30 FLAT

MIMIK 50

IP65	IP65	IP65	IP65
IK05 0.70J xx3 IK06 1J xx3	IK06 1J xx3	IK06 1J xx3	IK06 1J xx3
L 127 x H 127 x D 65 - 42	L 200 x H 200 x D 65 - 42 mm	L 300 x H 120 x D 65 - 42	L 500 x H 500 x D 91
max 0,97 kg	max 2,97 kg	max 1,99 kg	max 10,13 kg
● ● ○	○ ● ●	● ● ○	●
-	-	-	-
-	-	-	-
-	-	-	-
-	-	-	✓
561 lm ÷ 1140 lm	1653 lm ÷ 3306 lm	2644 lm ÷ 4160 lm	6630 lm ÷ 17260 lm
593 lm ÷ 1357 lm	1710 lm ÷ 3420 lm	2736 lm ÷ 4480 lm	6920 lm ÷ 18000 lm
314 lm ÷ 880 lm	958 lm ÷ 2273 lm	1506 lm ÷ 2558 lm	4299 lm ÷ 11124 lm
358 lm ÷ 925 lm	1041 lm ÷ 2309 lm	1597 lm ÷ 2755 lm	4573 lm ÷ 12601 lm
3000 K - 4000 K	3000 K - 4000 K	3000 K - 4000 K	3000 K - 4000 K
70/3 80/3	70/3 80/3	70/3 80/3	80/3
L80B10@60000h	L80B10@60000h	L80B10@60000h	L80B10@71000h
-	-	-	-
A/W	A/W	A/W	-
-	A60/W	A60/W	A60/W
-	-	-	-
-	CP/T2	CP/T2	CP/T2
CP/T3	CP/T3	CP/T3	-
C/I 20°	-	-	-
5 W - 10 W	13,5 W - 16,5 W - 21 W - 24 W - 26 W	20 W - 30 W	39 W - 53 W
I	I	I	I
-	-	-	-
25°C ÷ 30°C	25°C ÷ 45°C	25°C ÷ 35°C	40°C ÷ 50°C
-20°C ÷ -10°C	-20°C ÷ 0°C	-20°C	-25°C ÷ -40°C
-	-	-	-
-	-	-	✓
-	1 h / 3 h	-	3 h
✓	✓	✓	✓

MIMIK 10 / 20 CEILING



Polyester powder coated die-cast aluminium housing.

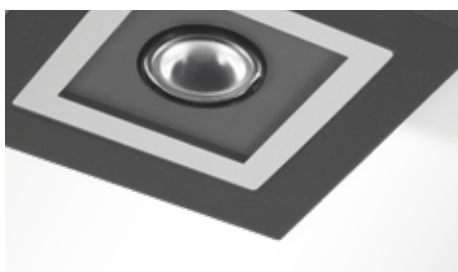

Flat tempered transparent, and internally etched glass diffuser for the MIMIK 10 CEILING versions.

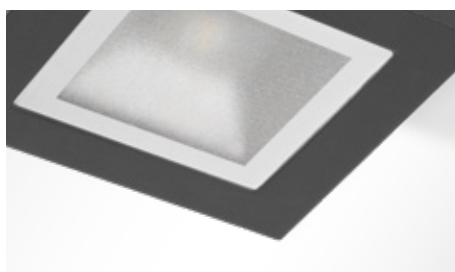

Flat, microprismatic tempered glass diffuser, screen printed on the inner surface for MIMIK 10 CEILING TECH.

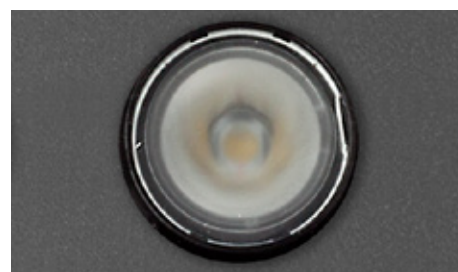

Equipped with high-transmittance polycarbonate lenses with different light distributions to meet the most diverse lighting requirements.

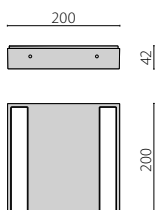
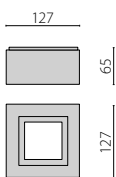

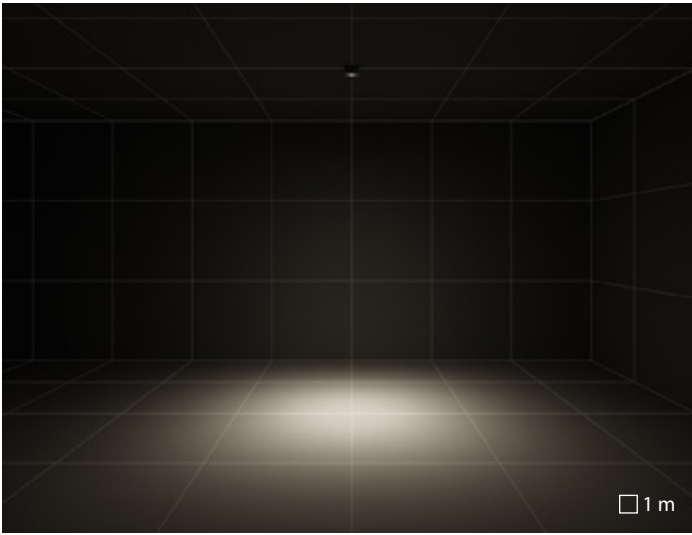

MIMIK 10 CEILING | C/1 intensive circle reflector

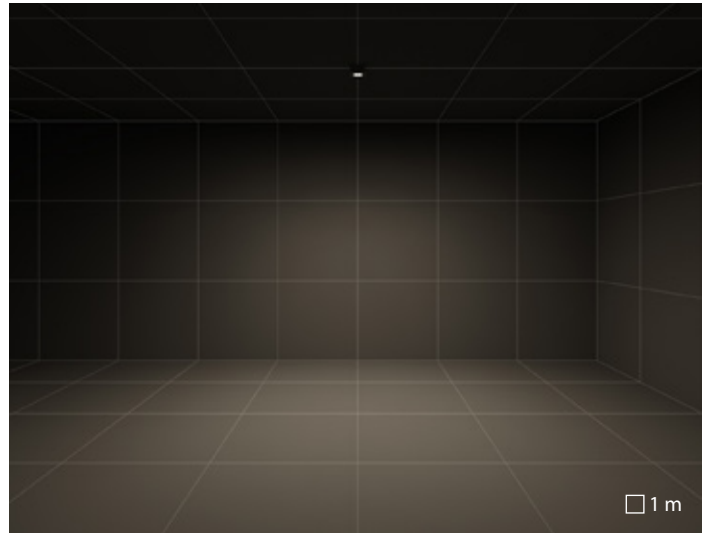

MIMIK 10 CEILING | C/EW extra wide circle reflector

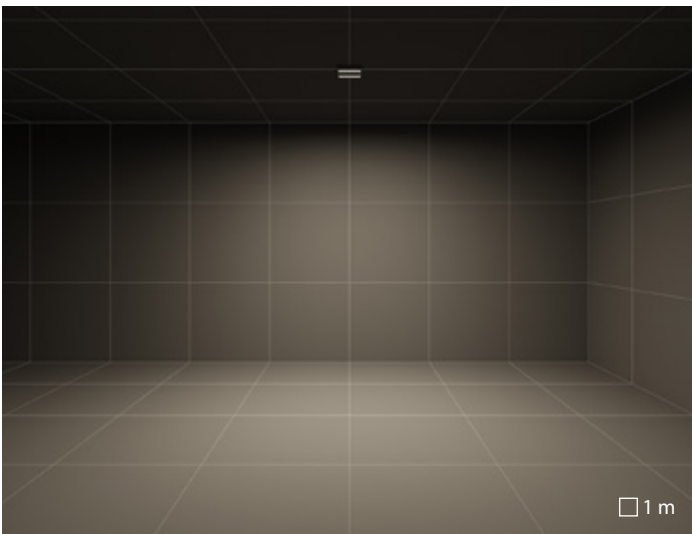

MIMIK 20 CEILING | S/EW symmetric extra wide reflector

MIMIK 10 / 20 / 30



The frame which is available as an accessory, allows the panel to be installed on the luminaire front. The panel can be plastered to match the finish of the wall on which it is to be installed.



Flat, transparent, tempered glass diffuser, screen printed on the inner surface for MIMIK series.



Polyester powder coated die-cast aluminium housing.



Frame for customizing the panel available for MIMIK 20 / 30 (to be ordered separately).

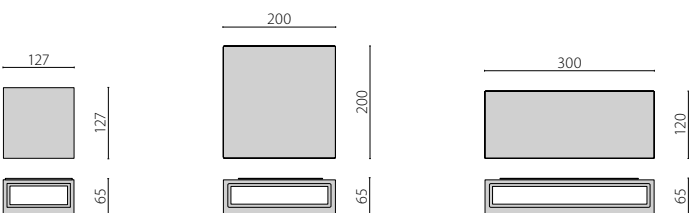

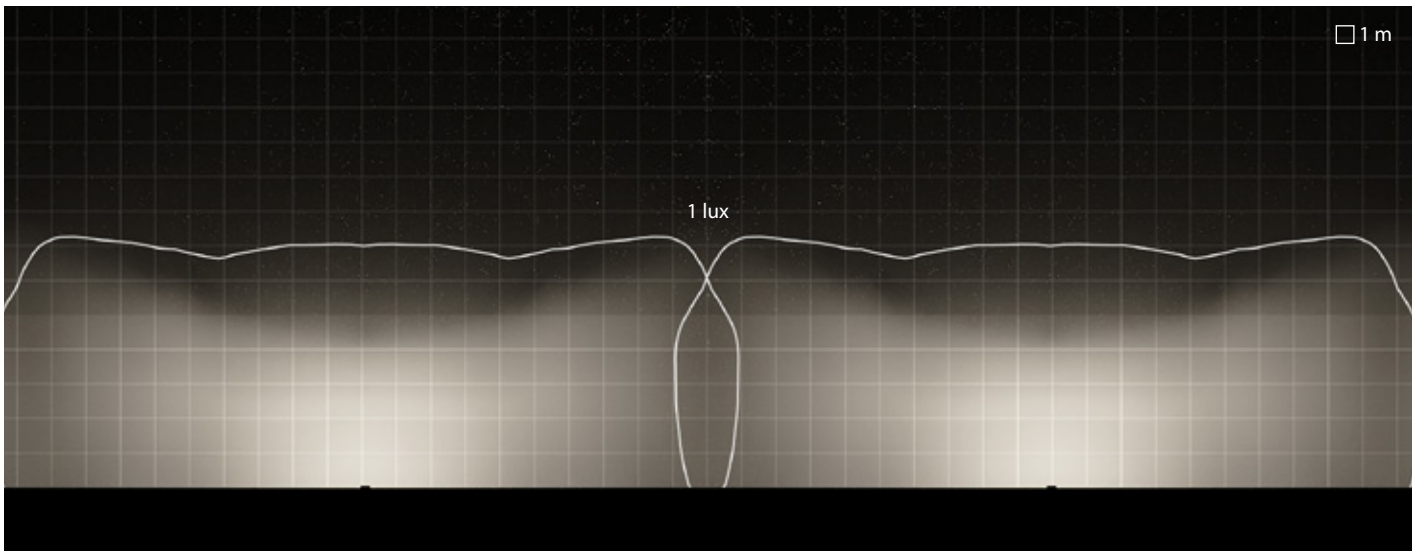

MIMIK 30 M | CP/T3 pedestrian and cycle reflector type 3

Luminaire spacing = 20m
 Path depth = 5m
 Mounting height = 3m

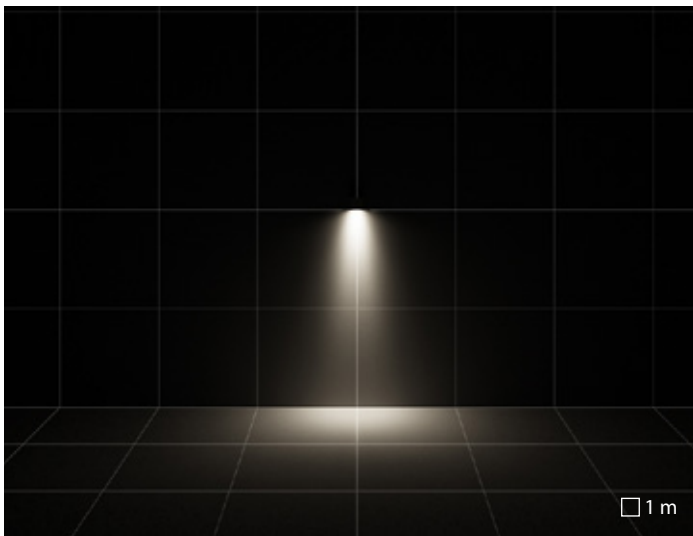

MIMIK 10 M | C/I intensive circle reflector

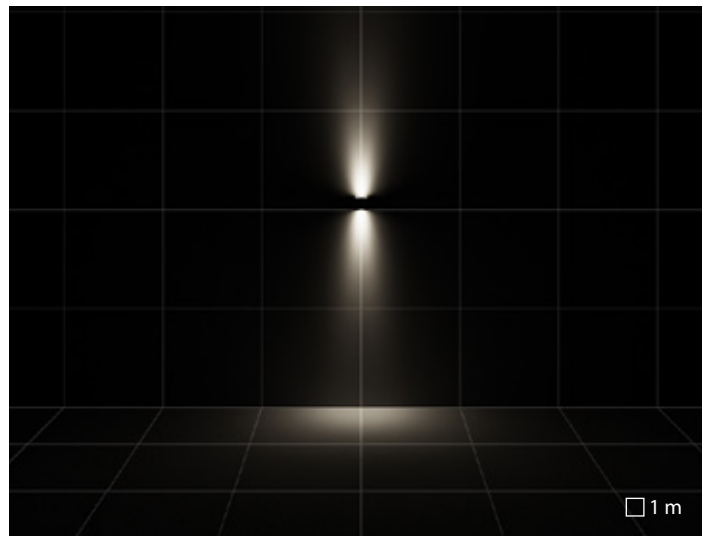

MIMIK 10 B | C/I intensive circle reflector

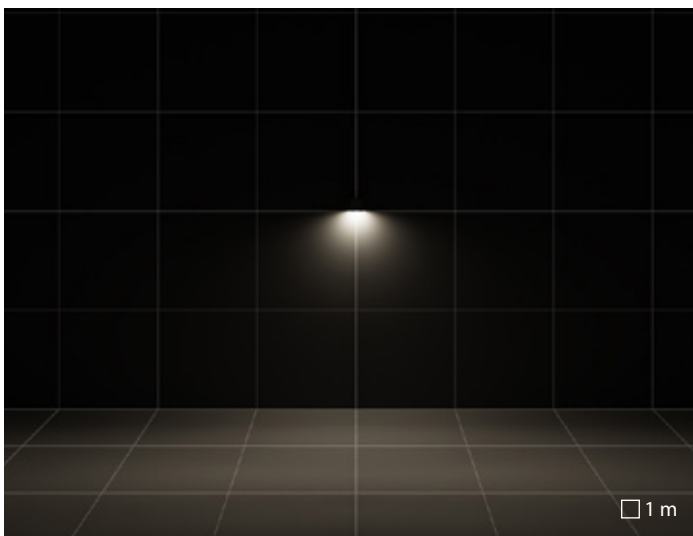

MIMIK 10 M | CP/T3 pedestrian and cycle reflector type 3

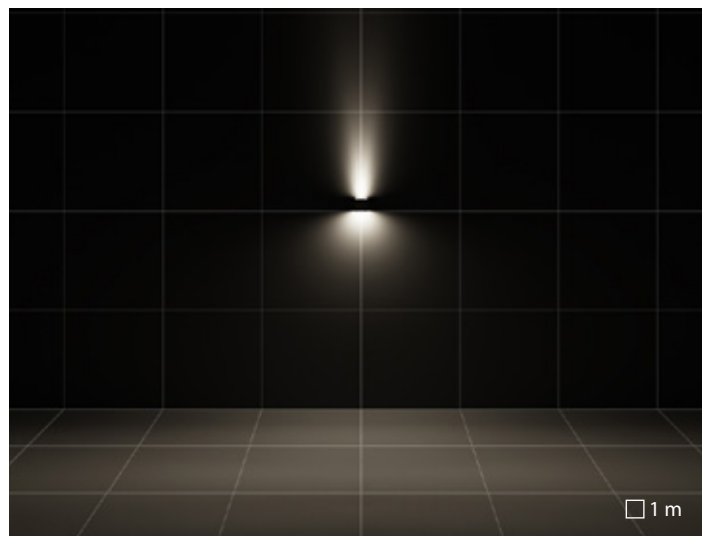

MIMIK 10 M | CP/T3 pedestrian and cycle reflector type 3 + C/I intensive circle reflector

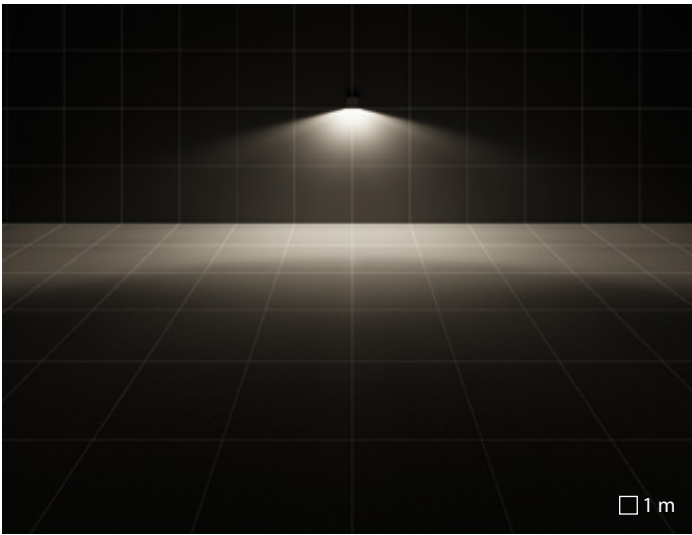

MIMIK 20 | CP/T2 pedestrian and cycle reflector type 2

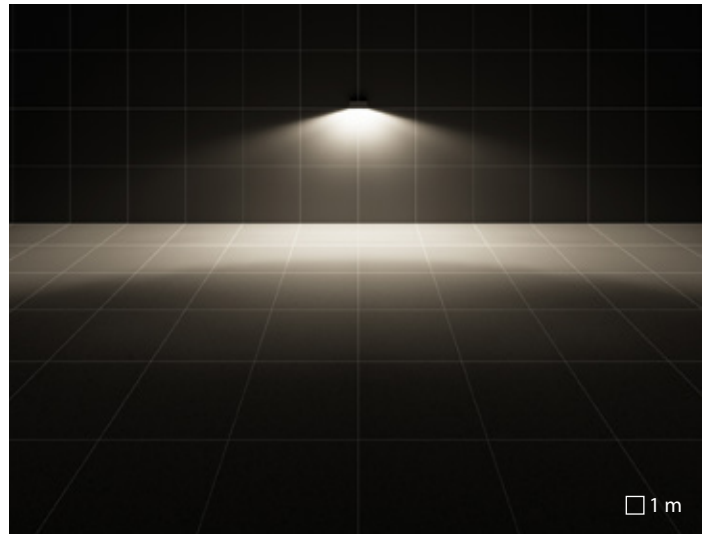

MIMIK 30 | CP/T2 pedestrian and cycle reflector type 2

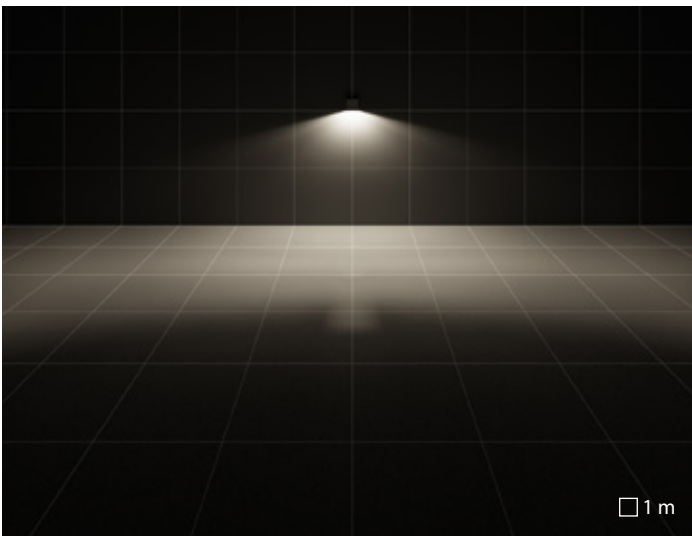

MIMIK 20 | CP/T3 pedestrian and cycle reflector type 3

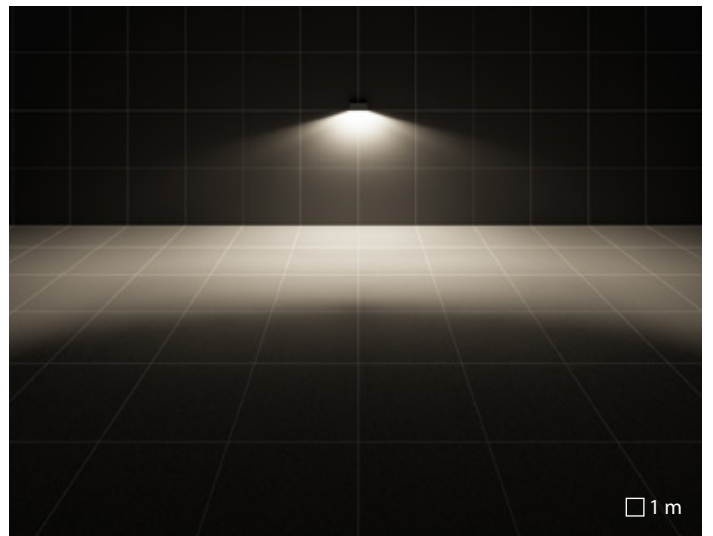

MIMIK 30 | CP/T3 pedestrian and cycle reflector type 3

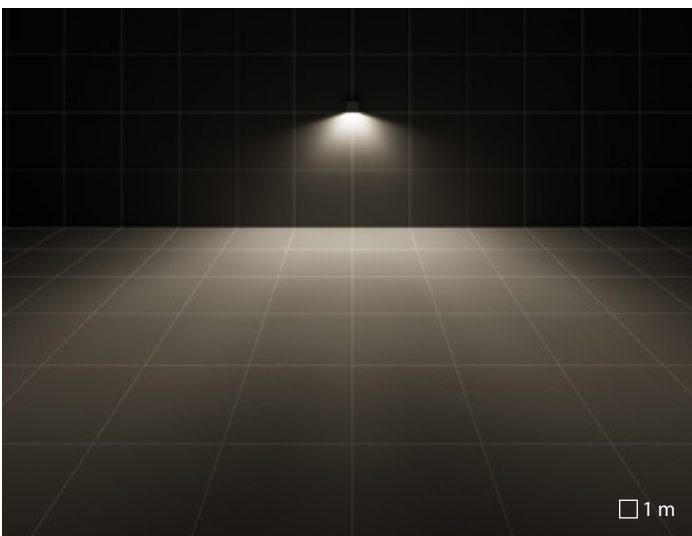

MIMIK 20 | A60/W asymmetric wide reflector

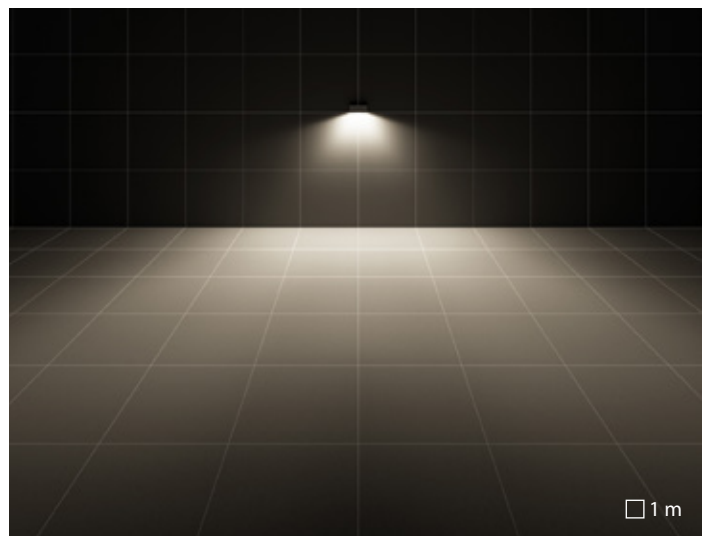

MIMIK 30 | A60/W asymmetric wide reflector



Jeruzalem Blok M | Amsterdam | Netherlands

MIMIK 10 / 20 / 30 FLAT



The frame which is available as an accessory, allows the panel to be installed on the luminaire front. The panel can be plastered to match the finish of the wall on which it is to be installed.



Flat, microprismatic tempered glass diffuser, screen printed on the inner surface for MIMIK FLAT series.

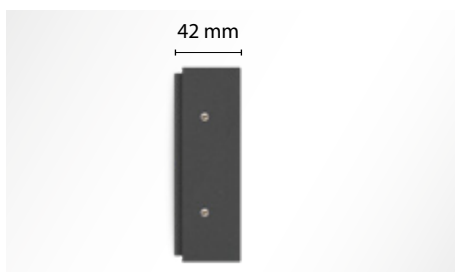

Polyester powder coated die-cast aluminium housing.



Frame for customizing the panel available for MIMIK 20 / 30 (to be ordered separately).

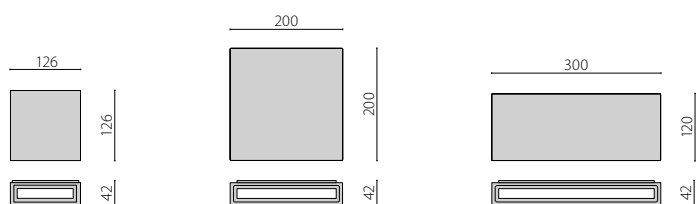

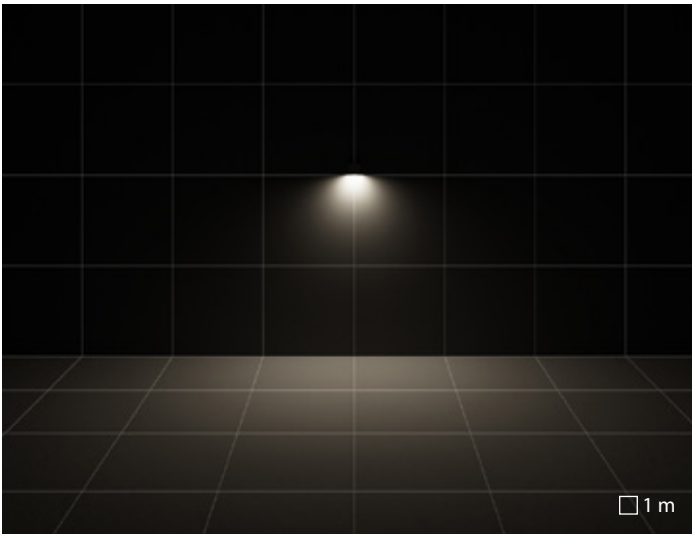

MIMIK 10 FLAT M | A/W asymmetric wide reflector

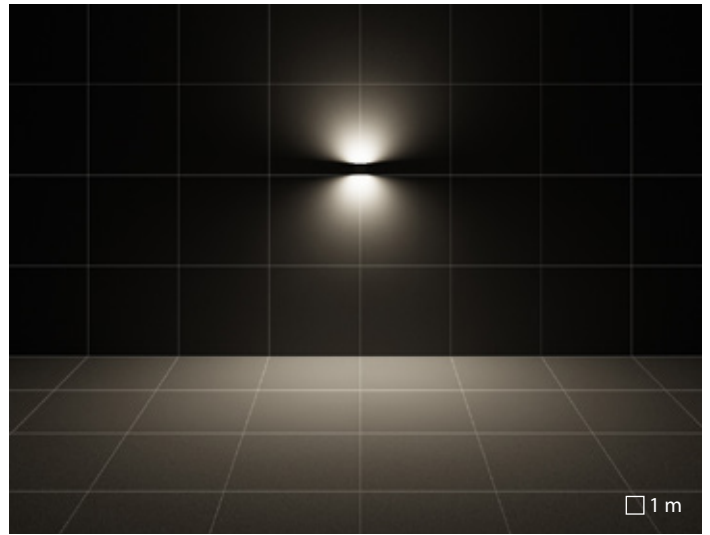

MIMIK 10 FLAT B | A/W asymmetric wide reflector

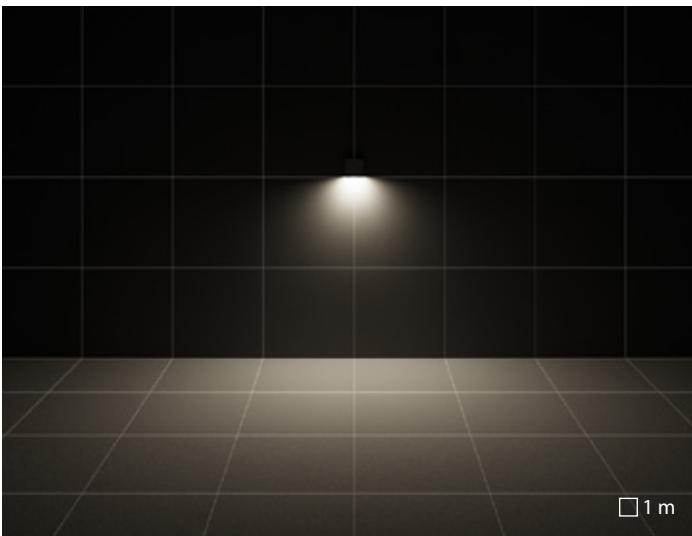

MIMIK 20 FLAT M | A/W asymmetric wide reflector

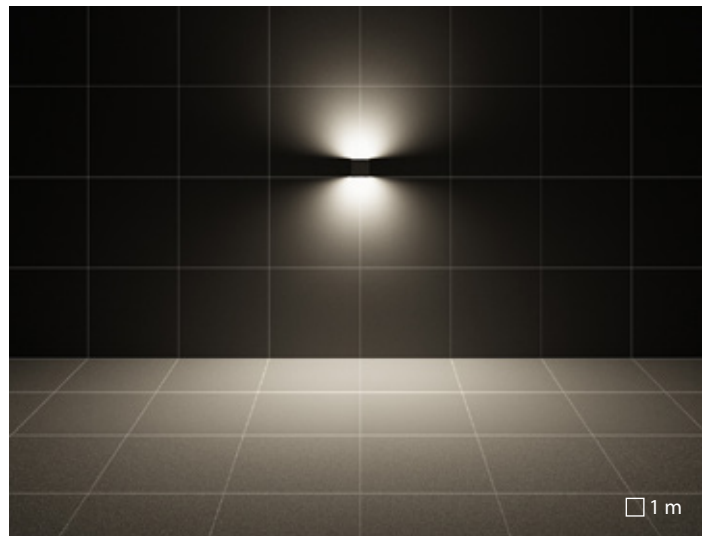

MIMIK 20 FLAT B | A/W asymmetric wide reflector

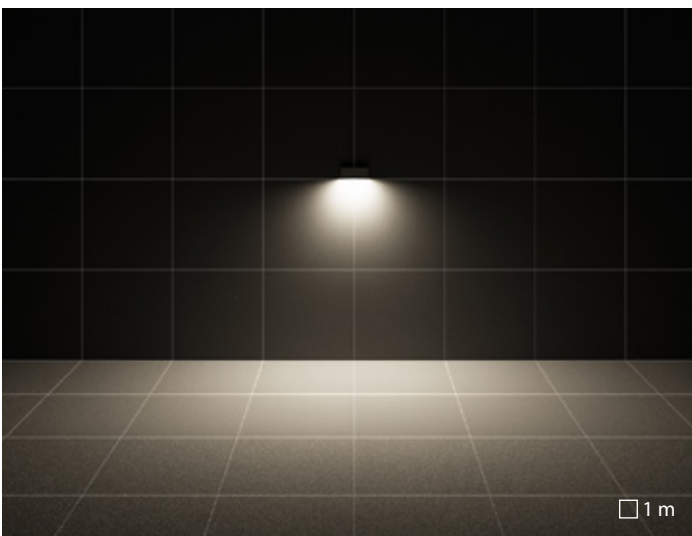

MIMIK 30 FLAT M | A/W asymmetric wide reflector





Conference hall - Batteria di Scarpa | Verona | Italy

MIMIK 50



High-transparency polycarbonate lenses for best light transmission.



Extra-clear flat tempered glass diffuser internally screen-printed.



Frame for customizing the panel available for MIMIK 50 (to be ordered separately).



The fitting is suitable for through-wiring.

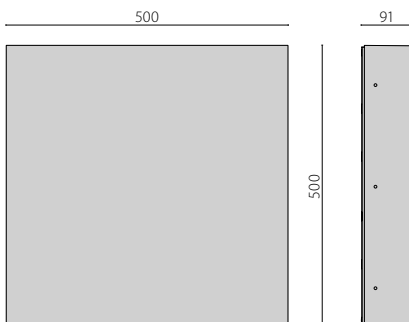

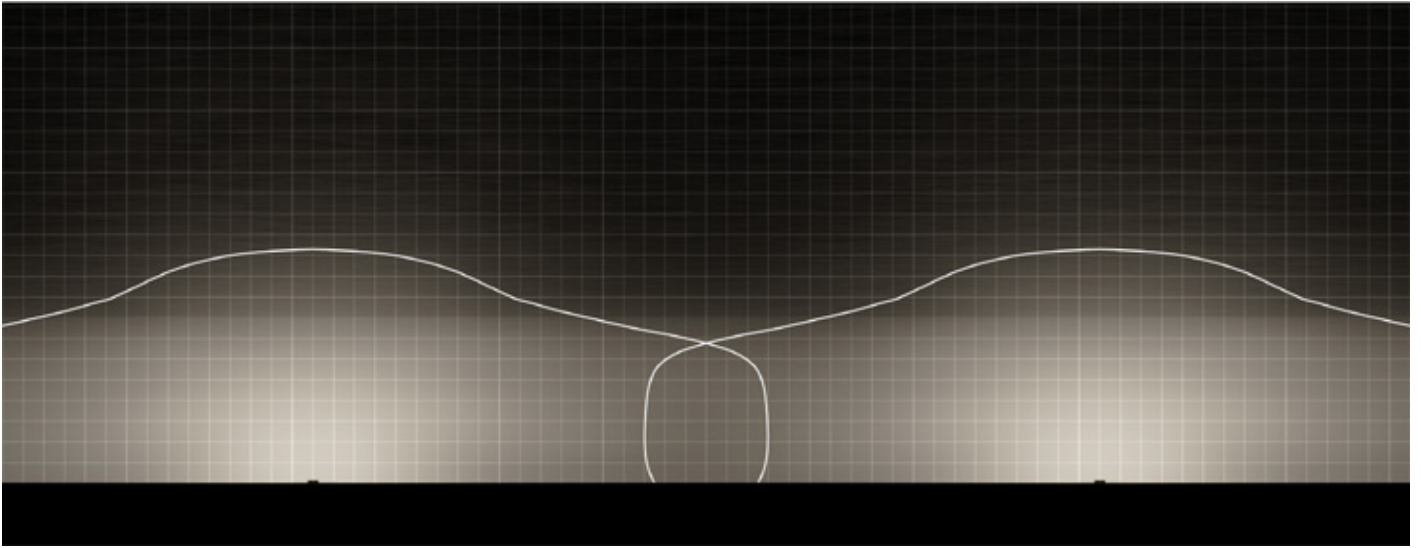

MIMIK 50 M | CP/T2 pedestrian and cycle reflector type 2

Luminaire spacing = 38m
 Path depth = 8m
 Mounting height = 6m

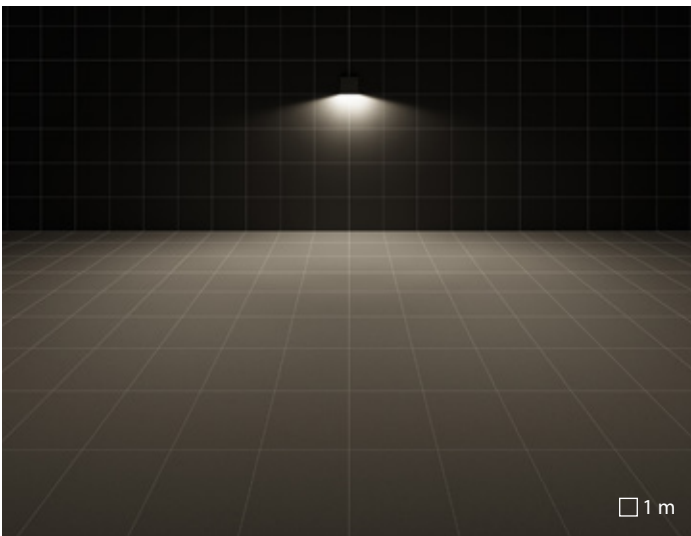

MIMIK 50 M | A60/W asymmetric wide reflector

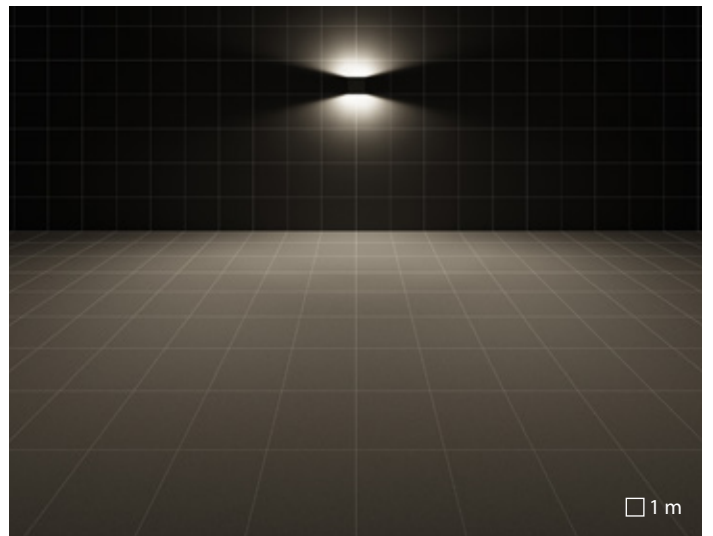

MIMIK 50 B | A60/W asymmetric wide reflector

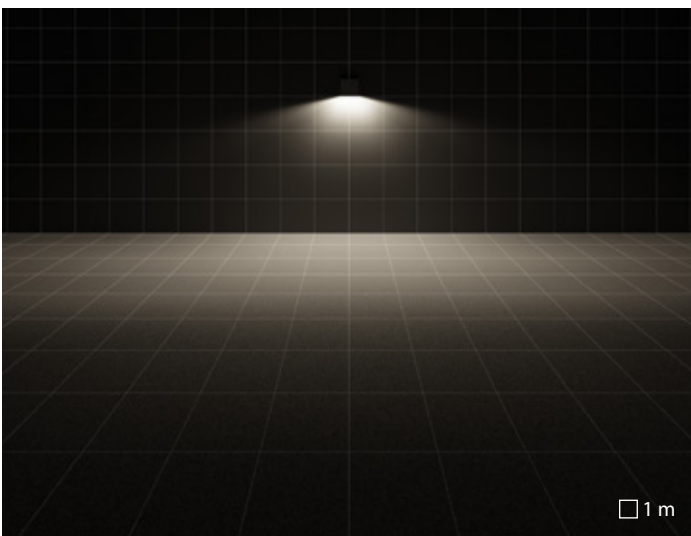

MIMIK 50 M | CP/T2 pedestrian and cycle reflector type 2

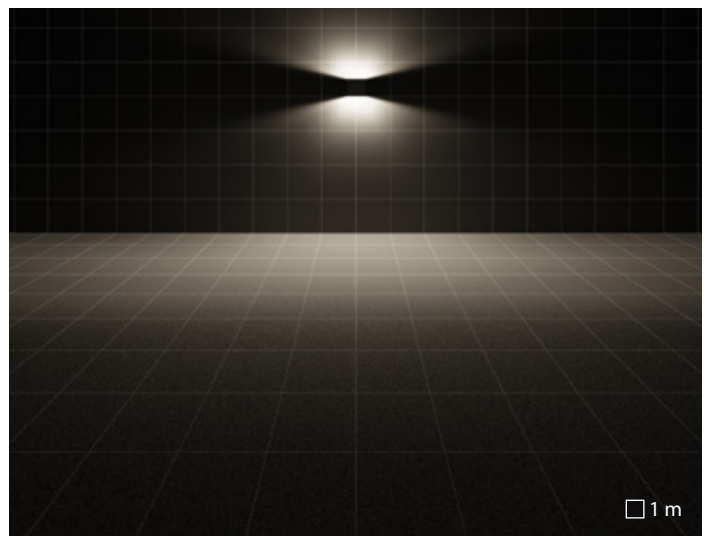

MIMIK 50 B | CP/T2 pedestrian and cycle reflector type 2

MIMIK 10 POST



Full cut-off.



CP versions feature asymmetric light distribution suitable for bicycle and pedestrian pathways.



Tempered glass diffuser, printed.



Equipped with high-transmittance polycarbonate lenses with different light distributions to meet the most diverse lighting requirements.



External electrical connection with sealed plug-socket QUICK, complete with cable.

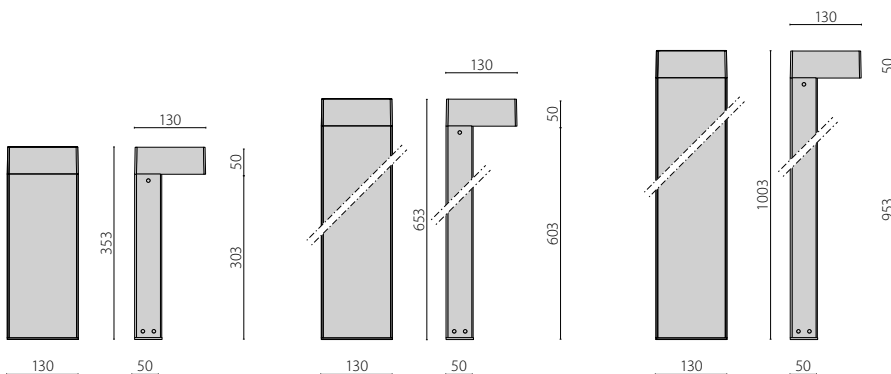

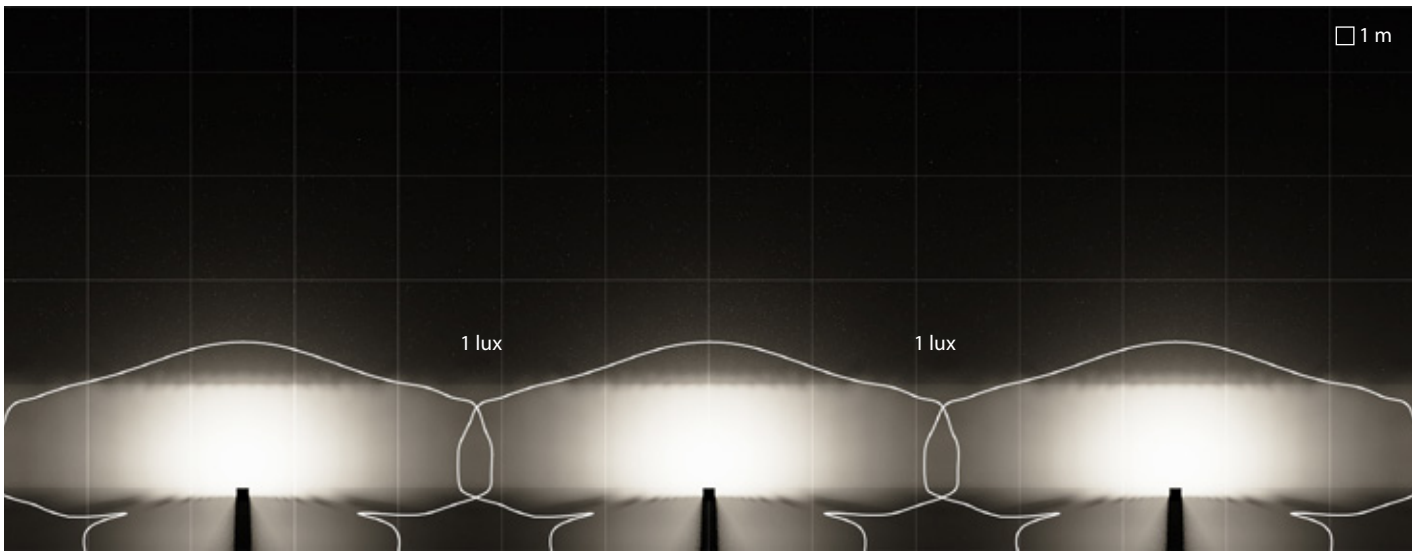

MIMIK 10 POST 600 | A/I asymmetric intensive reflector

Luminaire spacing = 4.5m
 Path depth = 1m
 Mounting height = 0m

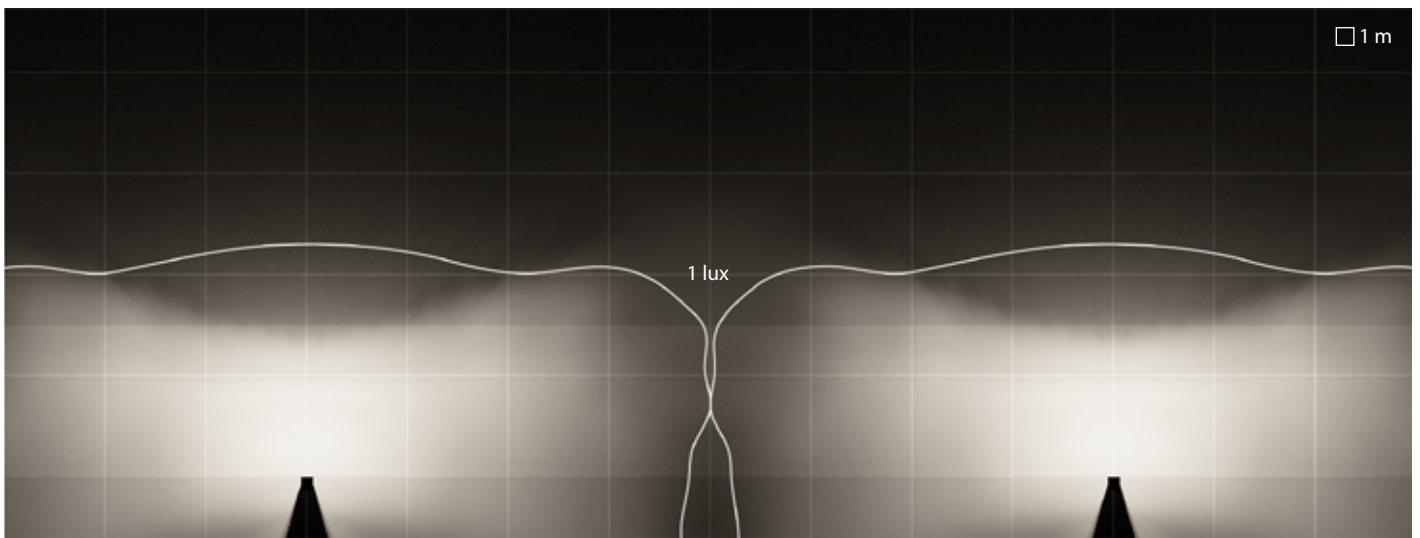

MIMIK 10 POST 1000 | CP/T3 pedestrian and cycle reflector type 3

Luminaire spacing = 8m
 Path depth = 1.5m
 Mounting height = 0m

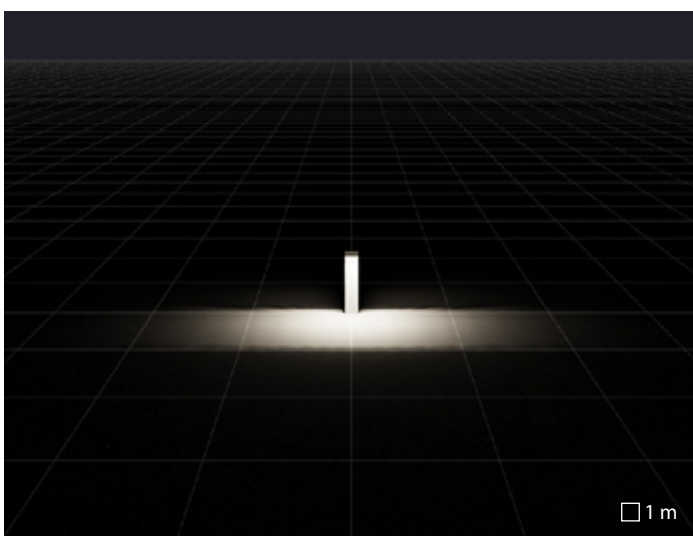

MIMIK 10 POST 600 | A/I asymmetric intensive reflector

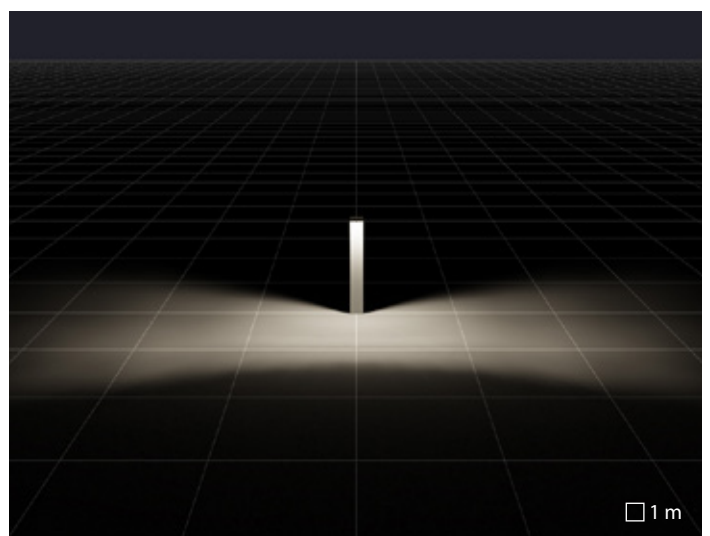

MIMIK 10 POST 1000 | CP/T3 pedestrian and cycle reflector type 3

Q-LIGHT

A sharp edge family

Artificial light plays an essential role in the environment during nighttime: it provides orientation, transmits mood and emotion, draws attention.

Pairing clean architecture with robust technical engineering; Q-light bridges the gap between simplistic beauty and sophisticated performance. Look to Q-light as a basis for your lighting concept.

Q-LIGHT is indicated for walkways, environmental obstacles, boundaries, decoration, and safety lighting. It is designed for low-consumption LED light sources.





Q-LIGHT

Landscaping LED bollard, comprising:

Construction

- Die-cast aluminium housing and fixing plate for in-ground installation, painted
- Die-cast aluminium housing, powder-polyester coated ISO 9227
- Extruded aluminium pole powder-polyester coated ISO 9227
- Extra pure polished aluminium reflector
- Clear UV-stabilised and impact-resistant technopolymer diffuser
- Stainless steel fixing screws and rods

Electrical

- Built-in driver

Installation

- QUICK versions are supplied complete with IP rated connection box suitable for through wiring for Ø 5 mm to Ø 13 mm cables
- Die-cast aluminium housing complete with two PG11 cable glands suitable for through wiring of Ø 5 mm to Ø 10 mm cables
- Base plate included

Listings

- CE
- EAC
- RCM
- Made in Italy

Warranty

- 5-year limited warranty. Complete warranty terms located at www.performanceinlighting.com





Q-LIGHT

CONSTRUCTION		
IP		IP65
IK		IK05 0.70J xx3
Dimensions (mm)		L 118 x H 683 x D 118
Weight		max 4,97 kg
Colour		● ●
INSTALLATION		
Pre-wired		-
Quick		✓
Water Stop		-
Continuous mounted luminaire		✓
LED		
Lightsource lumen output	3000 K	1944 lm
	4000 K	2088 lm
Luminaire lumen output	3000 K	1024 lm
	4000 K	1151 lm
CCT - Correlated Color Temperature		3000 K - 4000 K
CRI / SDCM (macadam step)		80/3
Lifetime		L90B10@36000h
OPTIC		
S/W symmetric wide reflector		S/W
ELECTRICAL		
Wattage		14 W
Class		I
EEl		-
Ta MAX°C luminaire		35°C
Ta MIN°C luminaire		-20°C
Dimmable 1-10 V		-
Dimmable DALI		-
Emergency		-
COSφ ≥ 0,9		✓

- GR-94 / Metallic grey / Textured
- AN-96 / Anthracite gray / Textured



Q-LIGHT



The polycarbonate diffuser with high impact strength is UV-stabilised, therefore prolonged exposure to sunlight does not change the colour or transparency.

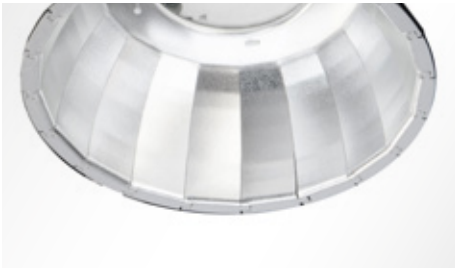

99,85% high performance anodised aluminium circular reflectors



New vandalproof baseplate included.

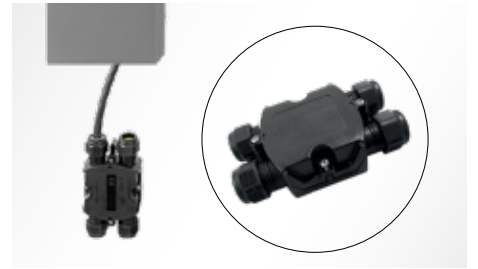

Pre-wired factory sealed cable for external electrical connection included.

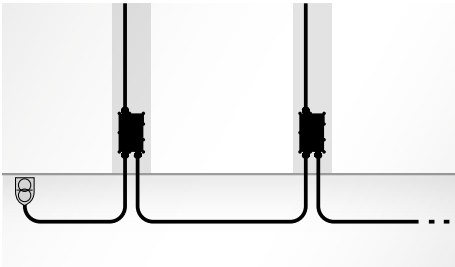

The fitting is suitable for through-wiring.

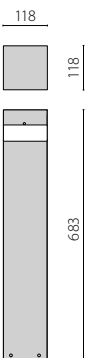

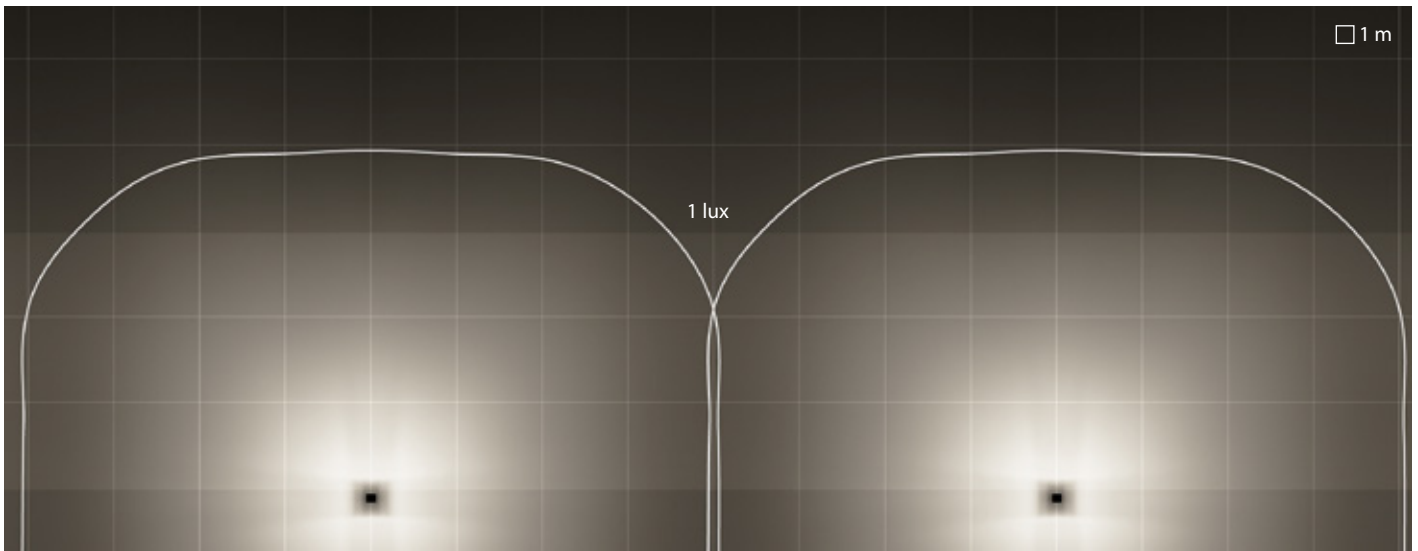

S/W symmetric wide reflector

Luminaire spacing = 8m
 Path depth = 3m
 Mounting height = 0m

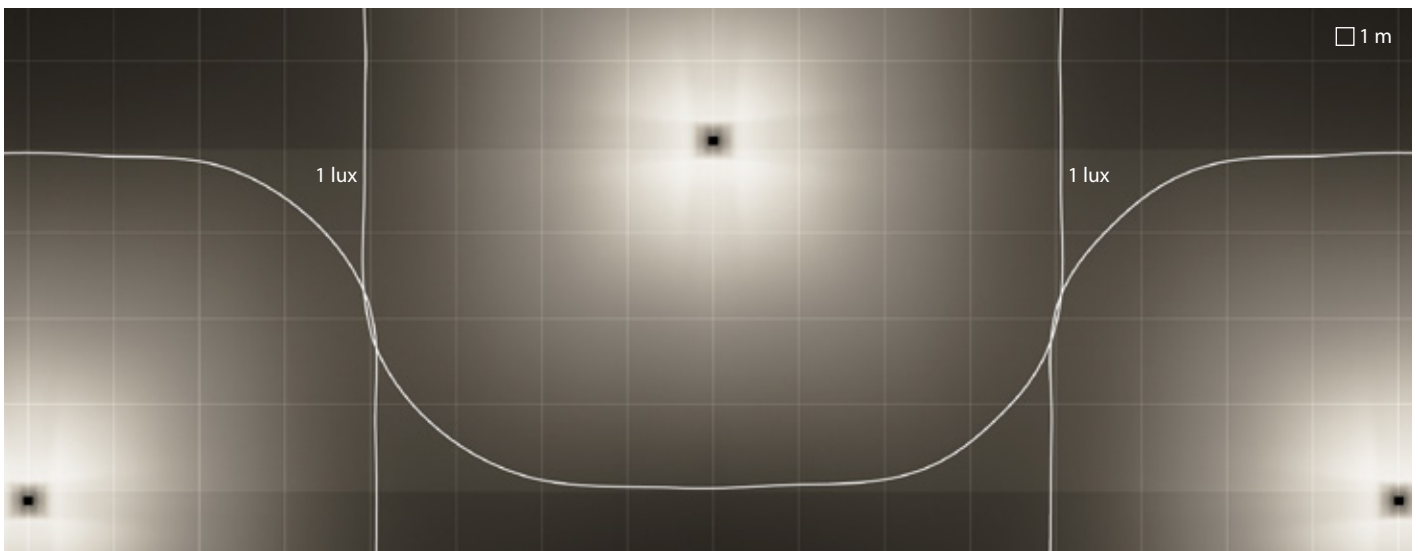

S/W symmetric wide reflector

Luminaire spacing = 8m
 Path depth = 4m
 Mounting height = 0m

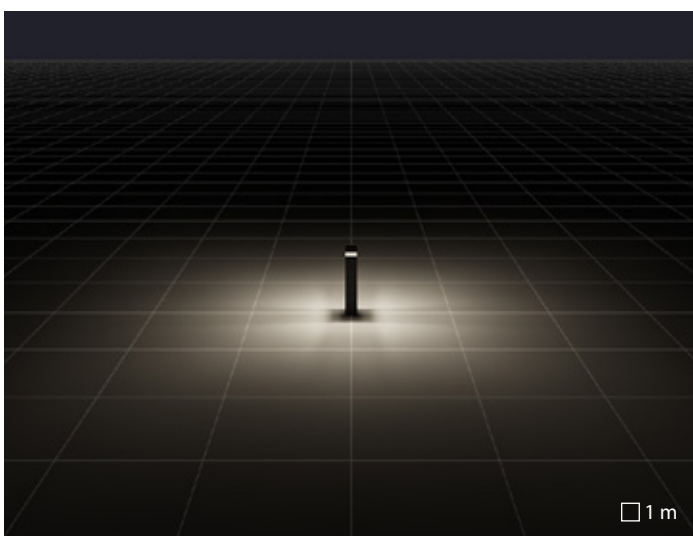

S/W symmetric wide reflector

KHA

design Silvia Paola Pennacchio

The light caresses the ground

KHA and KHA SLIM are contemporary high-performance bollards and slim light columns, combining style with a robust design and manufactured in high-quality materials and finishing. The KHA SLIM luminaires provide functional and dramatic effect lighting with aesthetics suitable for entrances, paths, walkways, courtyards, gardens, public areas, and security lighting. The KHA bollard family offers contemporary aesthetics with zero upward light pollution options, suitable for private residential and open space lighting, parks, gardens, and commercial complexes.

Different models, light distributions and heights within one and only design, create the unique uniformity of your projects.





Turner Contemporary | Margate - Kent | UK

KHA

design Silvia Paola Pennacchio

Design coordinated slim area / site lighting column (KHA SLIM 220) and bollard (KHA 5 / 9 - KHA SLIM 31 / 91) series. Fixtures consist of:

Construction

- Housing and cap made of AISI 316 electropolished stainless steel or powder coated aluminium, depending on versions
- Inner aluminium extruded LED heat sink
- Technopolymer electrical gear support
- Extra pure polished aluminium reflector
- Anti-ageing silicone gasket
- UV stabilised transparent polycarbonate diffuser
- Stainless steel external screws

Installation

- Die-cast aluminium floor mount base polyester, powder coated after chemical conversion treatment of the surface
- KHA SLIM 220 floor installation can be done through a galvanised steel plinth to be directly buried in concrete or with a stainless steel base to be fastened to the floor with anchor bolts (included)
- Fixing rods are available as accessories for installation on cement

Listings

- CE
- EAC
- RCM
- Made in Italy

Warranty

- 5-year limited warranty. Complete warranty terms located at www.performanceinlighting.com

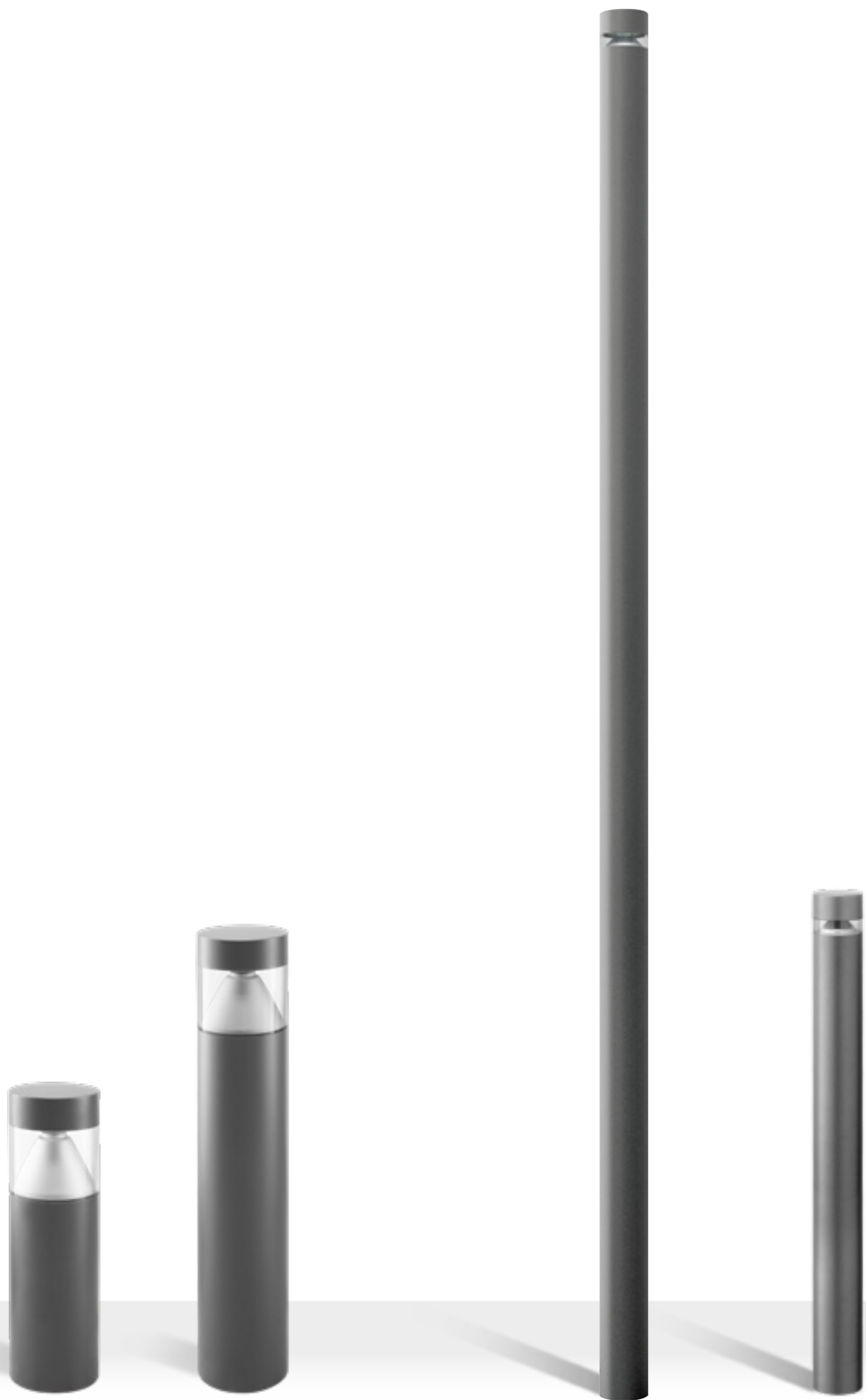



KHA 5 / 9



KHA SLIM 93 / 220

CONSTRUCTION			
IP		IP66	IP66
IK		IK10 24J xx9	IK09 10J xx7
Dimensions (mm)		155 x H 550 - 900	Ø 90 x H 930 - 2200
Weight		max 8,82 kg	max 7,72 kg
Colour		●●●	●●●
INSTALLATION			
Pre-wired		-	-
Quick		-	-
Water Stop		-	-
Continuous mounted luminaire		✓	-
LED			
Lightsource lumen output	3000 K	2370 lm	1677 lm
	4000 K	2448 lm	1733 lm
	5000 K	2684 lm	1899 lm
Luminaire lumen output	3000 K	1182 lm	483 lm
	4000 K	1357 lm	546 lm
	5000 K	1380 lm	592 lm
CCT - Correlated Color Temperature		3000 K - 4000 K - 5000 K	3000 K - 4000 K - 5000 K
CRI / SDCM (macadam step)		70/3	70/3
		80/3	80/3
Lifetime		L80B10@50000h	L80B10@50000h
OPTIC			
C/EW extra wide circle reflector		C/EW	C/EW
ELECTRICAL			
Wattage		19 W - 1x35 W - 1x70 W - 1x26/32/42 W	13 W - 1x10 W - 1x20 W
Class		I - II	II
EEl		A2	A3
Ta MAX°C luminaire		50°C ÷ 30°C	35°C ÷ 25°C
Ta MIN°C luminaire		-15°C ÷ -20°C	-10°C ÷ -20°C
Dimmable 1-10 V		-	✓
Dimmable DALI		-	-
Emergency		-	-
COSφ ≥ 0,9		✓	✓

- AN-96 / Anthracite gray / Textured
- BK-81 / Black / Textured
- INOX / Stainless steel / Matt



"Città di Lombardia" square | Milan | Italy



Housing and cap made of AISI 316 electropolished stainless steel or powder coated aluminium, depending on versions.



Extra pure polished aluminium reflectors.



Die-cast aluminium floor mount base polyester, powder coated after chemical conversion treatment of the surface.



Electrical connection with quick disconnect connector in PA66 without halogens and phosphorus with silver-plated copper contacts, for cables $\varnothing 9 - \varnothing 14$ mm.

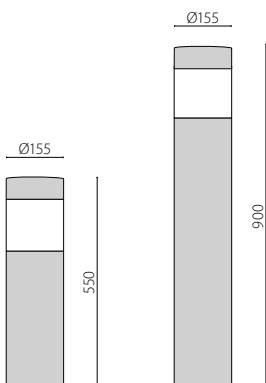

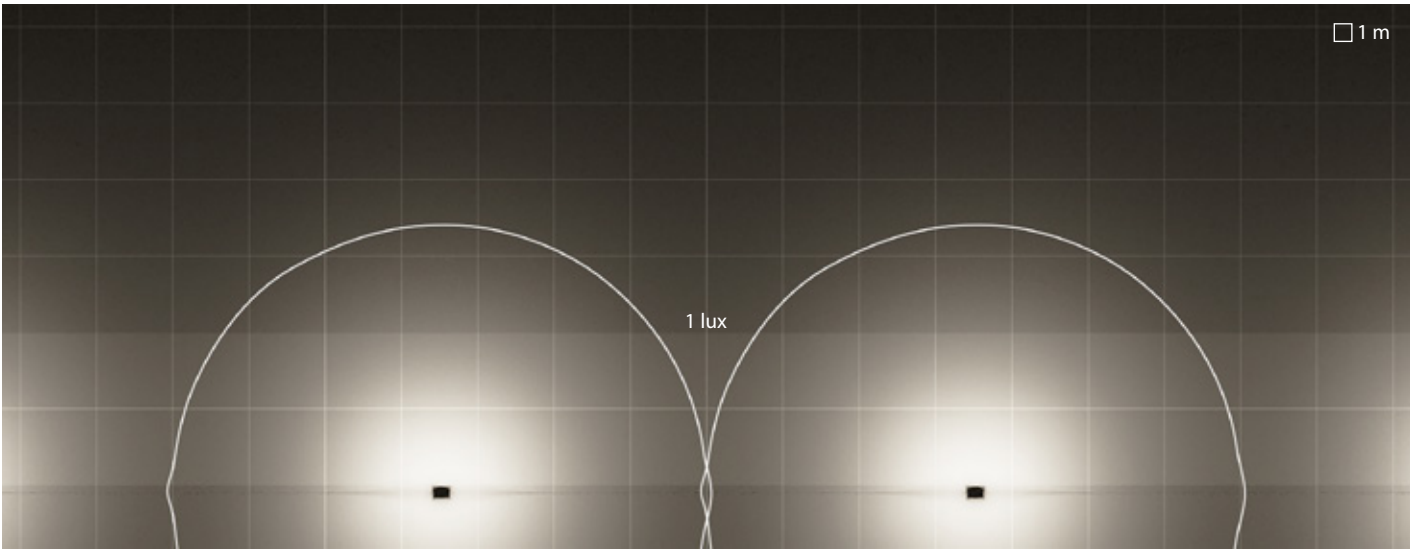

KHA 5 | C/EW extra wide circle reflector

Luminaire spacing = 7m
 Path depth = 2m
 Mounting height = 0m

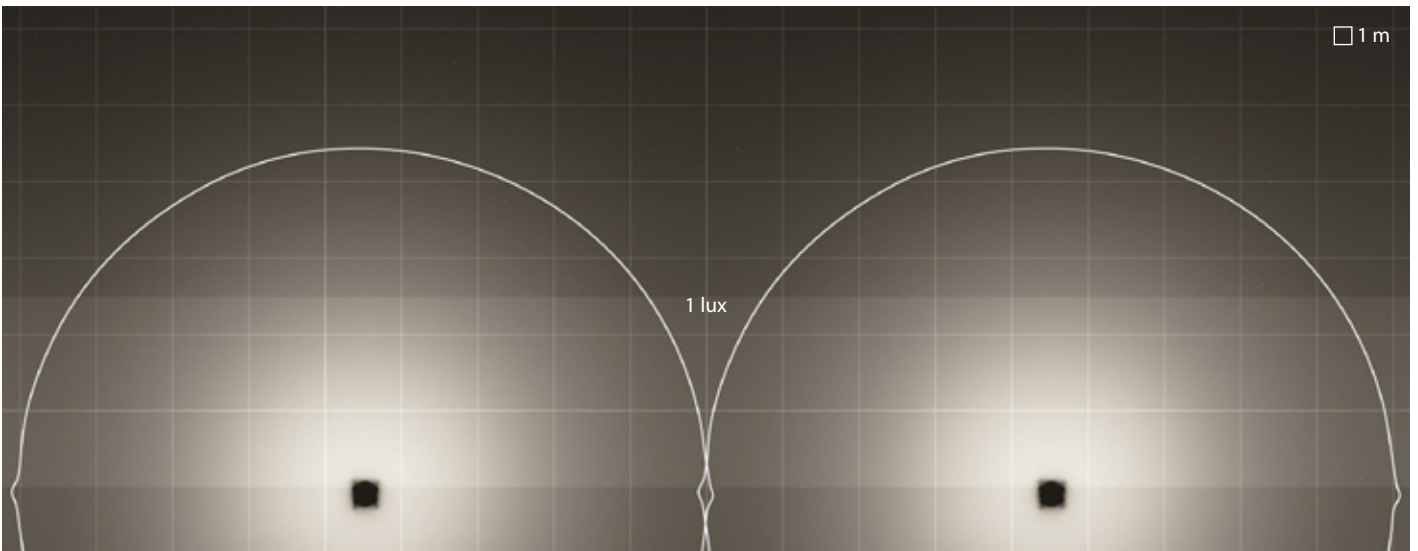

KHA 9 | C/EW extra wide circle reflector

Luminaire spacing = 9m
 Path depth = 2.5m
 Mounting height = 0m

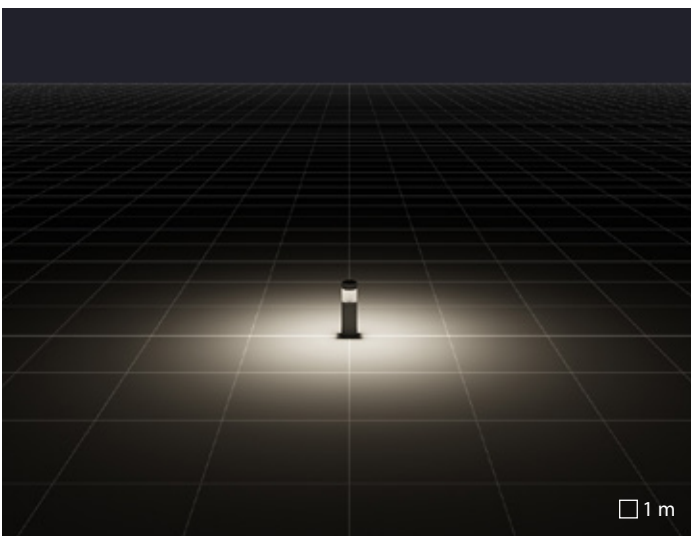

KHA 5 | C/EW extra wide circle reflector

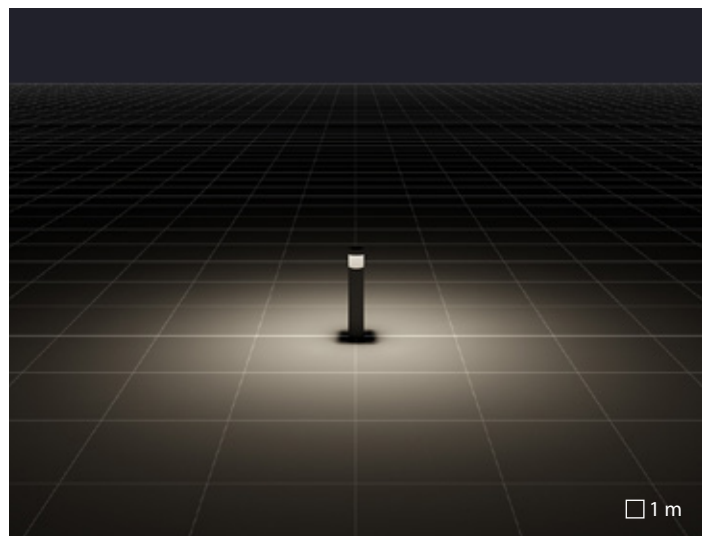

KHA 9 | C/EW extra wide circle reflector

KHA SLIM 93 / 220



Housing and cap made of AISI 316 electropolished stainless steel or powder coated aluminium, depending on versions.



Extra pure polished aluminium reflectors.



Die-cast aluminium floor mount base polyester, powder coated after chemical conversion treatment of the surface.



Electrical connection with quick disconnect connector in PA66 without halogens and phosphorus with silver-plated copper contacts, for cables $\varnothing 9 - \varnothing 14$ mm.



KHA SLIM 220 floor installation can be done through a galvanised steel plinth to be directly buried in concrete or with a stainless steel base to be fastened to the floor with anchor bolts (included).



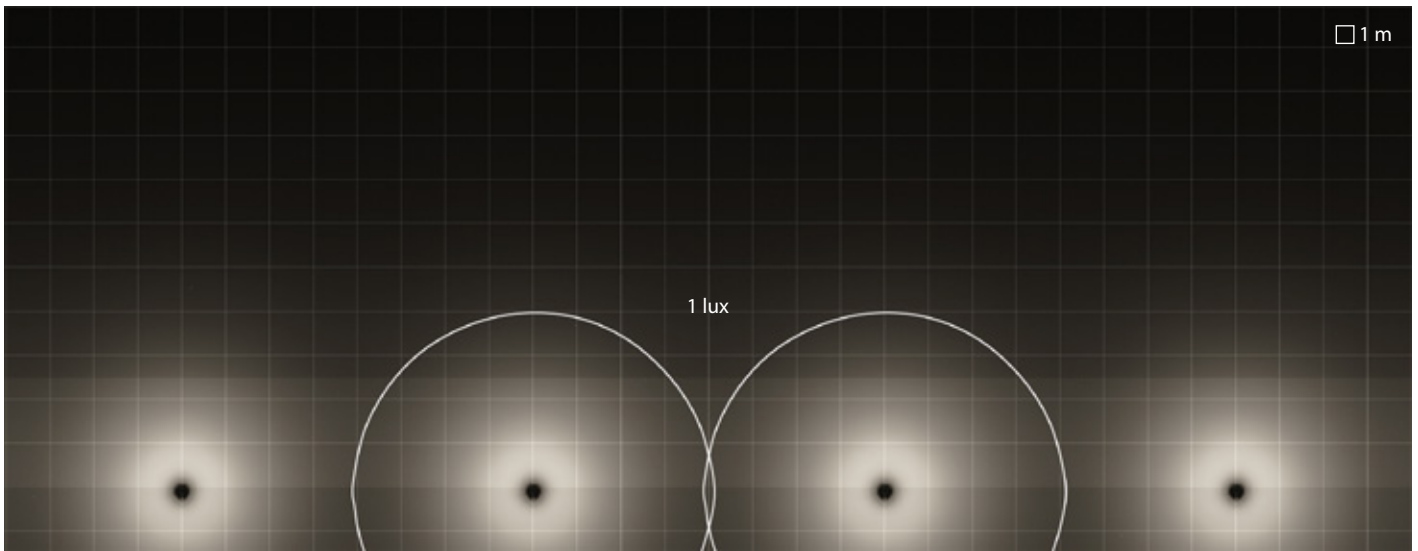

KHA SLIM 93 LED | C/EW extra wide circle reflector

Luminaire spacing = 8m
 Path depth = 2.5m
 Mounting height = 0m

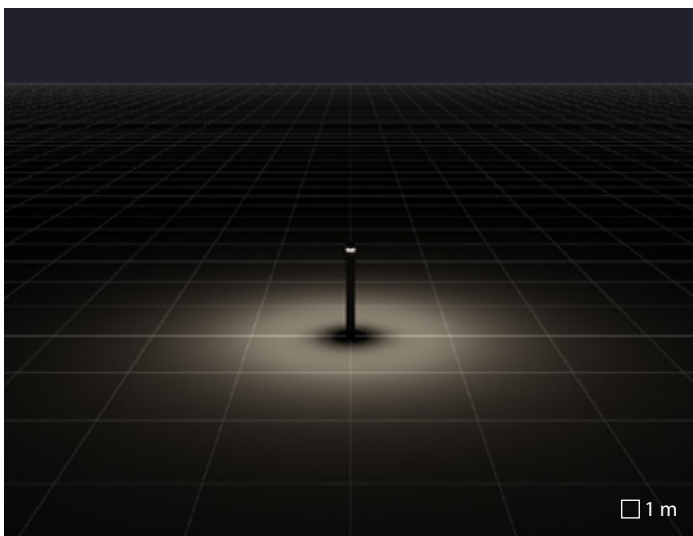

KHA SLIM 93 LED | C/EW extra wide circle reflector

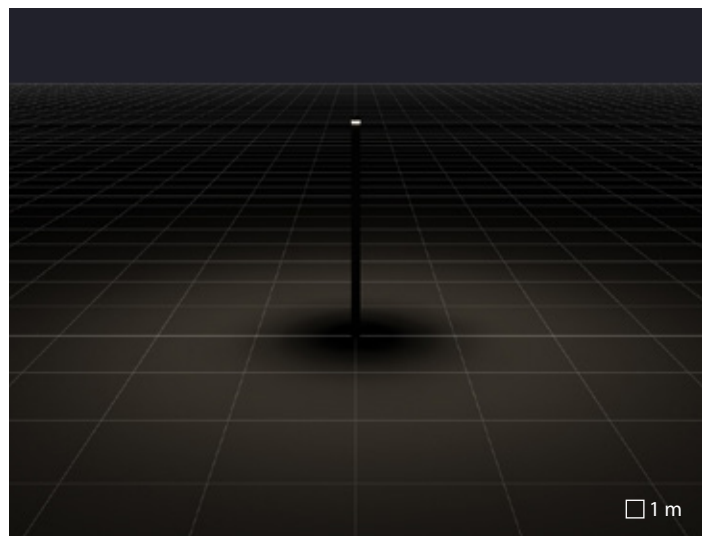

KHA SLIM 220 LED | C/EW extra wide circle reflector

AMON

Build to last

The name AMON, King of Gods in ancient Egypt, also meant “mysterious in shape”. From this concept, our team designed a robust, yet at the same time classy and elegant unique oval-shaped luminaire.

This series provides the project designer with versatile lighting solutions while ensuring reduced installation and maintenance costs. AMON is the perfect solution for tomorrow’s city due to the variety of product options and light distributions.

From zero light pollution, glare-free options to the “soft/comfortable” light using our UV stabilized polycarbonate option, the AMON is the versatile option for virtually any project.





New building electrical wholesaler Robri | Wekerom | Netherlands

AMON

Design-coordinated lighting column (AMON MAXI), bollard (AMON MINI) and wall pack (AMON WALL) series. Fixtures consist of:

Construction

- Extruded aluminium profile housing, painted ISO 9227
- Powder polyester painting process optimised against UV rays in 13 different steps guaranteed ISO9227 against salt spray 1000 hours
- Anti-ageing silicone gasket
- Extra-clear, tempered, flat glass diffuser, screen-printed inside
- Stainless steel external screws
- Painted die cast aluminium bracket for wall mounted (WALL) applications, for easy installation

Electrical

- Built-in driver

Installation

- The bracket for wall mounting simplifies maintenance and installation, by making it possible to complete the wiring on the ground and then hang the fixture body without the need for special tools (wall version).
- Stainless steel base plate to anchor the fitting to concrete available as an accessory

Variants

- DALI dimmable ballast available. Consult factory
- For other colour temperatures and different colour rendering index consult factory

Listings

- CE
- EAC
- RCM
- Made in Italy

Warranty

- 5-year limited warranty. Complete warranty terms located at www.performanceinlighting.com





		AMON WALL	AMON MINI	AMON MAXI
CONSTRUCTION				
IP		IP65	IP65	IP65
IK		IK08 5J xx5	IK07 2J xx5 IK09 10J xx7	IK07 2J xx5 IK08 5J xx5
Dimensions (mm)		L 238 x H 270 x D 173	L 238 x H 1200 x D 97	L 238 x H 3933 x D 97
Windage area	EPA - front	0,065 m ²	0,29 m ²	0,96 m ²
	EPA - side	0,026 m ²	0,117 m ²	0,38 m ²
	EPA - top	0,023 m ²	0,023 m ²	0,023 m ²
Weight		Max 6 kg	Max 22 kg	Max 36 kg
Colour		●	●	●
INSTALLATION				
Pre-wired		-	-	-
Quick		-	-	-
Continuous mounted luminaire		-	✓	✓
LED				
Lightsource lumen output	4000 K	3120 lm ÷ 6240 lm	5046 lm	3120 lm ÷ 10092 lm
Luminaire lumen output	4000 K	1786 lm ÷ 3622 lm	1900 lm ÷ 2024 lm	1514 lm ÷ 4144 lm
CCT - Correlated Color Temperature		4000 K (3000 K on request)	4000 K (3000 K on request)	4000 K (3000 K on request)
CRI / SDCM (macadam step)		80/3	80/3	80/3
Lifetime		L70B10@80000h	L70B10@150000h	L70B10@50000h L70B10@80000h
ULR<1		✓	-	-
CIEn°3>95		✓	-	-
OPTIC				
A15/M asymmetric medium reflector		A15/M	-	-
A17/M asymmetric medium reflector		-	-	A17/M
A30/M asymmetric medium reflector		A30/M	-	A30/M
S/EW symmetric extra wide reflector		-	S/EW	S/EW
S/W symmetric wide reflector		-	S/W	S/W
ELECTRICAL				
Wattage		28 W - 37 W - 56 W	41 W	29 W - 42 W - 81 W - 85 W
Class		I	I	I
EEl		-	-	-
Ta MAX° luminaire		30°C	30°C	25°C
Ta MIN° luminaire		-20°C	-20°C	-20°C
Dimmable 1-10V		✓	✓	✓
Dimmable DALI		-	-	-
COSφ ≥ 0,9		✓	✓	✓
SPD (10kV)		-	✓	✓
CONTROL SYSTEMS				
Automatic derating		-	-	-
Pilot wire command derating		-	-	-
Constant light output		-	-	-

● AN-96 / Anthracite gray / Textured



New building electrical wholesaler Robri | Wekerom | Netherlands

AMON WALL



The bracket for wall mounting simplifies maintenance and installation, by making it possible to complete the wiring on the ground and then hang the fixture body without the need for special tools (wall version).



Diffuser in internally frosted extra clear, tempered, flat glass

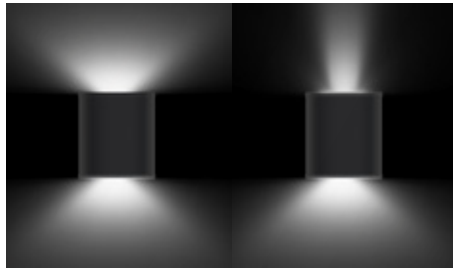

Double-emission (B) versions are equipped with two separate switches in order to provide upward and downward emission (DA)

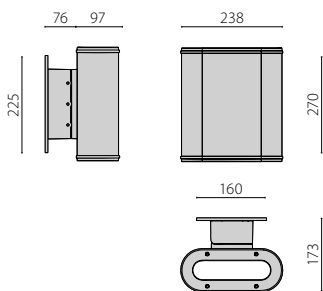

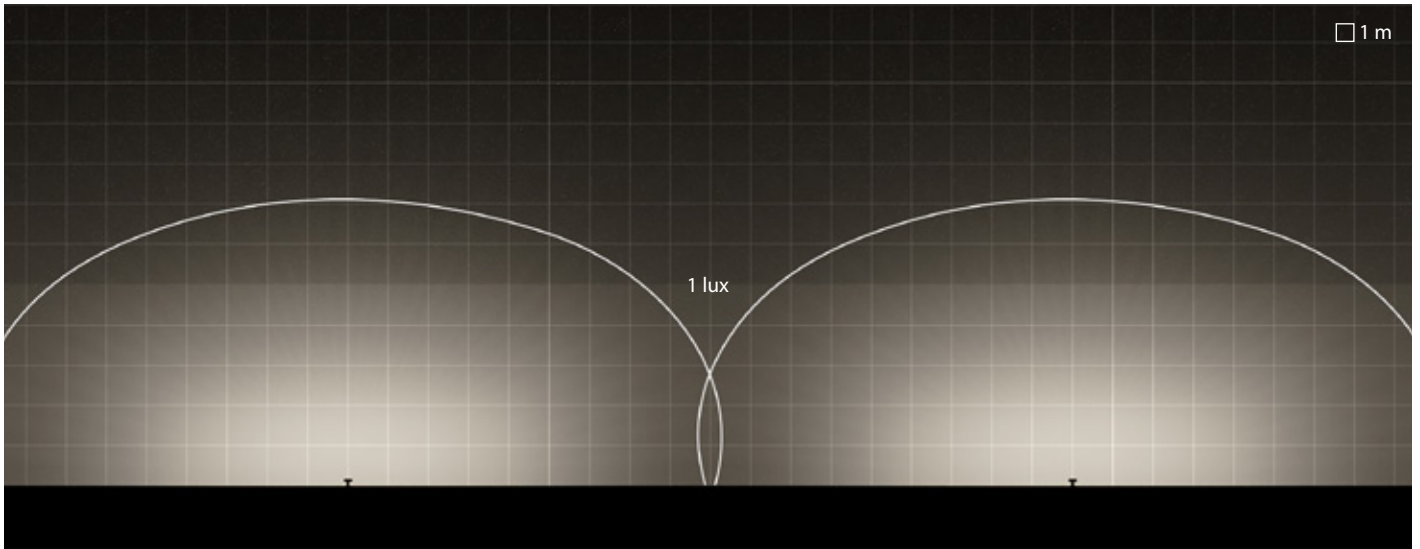

AMON WALL | A15/M | linear

Luminaire spacing = 18m
 Path depth = 5m
 Mounting height = 4m

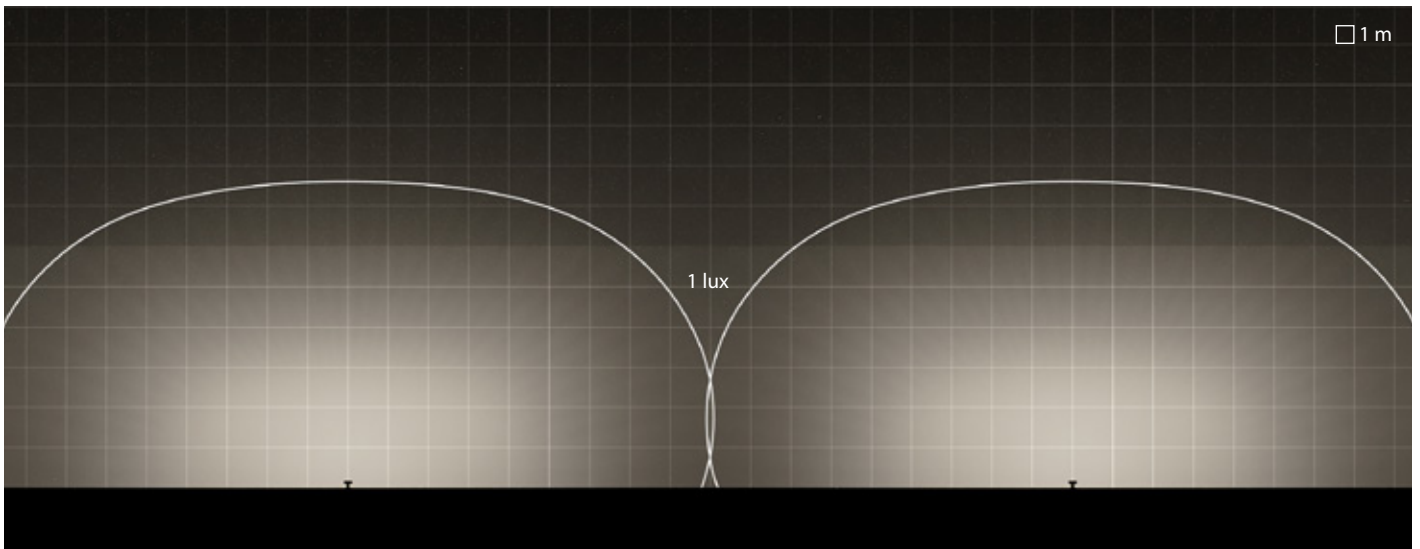

AMON WALL | A30/M | linear

Luminaire spacing = 18m
 Path depth = 6m
 Mounting height = 4m

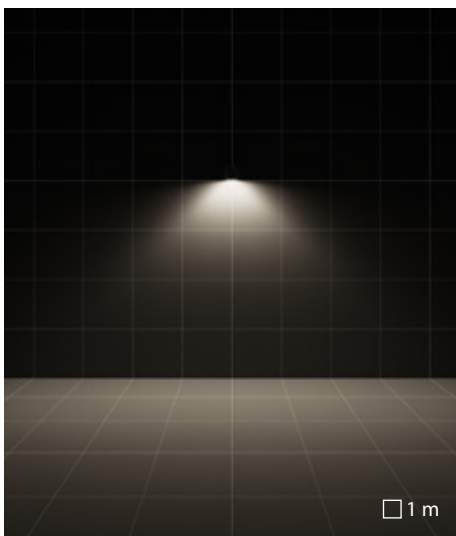

A15/M asymmetric medium reflector

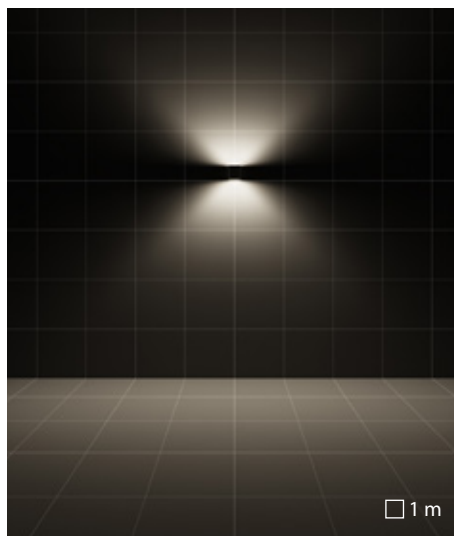

A15/M asymmetric medium reflector

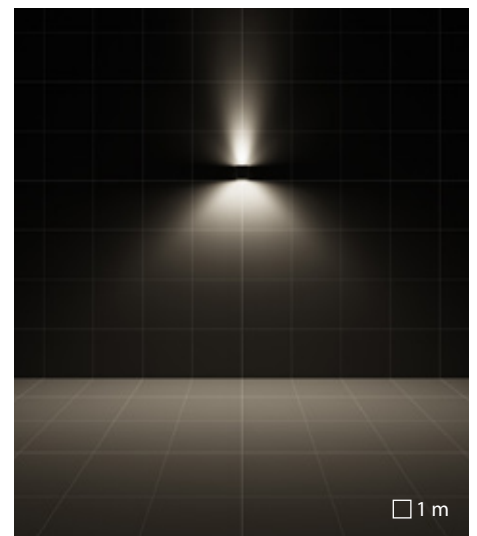

A15/M asymmetric medium reflector + S/I
 symmetric narrow reflector

AMON MINI

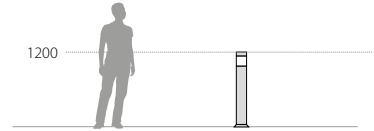

The SOFT version comes complete with satinized UV stabilized polycarbonate diffuser

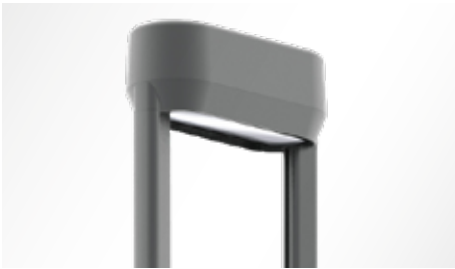

Diffuser in internally frosted extra clear, tempered, flat glass

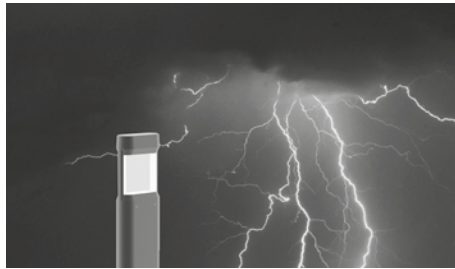

Complete with supplementary device for protection against network surges of up to 10 kV (DM)



Aesthetic painted die-cast aluminium flange cover for the base plate, available as accessory



Installation can make use of the accessory stainless steel ground plate to anchor the device to cement

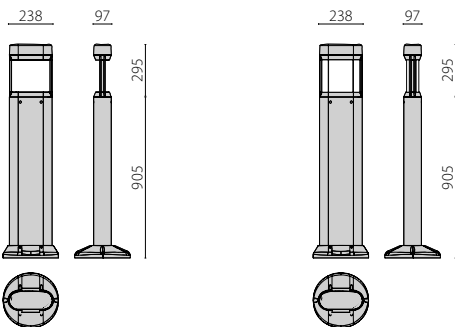

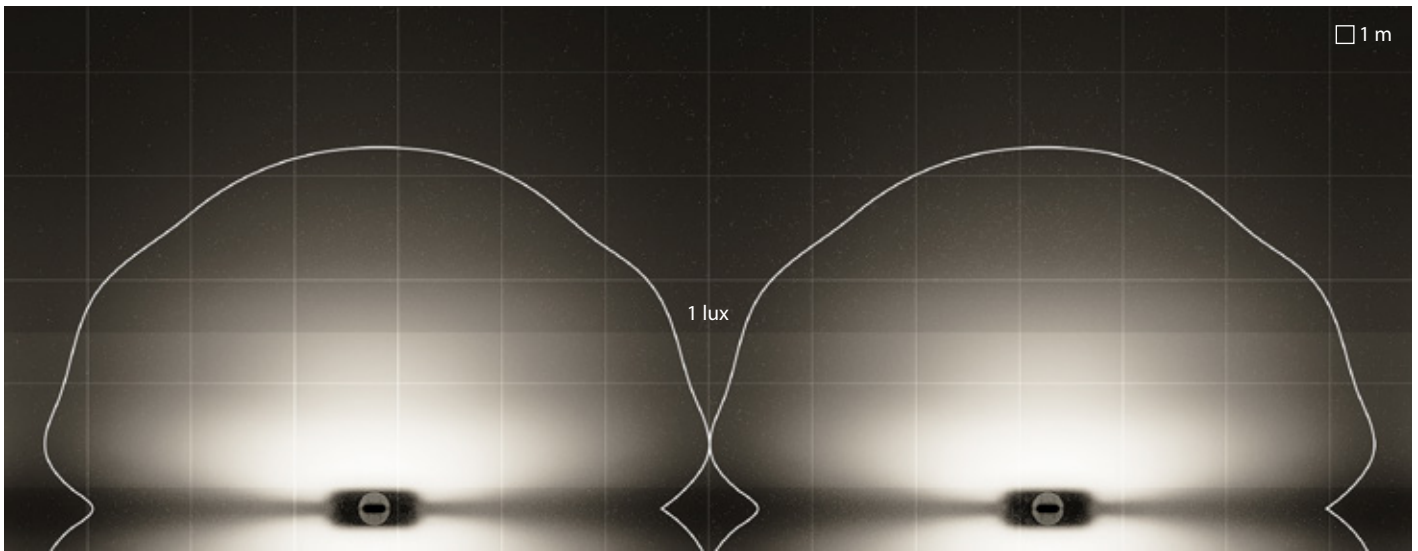

AMON MINI | S/W | linear

Luminaire spacing = 6.5m
 Path depth = 1.5m
 Mounting height = 0m

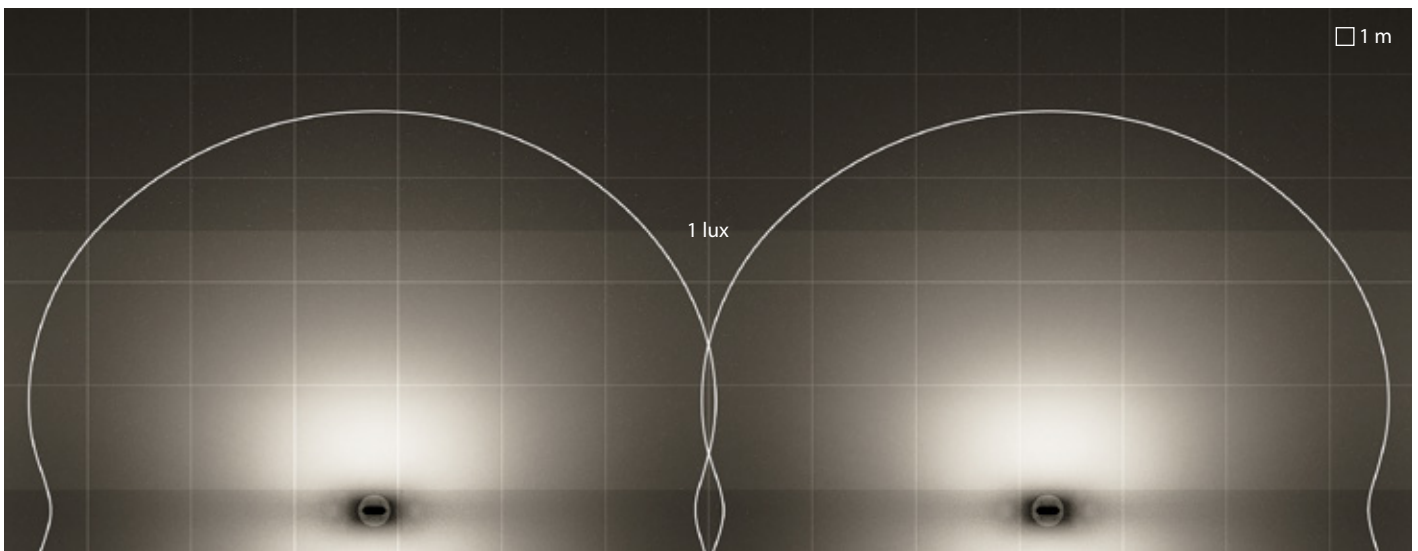

AMON MINI | SOFT S/EW | linear

Luminaire spacing = 6.5m
 Path depth = 2.5m
 Mounting height = 0m

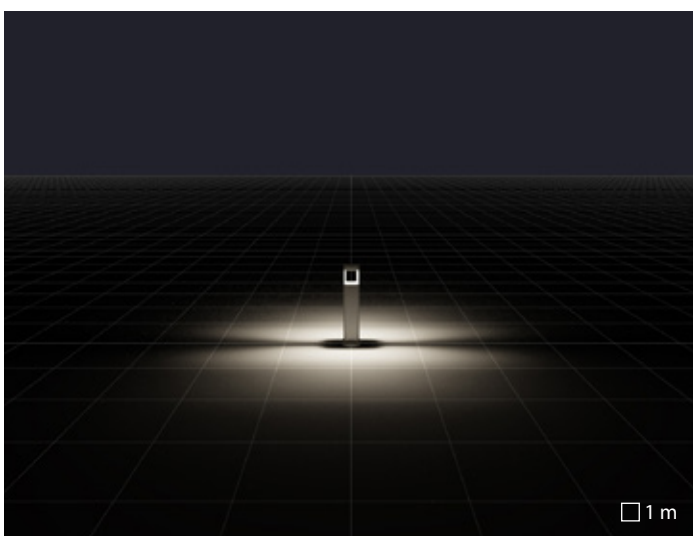

S/W symmetric wide reflector

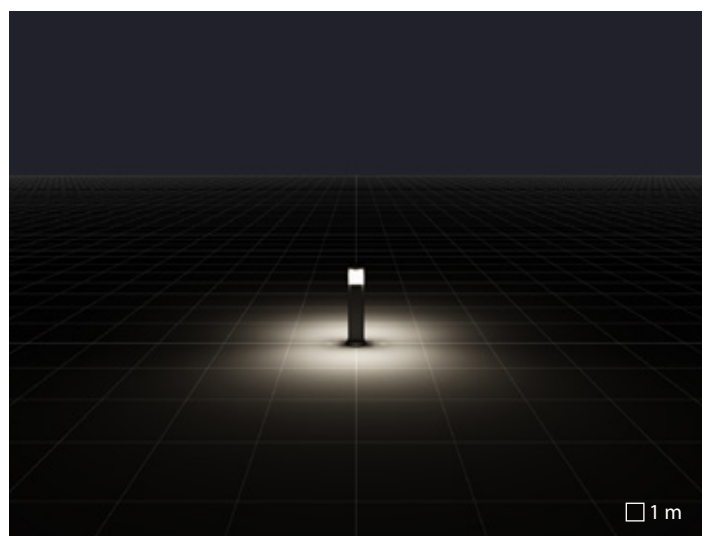

S/EW symmetric extra wide reflector

AMON MAXI



The SOFT version comes complete with opal UV stabilized polycarbonate diffuser

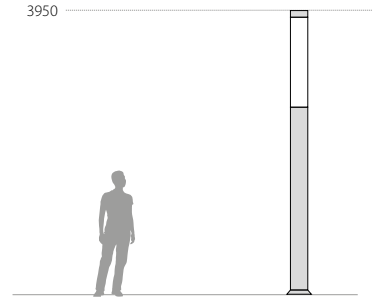

Diffuser in internally frosted extra clear, tempered, flat glass

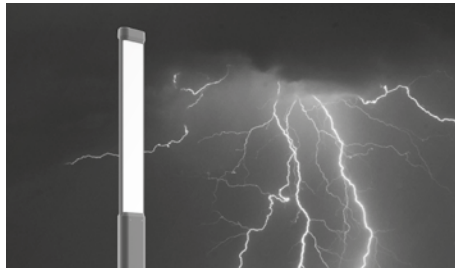

Complete with supplementary device for protection against network surges of up to 10 kV (DM)



Aesthetic painted die-cast aluminium flange cover for the base plate, available as accessory



Installation can make use of the accessory stainless steel ground plate to anchor the device to cement



Handhole made of painted die-cast aluminium

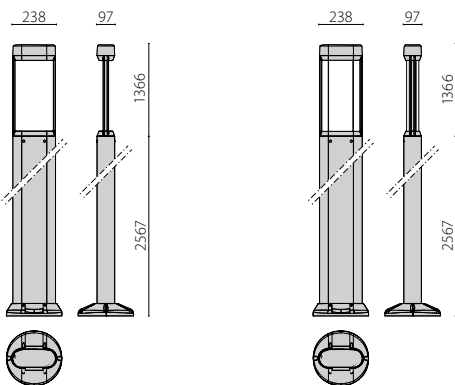

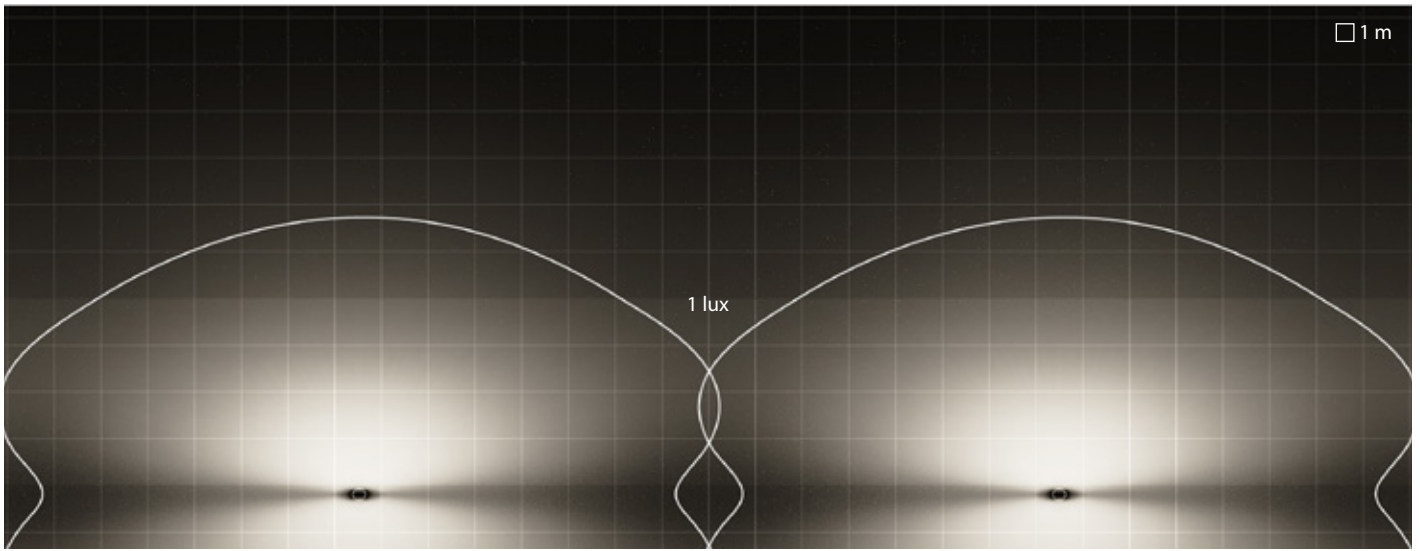

AMON MAXI | S/W | linear

Luminaire spacing = 15m
 Path depth = 4m
 Mounting height = 0m

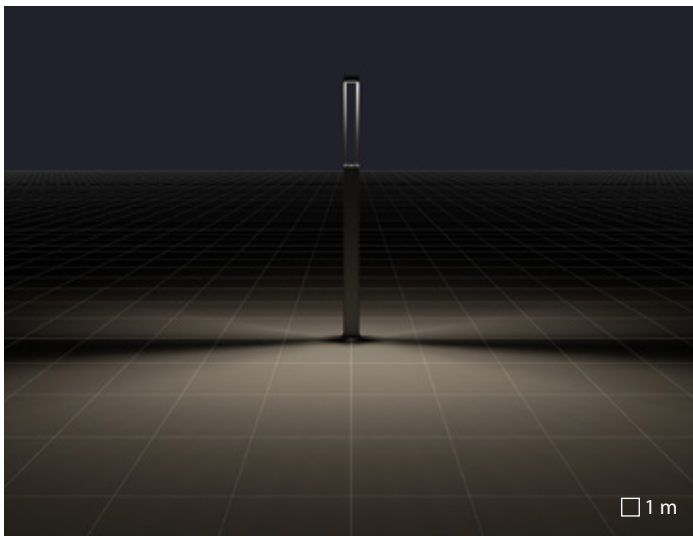

A17/M asymmetric medium reflector

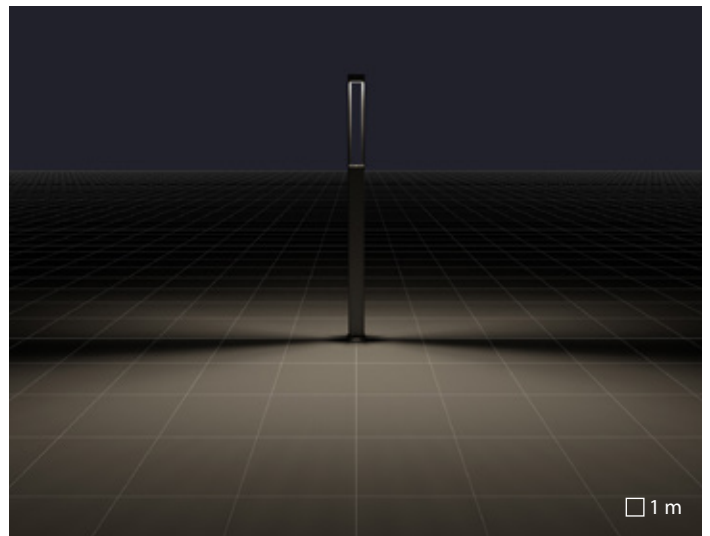

A30/M asymmetric medium reflector

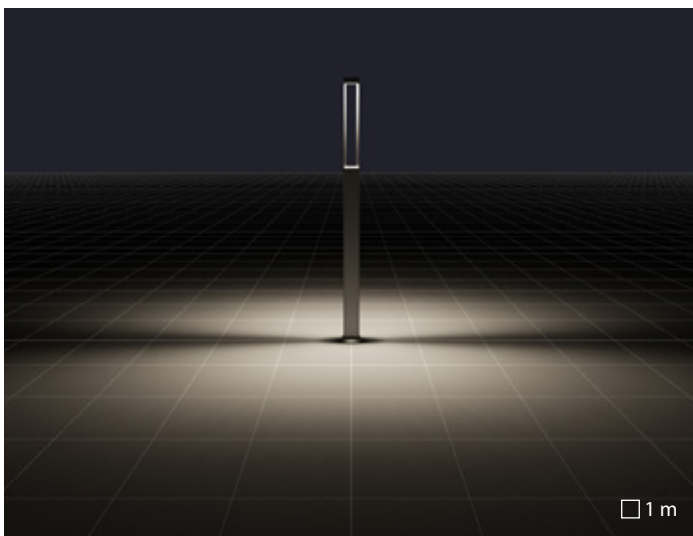

S/W symmetric wide reflector

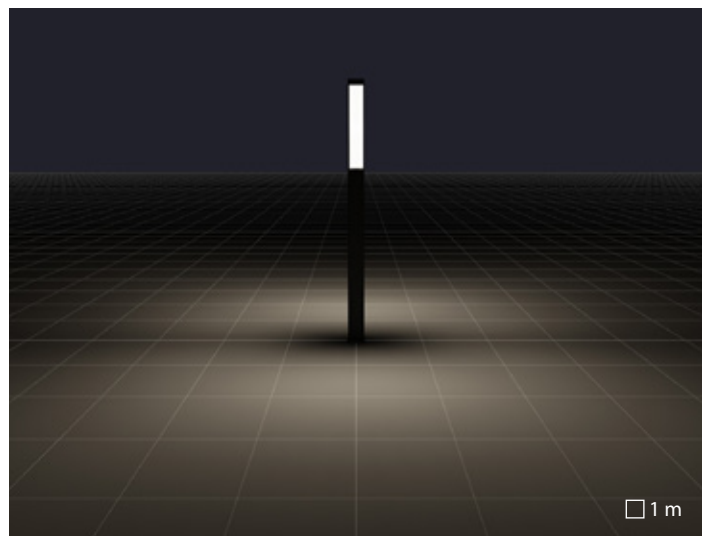

S/EW symmetric extra wide reflector

SPILLO

design Alessandro Pedretti

Starry light

SPILLO is at the forefront of the technology and image of new generation lighting fixtures, transmitting a message of quality and "comfort" of the urban environment; be it of a historical or contemporary nature, for green areas of traffic.

SPILLO MINI and SPILLO are innovative alternatives for the enhancement of the national heritage in public and private parks, cycle-pedestrian walkways, gardens, paths, commercial complexes of municipalities, towns, and cities.

Offering various optical distributions, the SPILLO is not only the most beautiful exterior fixture available, but it's also the smartest. With a complimentary bollard in the form of the SPILLO MINI, the SPILLO series is the new standard in urban lighting.

In compliance with the international light pollution/dark sky requirements, this product series is the perfect choice for your residential, urban and commercial projects.

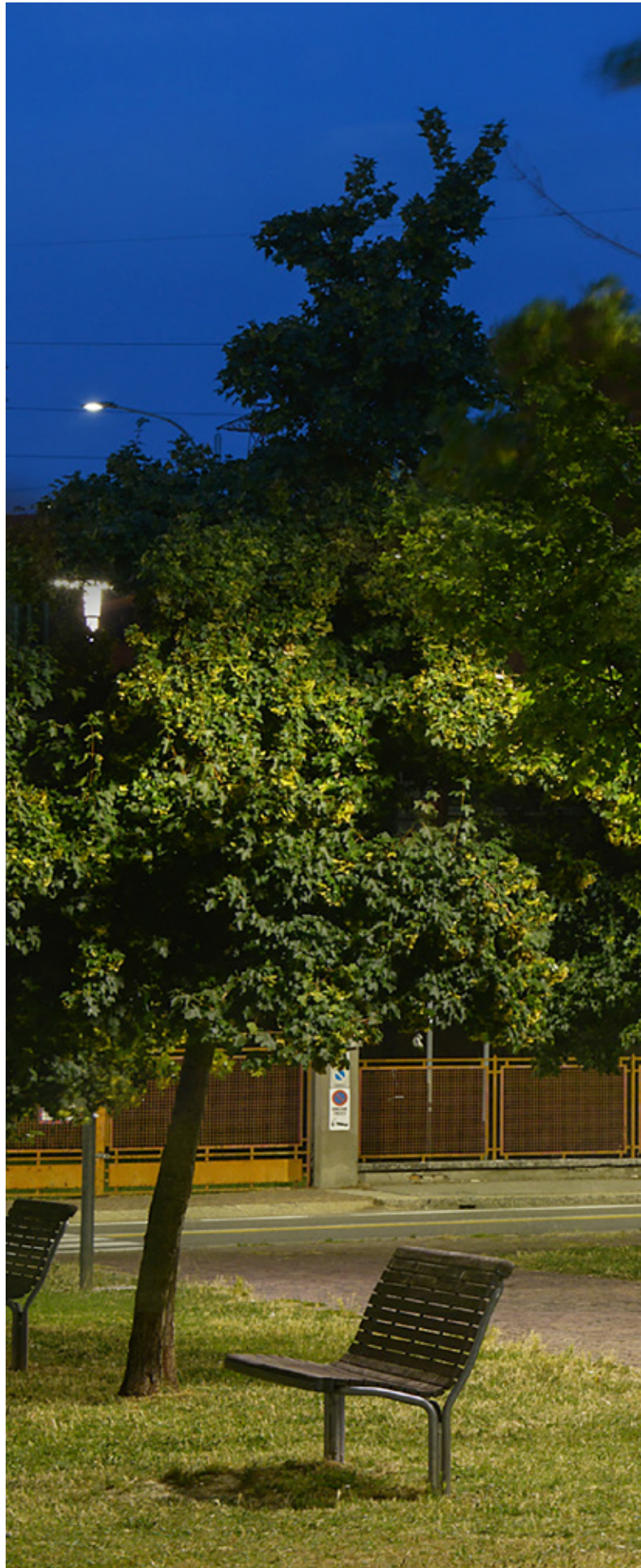



Navile public park | Bologna | Italy

SPILLO

design Alessandro Pedretti

Design-coordinated area/site lighting (SPILLO) and bollard (SPILLO MINI) series. Fixtures consist of:

Construction

- ISO 9227 painted die-cast aluminium housing
- Anti-ageing silicone gasket
- Stainless steel external screws

Electrical

- Supplied complete with 220/240 V 50/60 Hz power supply unit.
- Analogue dimmable HF ballast, 1-10 V
- The "SECURE LIGHT DISTRIBUTION" system guarantees uniform light distribution even in the remote case of LED failures
- Each LED is coupled with an electronic safety device (NUD) that can by-pass it in case of failure
- It is possible to replace the LED boards to keep the luminaire technologically updated through the years (consult factory).

Installation

- Suitable for pole-tops Ø 60 / 76 mm or on SPILLO pole Ø 90 mm
- Waterproof cable gland M25x1.5 for cables Ø 9- Ø 14 mm
- Supplied with 1m pre-wired HORN-5 cable
- External electrical connection with sealed plug-socket QUICK, complete with cable

Listings

- CE
- EAC
- RCM
- ENEC
- Complies with CAM for public lighting fixtures
- Made in Italy

Warranty

- 5-year limited warranty. Complete warranty terms located at www.performanceinlighting.com



SPILLO



SPILLO MINI

SPILLO MINI POST

SPILLO

CONSTRUCTION		SPILLO MINI	SPILLO MINI POST	SPILLO
IP		IP65	IP65	IP65
IK		IK10 20J xx9	IK10 20J xx9	IK10 20J xx9
Dimensions (mm)		H 187 x Ø 360	H 1187 x Ø 360	H 187 x Ø 587
Windage area	EPA - front	0,0047 m ²	0,081 m ²	0,0062 m ²
	EPA - side	0,101 m ²	0,101 m ²	0,264 m ²
	EPA - top	-	-	-
Weight		Max 3,21 kg	Max 5,11 kg	Max 7,59 kg
Colour		●	●	●
INSTALLATION				
Pre-wired		✓	✓	✓
Quick		✓	✓	✓
Continuous mounted luminaire		-	-	-
LED				
Lightsource lumen output	4000 K	1500 lm ÷ 2240 lm	1450 lm ÷ 2240 lm	3485 lm ÷ 6970 lm
Luminaire lumen output	4000 K	867 lm ÷ 1237 lm	867 lm ÷ 1237 lm	1767 lm ÷ 3998 lm
CCT - Correlated Color Temperature		4000 K (3000 K on request)	4000 K (3000 K on request)	4000 K (3000 K on request)
CRI / SDCM (macadam step)		70/3	70/3	70/3
Lifetime		L80B10@60000h	L80B10@60000h	L80B10@60000h
ULR<1		✓	✓	✓
CIEn°3>95		✓	✓	✓
OPTIC				
C/EW extra wide circle reflector		C/EW	C/EW	C/EW
CP pedestrian and cycle reflector		-	-	CP
ELECTRICAL				
Wattage		11 W - 16 W	11 W - 16 W	24 W - 44 W
Class		II	II	II
EEl		-	-	-
Ta MAX° luminaire		45°	45°	35° ÷ 25°
Ta MIN° luminaire		-25°	-25°	-25°
Dimmable 1-10V		✓	✓	✓
Dimmable DALI		-	-	-
COSφ ≥ 0,9		-	-	-
SPD (10kV)		(on request)	(on request)	(on request)
CONTROL SYSTEMS				
Automatic derating		-	-	✓
Pilot wire command derating		(on request)	(on request)	(on request)
Constant light output		-	-	-

● AN-96 / Anthracite gray / Textured



FINSTRAL | Gochsheimt | Germany

SPILLO MINI / SPILLO

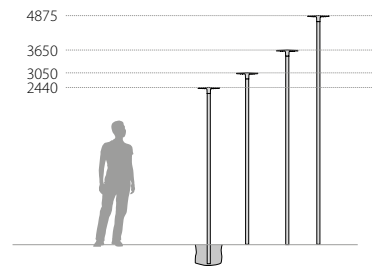
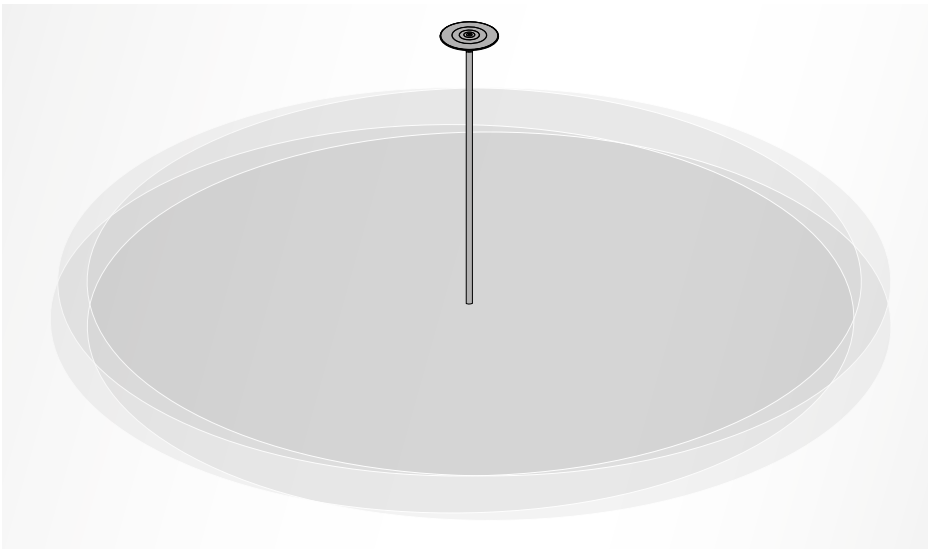

The "SECURE LIGHT DISTRIBUTION" system guarantees uniform light distribution even in the remote case of LED failures



Each LED is coupled with an electronic safety device (NUD) that can by-pass it in case of failure



Future proof. It is possible to replace the LED boards to keep the luminaire technologically updated through the years (consult factory)



Supplied with 1m pre-wired HORN5-5 cable



Suitable for pole-tops Ø 60 / 76 mm or on SPILLO pole Ø 90 mm



Complete with supplementary device for protection against network surges of up to 10 kV (DM)



External electrical connection with sealed plug-socket QUICK, complete with cable

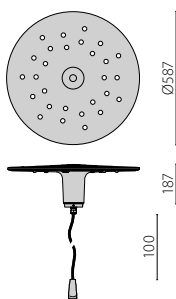
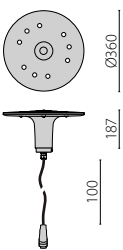

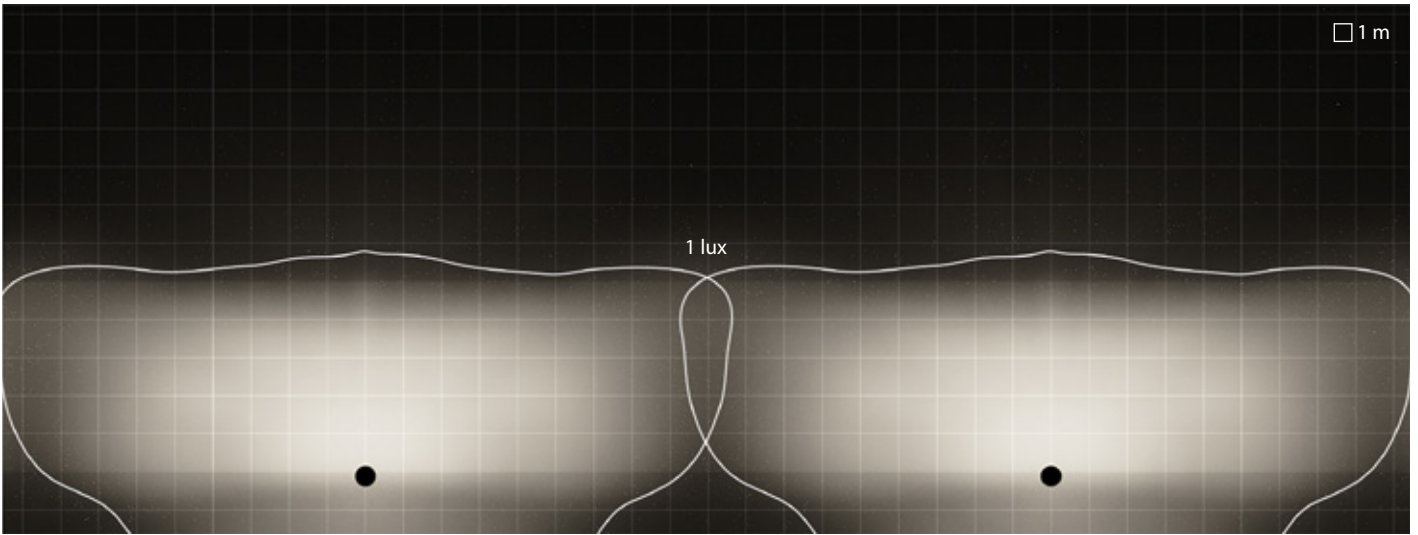

SPILLO | CP | linear

Luminaire spacing = 18m
 Path depth = 5m
 Mounting height = 3m

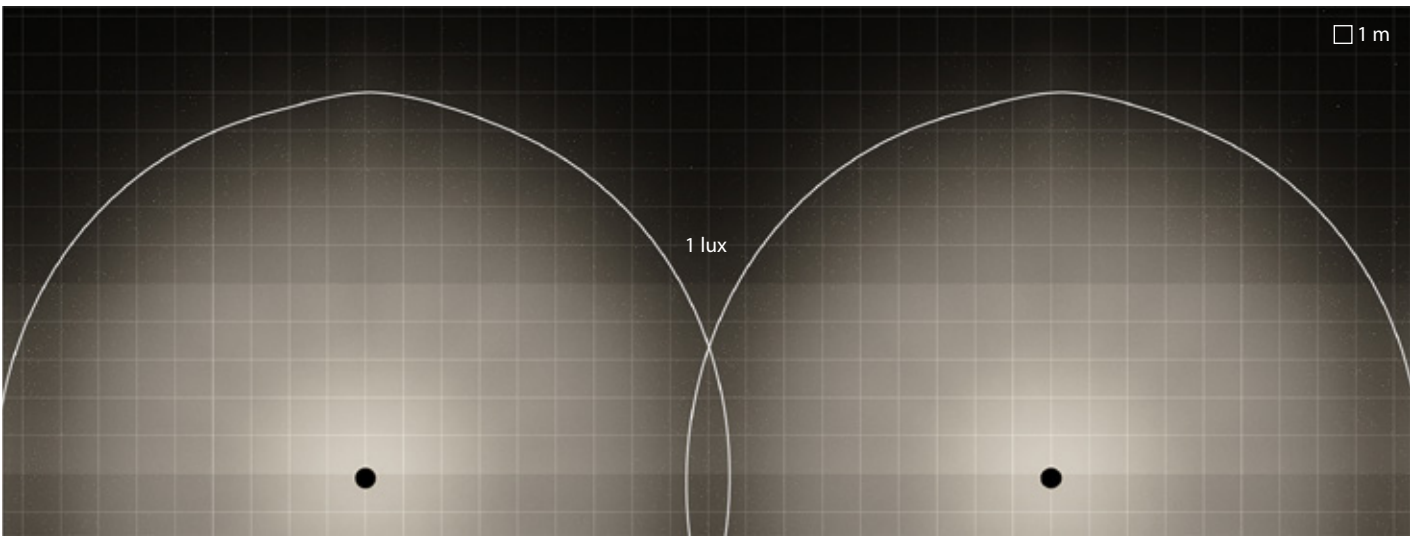

SPILLO | C/EW | linear

Luminaire spacing = 18m
 Path depth = 5m
 Mounting height = 3m

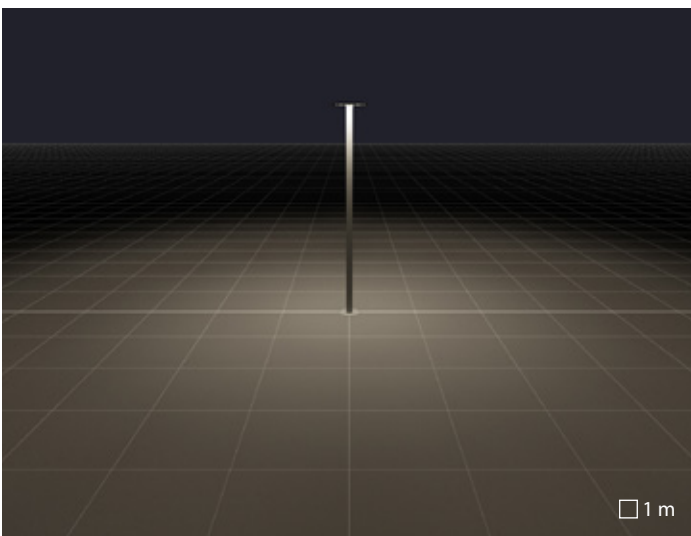

C/EW extra wide circle reflector

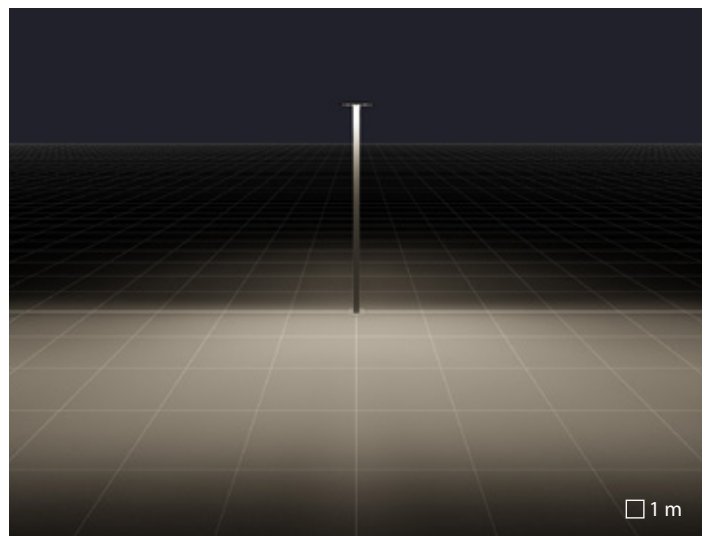

CP pedestrian and cycle reflector

SILLO MINI POST

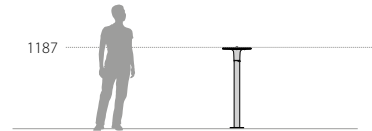
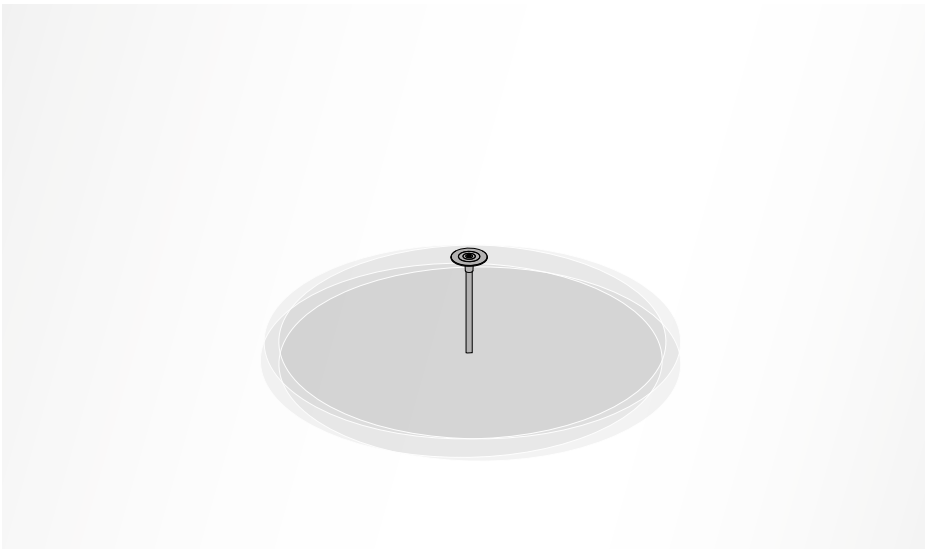

The "SECURE LIGHT DISTRIBUTION" system guarantees uniform light distribution even in the remote case of LED failures



Each LED is coupled with an electronic safety device (NUD) that can by-pass it in case of failure



Future proof. It is possible to replace the LED boards to keep the luminaire technologically updated through the years (consult factory)



External electrical connection with sealed plug-socket QUICK, complete with cable

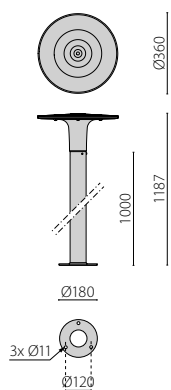

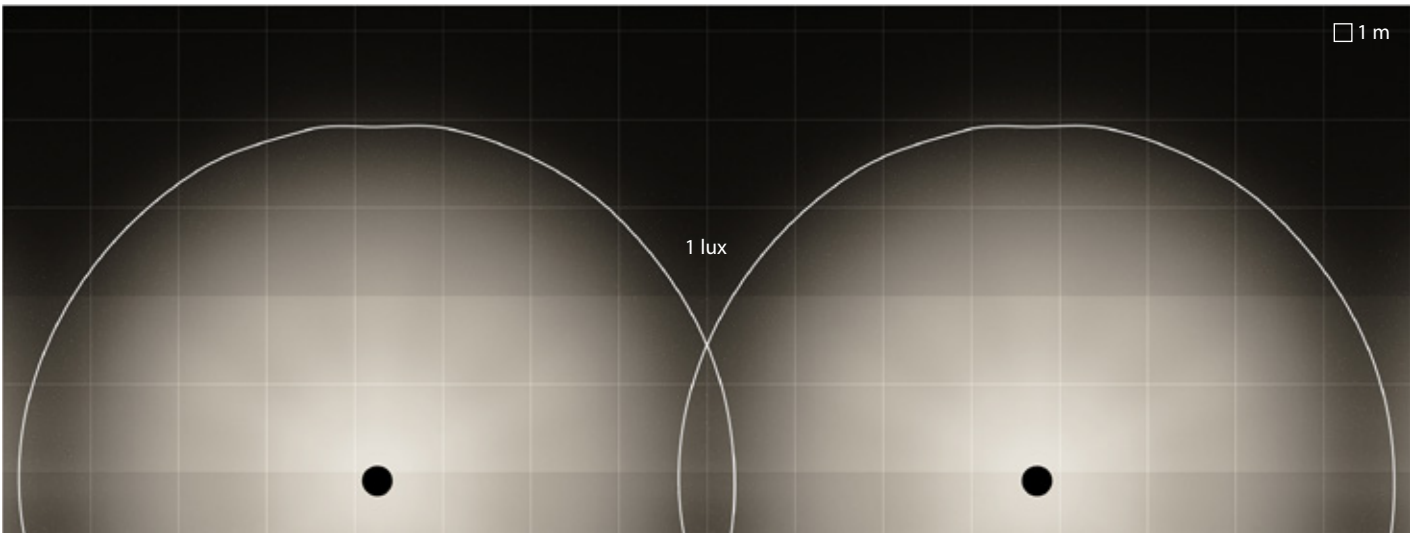

SPILLO MINI | C/EW | linear

Luminaire spacing = 7.5m
 Path depth = 2m
 Mounting height = 0m

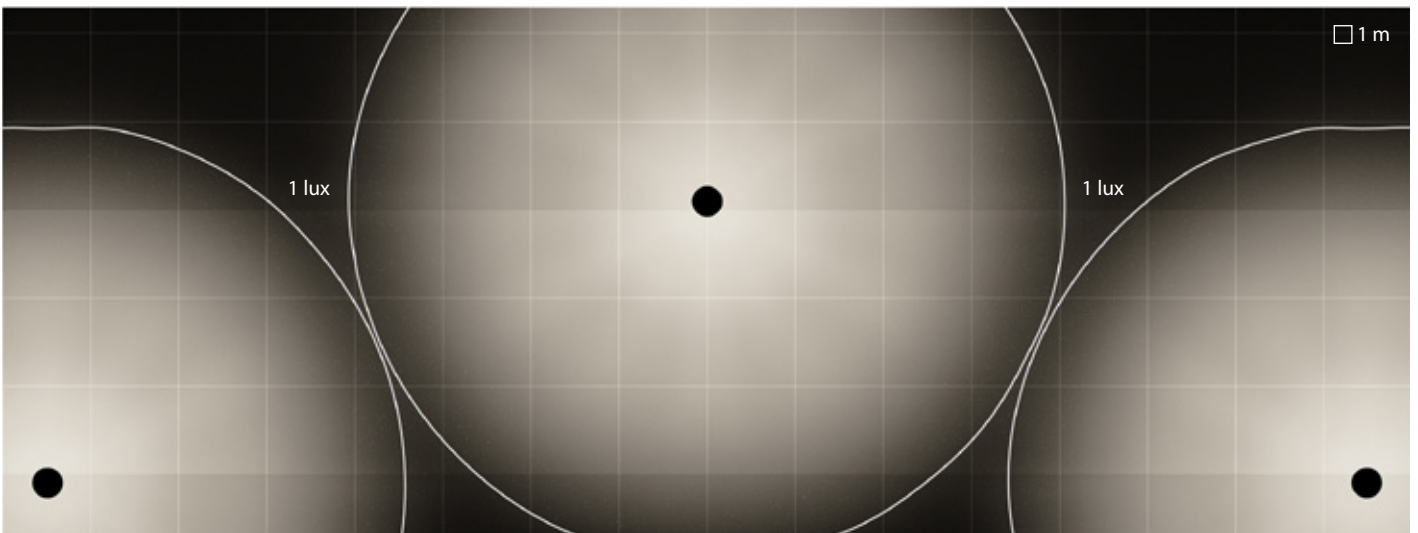

SPILLO MINI | C/EW | qunconce

Luminaire spacing = 7.5m
 Path depth = 3m
 Mounting height = 0m

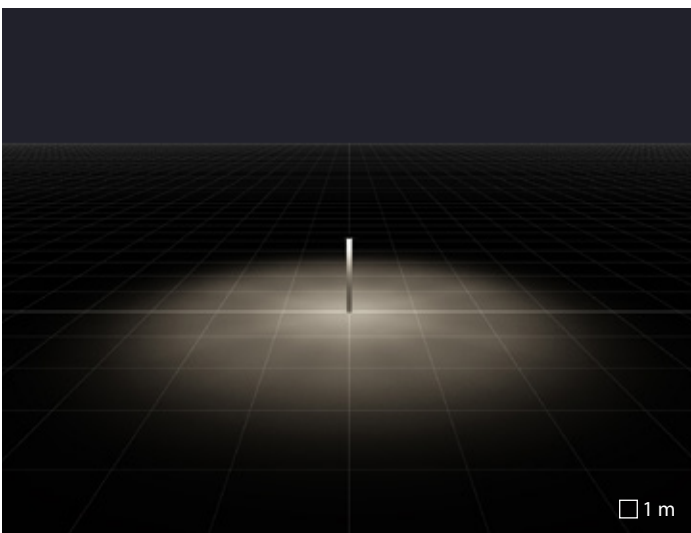

C/EW extra wide circle reflector

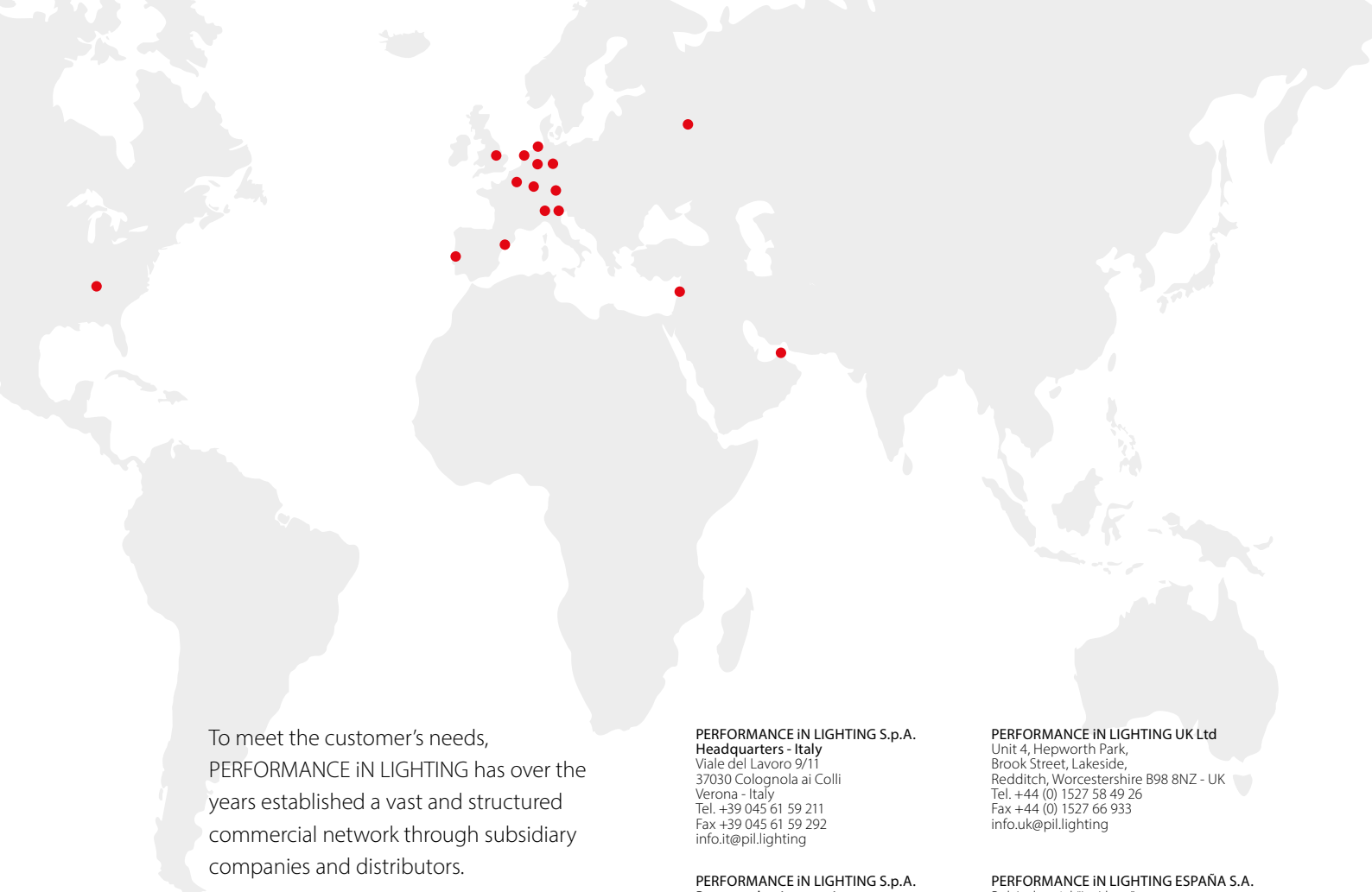

To meet the customer's needs, PERFORMANCE iN LIGHTING has over the years established a vast and structured commercial network through subsidiary companies and distributors.

The Group now exports to more than 100 countries worldwide.

PERFORMANCE iN LIGHTING S.p.A.
Headquarters - Italy
Viale del Lavoro 9/11
37030 Colognola ai Colli
Verona - Italy
Tel. +39 045 61 59 211
Fax +39 045 61 59 292
info.it@pil.lighting

PERFORMANCE iN LIGHTING S.p.A.
Bergamo business unit
Via Provinciale 57
24050 Ghisalba
Bergamo - Italy
Tel. +39 0363 94 06 11
Fax +39 0363 94 06 90
info.it@pil.lighting

PERFORMANCE iN LIGHTING GmbH
Headquarters - Germany
Stapelner Str. 1+3
38644 Goslar - Germany
Tel. +49 (0) 5321 3777 0
Fax +49 (0) 5321 3777 99
info.de@pil.lighting

PERFORMANCE iN LIGHTING GmbH
München business unit
Hauptstraße 27
82008 Unterhaching - Germany
Tel. +49 (0) 89/66 54 76 87 230
Fax +49 (0) 89/66 54 76 87 19
info.de@pil.lighting

PERFORMANCE iN LIGHTING GmbH
Düsseldorf business unit
Leichlinger Str. 14
40764 Langenfeld - Germany
Tel. +49 (0) 21 73/2 71 99 10
Fax +49 (0) 21 73/2 71 99 29
info.de@pil.lighting

PERFORMANCE iN LIGHTING BE
Chaussée de Haecht, 1880
Haachtsesteenweg, 1880
1130 Bruxelles / Brussel - Belgium
Tel. + 32 2 705 51 51
Fax + 32 2 705 12 87
info.be@pil.lighting

PERFORMANCE iN LIGHTING NEDERLAND
Ronde Tocht 1 C
1507 CC Zaandam - The Netherlands
Tel. + 31 75 6708 706
info.nl@pil.lighting

PERFORMANCE iN LIGHTING FRANCE S.A.S.
Parc d'Activités de la Couronne des Prés
107 Avenue des Pâtis - CS 50608 Epône
78417 Aubergenville Cedex - France
Tel. +33 1 3090 5360
Fax +33 1 3090 1681
info.fr@pil.lighting

PERFORMANCE iN LIGHTING UK Ltd
Unit 4, Hepworth Park,
Brook Street, Lakeside,
Redditch, Worcestershire B98 8NZ - UK
Tel. +44 (0) 1527 58 49 26
Fax +44 (0) 1527 66 933
info.uk@pil.lighting

PERFORMANCE iN LIGHTING ESPAÑA S.A.
Pol. Industrial "La Llana"
c/Pont de Can Claverí, 58
08191 Rubí (Barcelona) - Spain
Tel. +34 93 699 5554
Fax +34 93 699 5045
info.es@pil.lighting

PERFORMANCE iN LIGHTING PORTUGAL
Estrada da Circunvalação 3558 / 3560
4435-186 Porto - Portugal
Tel. +351 229 770 624
Fax +351 229 770 699
info.pt@pil.lighting

PERFORMANCE iN LIGHTING FINLAND Oy
Tikkurikuja 1
00750 Helsinki - Finland
Tel. +358 10422 1860
Fax +358 10422 1861
info.fi@pil.lighting

PERFORMANCE iN LIGHTING USA, Inc.
2621 Keys Pointe
Conyers GA 30013 - USA
Phone +1 770 822 2115
Fax +1 770 822 9925
info.usa@pil.lighting

PERFORMANCE iN LIGHTING - ISRAEL
Moshav Hagor Meshk 401, P.O.B. 9102 P.T.
Tel. +972 3 93 40 350
Fax +972 3 93 40 350
Mob +972 53 2280477

OOO PERFORMANCE iN LIGHTING RUSSIA
Reg. Office: Bolshoy Zlatoustinsky pereulok, 1,
building 1
101000 Moscow - Russian Federation
info.ru@pil.lighting

PERFORMANCE iN LIGHTING MIDDLE EAST
Dubai Airport Free Zone
P.O.Box. 371818, Dubai, U.A.E.
Tel. +971 4 2395146
info.mea@pil.lighting



PERFORMANCE iN LIGHTING S.p.A
Viale del Lavoro 9/11
37030 Colognola ai Colli (VR) - Italy
T +39 045 61 59 211
F +39 045 61 59 393

www.performanceinlighting.com