

# MOULDED CASE CIRCUIT BREAKERS

CATALOGUE  
OF MOULDED CASE CIRCUIT  
BREAKERS AND SWITCH DISCONNECTORS

VALID FROM 1<sup>ST</sup> APRIL 2020

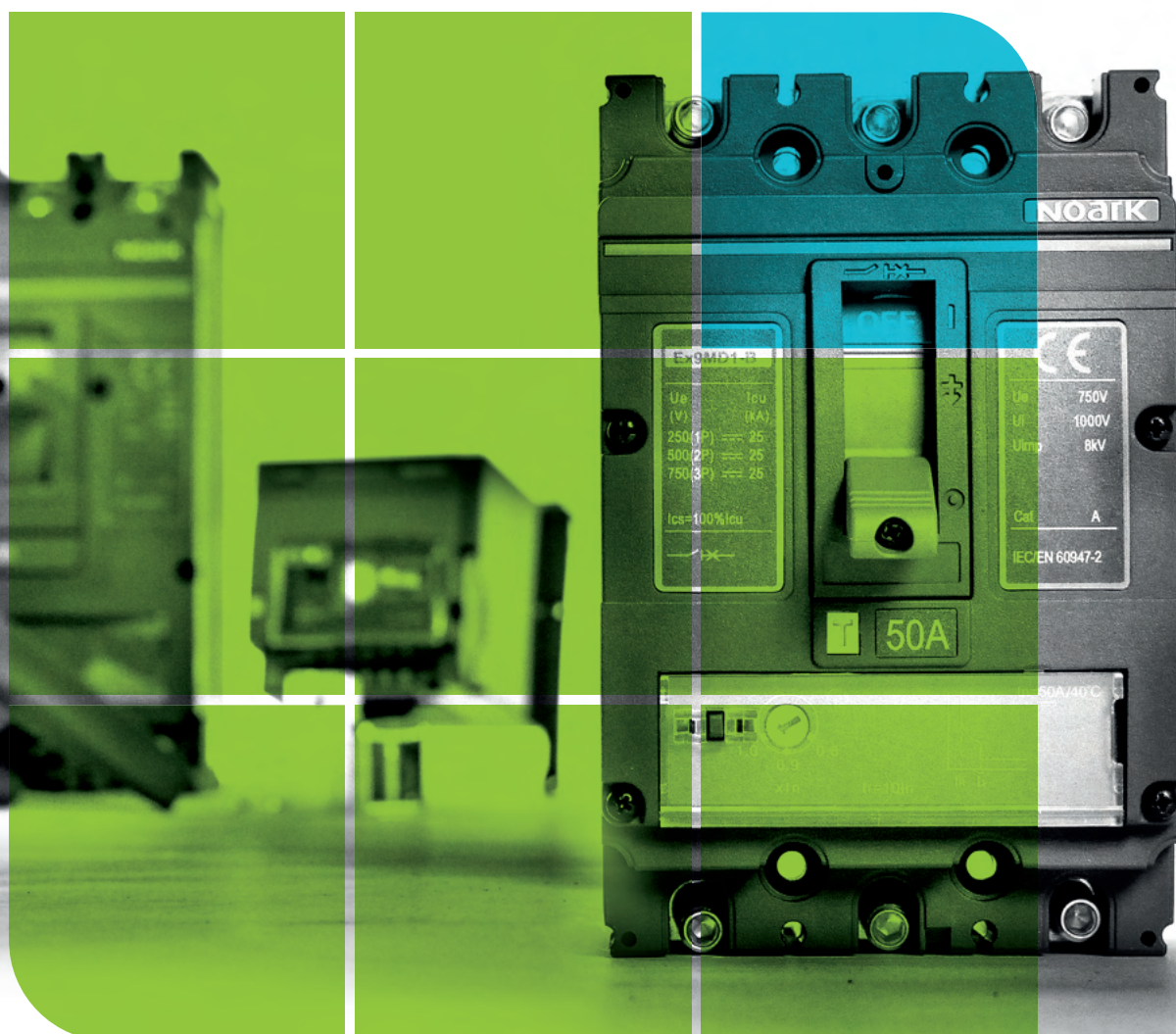

[www.noark-electric.eu](http://www.noark-electric.eu)

# NOARK

# Catalogues and assortment overview



## INSTALLATION DEVICES

- Miniature Circuit Breakers
- Fuse Holders and Disconnectors
- Isolators, Residual Current Devices
- Energy Meters
- Motor Protective Circuit Breakers
- Surge Protection Devices and other Installation Devices

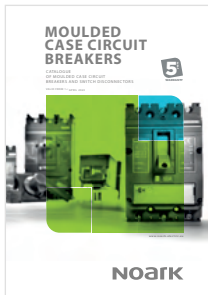

## MOULDED CASE CIRCUIT BREAKERS

- Moulded Case Circuit Breakers
- Moulded Case Switch Disconnectors
- DC Moulded Case Circuit Breakers
- DC Moulded Case Switch Disconnectors
- Accessories



## AIR CIRCUIT BREAKERS

- Digital Tripping Units
- Air Circuit Breakers
- Air Switch Disconnectors
- Accessories



## INDUSTRIAL DEVICES

- Industrial Relays and Contactors
- Motor Protective Circuit Breakers
- Overload Thermal Relays
- Panel Mounted Devices
- Accessories

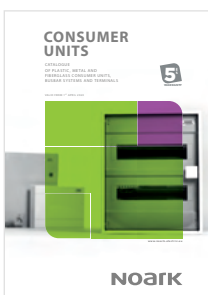

## CONSUMER UNITS

- Plastic Consumer Units
- Consumer Units with Metal Doors
- Metal Flat Enclosures
- Fiberglass Consumer Units
- Interconnection Busbars
- Terminals and Distribution Blocks



## PHOTOVOLTAIC COMPONENTS AND SOLUTIONS

- Miniature Circuit Breakers
- Fuse Disconnectors
- Isolators
- Surge Protection Devices
- Moulded Case Circuit Breakers and Switch Disconnectors
- EV chargers

# Contents

## Ordering information

<b>Moulded Case Circuit Breakers Ex9M</b>	
frame size M1 up to 125 A .....	8
frame size M2 up to 250 A .....	10
frame size M3 up to 400 A .....	12
frame size M4 up to 630 A .....	14
frame size M5 up to 800 A .....	16
frame size M6 up to 1600 A .....	19
frame size M6 MOD (motor operated) up to 1600 A .....	23
<b>MCCB Switch Disconnectors Ex9MSD</b>	
AC MCCB Switch Disconnectors up to 800 A .....	33
AC MCCB Switch Disconnectors up to 1600 A .....	37
<b>DC Moulded Case Circuit Breakers Ex9M</b>	
frame size M1 up to 125 A .....	44
frame size M2 up to 250 A .....	46
frame size M3 up to 400 A .....	48
frame size M4 up to 630 A .....	50
frame size M5 up to 800 A .....	52
Ex9MV2S for PV .....	55
<b>DC MCCB Switch Disconnectors Ex9MSD</b>	
DC MCCB Switch Disconnectors up to 800 A .....	57
<b>Accessories for MCCBs</b>	
Accessories for Ex9M1-5 .....	61
Accessories for Ex9M6 .....	67
Accessories for Ex9MV2S .....	71
<b>Technical data .....</b>	<b>73</b>
<b>Index .....</b>	<b>172</b>

# Contents

## Technical data

<b>Moulded Case Circuit Breakers Ex9M</b>	
frame size M1 up to 125 A .....	75
frame size M2 up to 250 A .....	78
frame size M3 up to 400 A .....	81
frame size M4 up to 630 A .....	84
frame size M5 up to 800 A .....	87
frame size M6 up to 1600 A .....	90
frame size M6 MOD (motor operated) up to 1600 A .....	94
<b>MCCB Switch Disconnectors Ex9MSD AC</b>	
frame size M1 up to 125 A .....	100
frame size M2 up to 250 A .....	103
frame size M3 up to 400 A .....	106
frame size M4 up to 630 A .....	109
frame size M5 up to 800 A .....	112
frame size M6 up to 1600 A .....	115
<b>DC Moulded Case Circuit Breakers Ex9M</b>	
frame size M1 up to 125 A .....	118
frame size M2 up to 250 A .....	121
frame size M3 up to 400 A .....	124
frame size M4 up to 630 A .....	127
frame size M5 up to 800 A .....	130
Ex9MV2S for PV .....	133
<b>DC MCCB Switch Disconnectors Ex9MSD DC</b>	
frame size M1 up to 125 A .....	136
frame size M2 up to 250 A .....	139
frame size M3 up to 400 A .....	142
frame size M4 up to 630 A .....	145
frame size M5 up to 800 A .....	148
<b>Accessories for MCCBs</b>	
<i>Accessories for Ex9M1-5</i>	
Auxiliary and signal contact units AX21, AL21 .....	151
Early-make auxiliary contacts EC .....	152
Shunt trip releases SHT2 .....	154
Undervoltage releases UVT2 .....	155
Direct rotary handles RHD2 .....	156
Extended rotary handles ERH2 .....	157
Remote operators MOD2 .....	159
Connection terminals MC2 .....	161
DIN-rail mounting adaptors DRA2 .....	162
Mounting depth spacers WG .....	163
<i>Accessories for Ex9M6</i>	
Auxiliary and signal contact units AX21, AL21 .....	164
Shunt trip releases SHT26 .....	165
Undervoltage releases UVT26 .....	166
Extended rotary handle ERH26 .....	167
Extended handle LHD26 .....	168
<i>Accessories for Ex9MV2S</i>	
Auxiliary and signal contact units AX22, AL22 .....	169
Shunt trip releases SHT22.....	170
Extended rotary handle ERH-1 .....	171

# Moulded Case Circuit Breakers



# Moulded Case Circuit Breakers

## Professional Tips

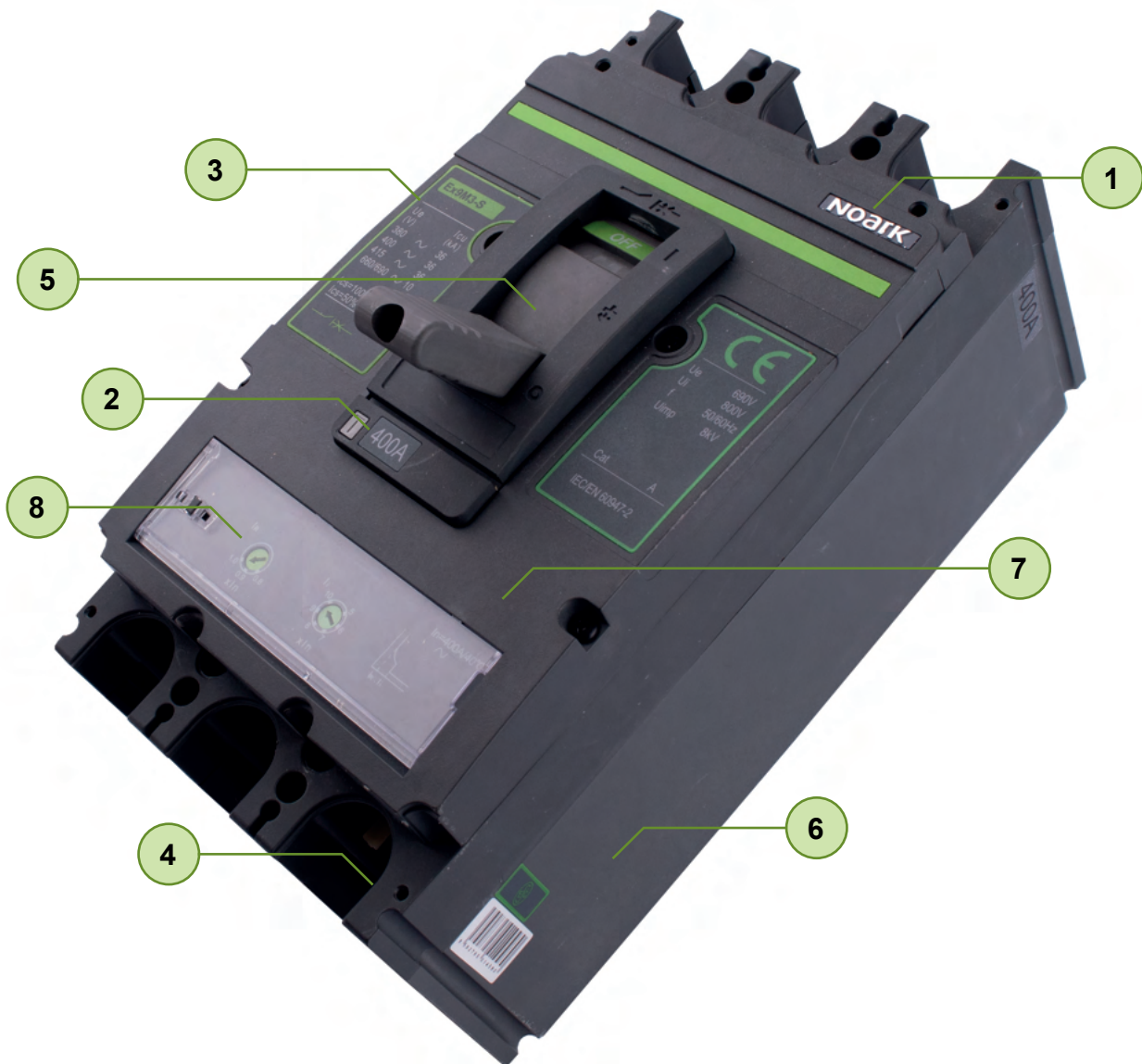

- 1 5 years warranty
- 2 Rated current from 16 A up to 1600 A
- 3 Breaking capacity up to 150 kA
- 4 3 and 4-pole versions available
- 5 Six frame sizes M1 - M6
- 6 AC and DC MCCBs and Switch disconnectors
- 7 Wide range of accessories
- 8 Thermomagnetic release for size M1-M5 and electronic release for size M6

# Moulded Case Circuit Breakers Ex9M



- Moulded Case Circuit Breakers
- Frame sizes M1-M5
- Rated current up to 800 A
- 3 and 4-pole versions
- Rated ultimate short circuit breaking capacity  $I_{cu}$  up to 150 kA,  $I_{cs} = 100 \% I_{cu}$
- Rated voltage 415 / 690 V AC
- Thermomagnetic releases
- Fixed versions

Moulded Case Circuit Breakers Ex9M TM are intended for applications in power distribution mainly. Testing according to IEC / EN 60947-2 standards ensures functions and reliability for wide variety of applications including isolation.

These breakers are offered with breaking capacities from 36 kA up to extreme 150 kA. Rated impulse withstand voltage  $U_{imp}$  8 kV makes it possible to use them even in system with occurrences of transient overvoltage waves of high intensity, e.g. in heavy industry.

Utilization category A circuit breakers.

## Type Key

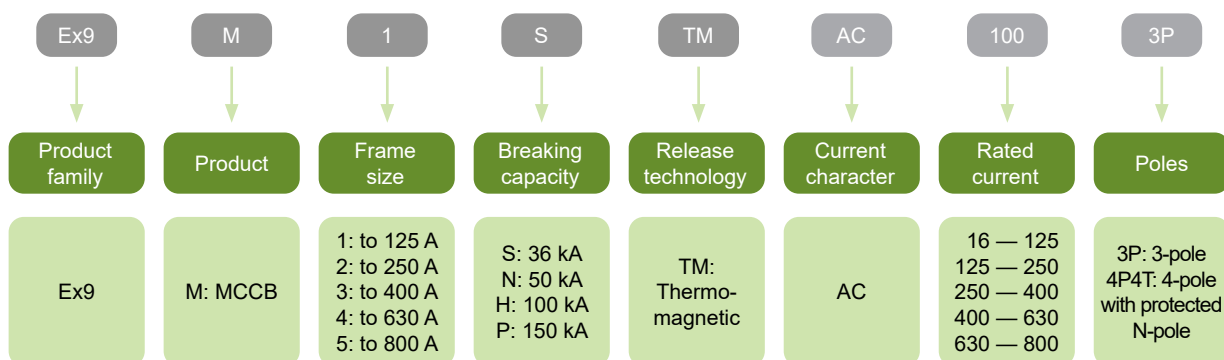

## Certification marks



# Moulded Case Circuit Breakers Ex9M

## Internal accessories

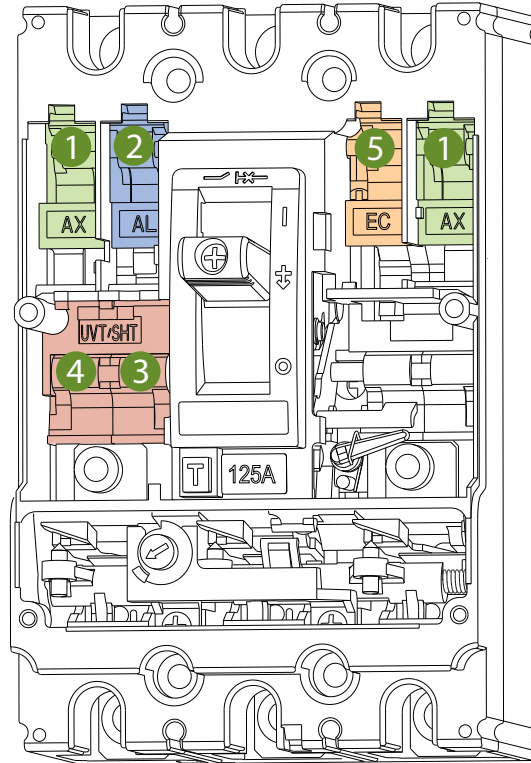

1

Auxiliary contact  
**AX21**

2

Signal contact  
**AL21**

3

Shunt trip release  
**SHT2i**  
1 unit or UVT2i

4

Undervoltage release  
**UVT2i**  
1 unit or SHT2i

5

Early-make  
auxiliary contact  
**EC 2i**

Auxiliary contact AX21

see page 62

Signal contact AL21

see page 62

Shunt trip releases SHT2i

see page 62

Undervoltage releases UVT2i

see page 63

Early-make auxiliary contact EC 2i

see page 62

All internal accessories for the frame sizes M2+M3 and M4+M5 are identical.



# Moulded Case Circuit Breakers Ex9M

## External accessories

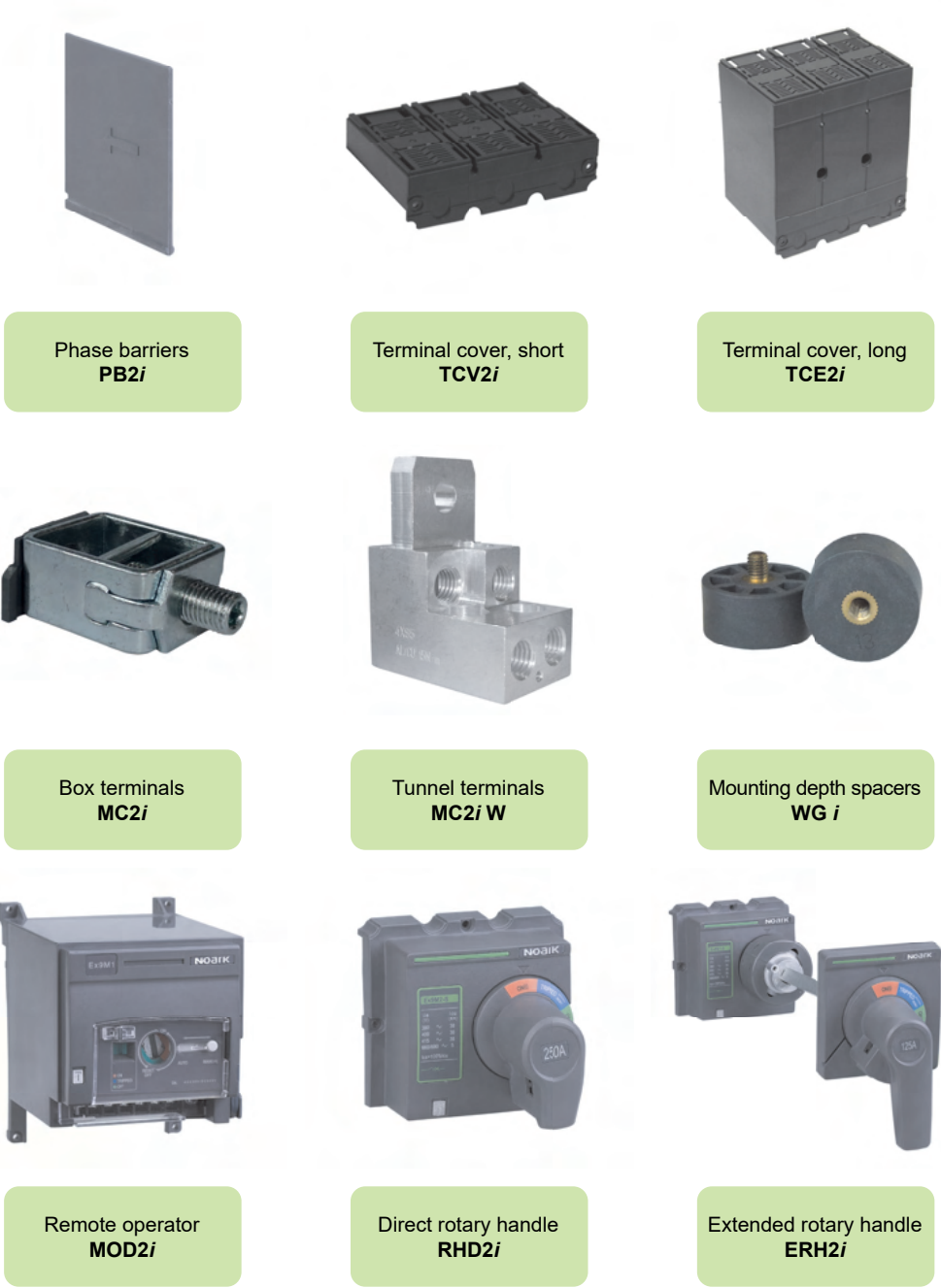

Phase barriers PB2i	see page 64
Terminal cover, short TCV2i	see page 65
Terminal cover, long TCE2i	see page 66
Remote operators MOD2i	see page 63
Direct rotary handles RHD2i	see page 64
Extended rotary handles ERH2i	see page 64
Connection terminals MC2i	see page 65
Mounting depth spacers WG i	see page 66

# Moulded Case Circuit Breakers Ex9M1

## Version Ex9M1S up to 125 A, $I_{cu} = 36$ kA

- 3 and 4-pole Moulded Case Circuit Breakers
- $I_{cs} = I_{cu} = 36$  kA at 415 V AC
- $I_r$  can be set in steps  $(0.8-0.9-1.0) \times I_n$
- $I_i$  fixed as  $10 \times I_n$
- Mounting screws, box terminals as well as phase barriers in the scope of delivery



Poles	Rated current $I_n$	Overcurrent release $I_r$	Instant. release $I_i$	Article No.	Type	Packing
3	16 A	12.8—16 A	160 A	100886	Ex9M1S TM AC16 3P	1/8
3	20 A	16—20 A	200 A	100887	Ex9M1S TM AC20 3P	1/8
3	25 A	20—25 A	250 A	100888	Ex9M1S TM AC25 3P	1/8
3	32 A	25.6—32 A	320 A	100889	Ex9M1S TM AC32 3P	1/8
3	40 A	32—40 A	400 A	100890	Ex9M1S TM AC40 3P	1/8
3	50 A	40—50 A	500 A	100891	Ex9M1S TM AC50 3P	1/8
3	63 A	50.4—63 A	630 A	100892	Ex9M1S TM AC63 3P	1/8
3	80 A	64—80 A	800 A	100893	Ex9M1S TM AC80 3P	1/8
3	100 A	80—100 A	1000 A	100894	Ex9M1S TM AC100 3P	1/8
3	125 A	100—125 A	1250 A	100895	Ex9M1S TM AC125 3P	1/8
4	16 A	12.8—16 A	160 A	103062	Ex9M1S TM AC16 4P4T	1/8
4	20 A	16—20 A	200 A	103063	Ex9M1S TM AC20 4P4T	1/8
4	25 A	20—25 A	250 A	103064	Ex9M1S TM AC25 4P4T	1/8
4	32 A	25.6—32 A	320 A	103065	Ex9M1S TM AC32 4P4T	1/8
4	40 A	32—40 A	400 A	103066	Ex9M1S TM AC40 4P4T	1/8
4	50 A	40—50 A	500 A	103067	Ex9M1S TM AC50 4P4T	1/8
4	63 A	50.4—63 A	630 A	103068	Ex9M1S TM AC63 4P4T	1/8
4	80 A	64—80 A	800 A	103069	Ex9M1S TM AC80 4P4T	1/8
4	100 A	80—100 A	1000 A	103070	Ex9M1S TM AC100 4P4T	1/8
4	125 A	100—125 A	1250 A	103071	Ex9M1S TM AC125 4P4T	1/8

## Version Ex9M1N up to 125 A, $I_{cu} = 50$ kA

- 3 and 4-pole Moulded Case Circuit Breakers
- $I_{cs} = I_{cu} = 50$  kA at 415 V AC
- $I_r$  can be set in steps  $(0.8-0.9-1.0) \times I_n$
- $I_i$  fixed as  $10 \times I_n$
- Mounting screws, box terminals as well as phase barriers in the scope of delivery



Poles	Rated current $I_n$	Overcurrent release $I_r$	Instant. release $I_i$	Article No.	Type	Packing
3	16 A	12.8—16 A	160 A	100896	Ex9M1N TM AC16 3P	1/8
3	20 A	16—20 A	200 A	100897	Ex9M1N TM AC20 3P	1/8
3	25 A	20—25 A	250 A	100898	Ex9M1N TM AC25 3P	1/8
3	32 A	25.6—32 A	320 A	100899	Ex9M1N TM AC32 3P	1/8
3	40 A	32—40 A	400 A	100900	Ex9M1N TM AC40 3P	1/8
3	50 A	40—50 A	500 A	100901	Ex9M1N TM AC50 3P	1/8
3	63 A	50.4—63 A	630 A	100902	Ex9M1N TM AC63 3P	1/8
3	80 A	64—80 A	800 A	100903	Ex9M1N TM AC80 3P	1/8
3	100 A	80—100 A	1000 A	100904	Ex9M1N TM AC100 3P	1/8
3	125 A	100—125 A	1250 A	100905	Ex9M1N TM AC125 3P	1/8
4	16 A	12.8—16 A	160 A	103072	Ex9M1N TM AC16 4P4T	1/8
4	20 A	16—20 A	200 A	103073	Ex9M1N TM AC20 4P4T	1/8
4	25 A	20—25 A	250 A	103074	Ex9M1N TM AC25 4P4T	1/8
4	32 A	25.6—32 A	320 A	103075	Ex9M1N TM AC32 4P4T	1/8
4	40 A	32—40 A	400 A	103076	Ex9M1N TM AC40 4P4T	1/8
4	50 A	40—50 A	500 A	103077	Ex9M1N TM AC50 4P4T	1/8
4	63 A	50.4—63 A	630 A	103078	Ex9M1N TM AC63 4P4T	1/8
4	80 A	64—80 A	800 A	103079	Ex9M1N TM AC80 4P4T	1/8
4	100 A	80—100 A	1000 A	103080	Ex9M1N TM AC100 4P4T	1/8
4	125 A	100—125 A	1250 A	103081	Ex9M1N TM AC125 4P4T	1/8

# Moulded Case Circuit Breakers Ex9M1

## Version Ex9M1H up to 125 A, $I_{cu} = 100$ kA

- 3 and 4-pole Moulded Case Circuit Breakers
- $I_{cs} = I_{cu} = 100$  kA at 415 V AC
- $I_r$  can be set in steps  $(0.8-0.9-1.0) \times I_n$
- $I_i$  fixed as  $10 \times I_n$
- Mounting screws, box terminals as well as phase barriers in the scope of delivery



Poles	Rated current $I_n$	Overcurrent release $I_r$	Instant. release $I_i$	Article No.	Type	Packing
3	16 A	12.8—16 A	160 A	100926	Ex9M1H TM AC16 3P	1/8
3	20 A	16—20 A	200 A	100927	Ex9M1H TM AC20 3P	1/8
3	25 A	20—25 A	250 A	100928	Ex9M1H TM AC25 3P	1/8
3	32 A	25.6—32 A	320 A	100929	Ex9M1H TM AC32 3P	1/8
3	40 A	32—40 A	400 A	100930	Ex9M1H TM AC40 3P	1/8
3	50 A	40—50 A	500 A	100931	Ex9M1H TM AC50 3P	1/8
3	63 A	50.4—63 A	630 A	100932	Ex9M1H TM AC63 3P	1/8
3	80 A	64—80 A	800 A	100933	Ex9M1H TM AC80 3P	1/8
3	100 A	80—100 A	1000 A	100934	Ex9M1H TM AC100 3P	1/8
3	125 A	100—125 A	1250 A	100935	Ex9M1H TM AC125 3P	1/8
4	16 A	12.8—16 A	160 A	103102	Ex9M1H TM AC16 4P4T	1/8
4	20 A	16—20 A	200 A	103103	Ex9M1H TM AC20 4P4T	1/8
4	25 A	20—25 A	250 A	103104	Ex9M1H TM AC25 4P4T	1/8
4	32 A	25.6—32 A	320 A	103105	Ex9M1H TM AC32 4P4T	1/8
4	40 A	32—40 A	400 A	103106	Ex9M1H TM AC40 4P4T	1/8
4	50 A	40—50 A	500 A	103107	Ex9M1H TM AC50 4P4T	1/8
4	63 A	50.4—63 A	630 A	103108	Ex9M1H TM AC63 4P4T	1/8
4	80 A	64—80 A	800 A	103109	Ex9M1H TM AC80 4P4T	1/8
4	100 A	80—100 A	1000 A	103110	Ex9M1H TM AC100 4P4T	1/8
4	125 A	100—125 A	1250 A	103111	Ex9M1H TM AC125 4P4T	1/8

## Version Ex9M1P up to 125 A, $I_{cu} = 150$ kA

- 3 and 4-pole Moulded Case Circuit Breakers
- $I_{cs} = I_{cu} = 150$  kA at 415 V AC
- $I_r$  can be set in steps  $(0.8-0.9-1.0) \times I_n$
- $I_i$  fixed as  $10 \times I_n$
- Mounting screws, box terminals as well as phase barriers in the scope of delivery



Poles	Rated current $I_n$	Overcurrent release $I_r$	Instant. release $I_i$	Article No.	Type	Packing
3	16 A	12.8—16 A	160 A	100946	Ex9M1P TM AC16 3P	1/8
3	20 A	16—20 A	200 A	100947	Ex9M1P TM AC20 3P	1/8
3	25 A	20—25 A	250 A	100948	Ex9M1P TM AC25 3P	1/8
3	32 A	25.6—32 A	320 A	100949	Ex9M1P TM AC32 3P	1/8
3	40 A	32—40 A	400 A	100950	Ex9M1P TM AC40 3P	1/8
3	50 A	40—50 A	500 A	100951	Ex9M1P TM AC50 3P	1/8
3	63 A	50.4—63 A	630 A	100952	Ex9M1P TM AC63 3P	1/8
3	80 A	64—80 A	800 A	100953	Ex9M1P TM AC80 3P	1/8
3	100 A	80—100 A	1000 A	100954	Ex9M1P TM AC100 3P	1/8
3	125 A	100—125 A	1250 A	100955	Ex9M1P TM AC125 3P	1/8
4	16 A	12.8—16 A	160 A	103122	Ex9M1P TM AC16 4P4T	1/8
4	20 A	16—20 A	200 A	103123	Ex9M1P TM AC20 4P4T	1/8
4	25 A	20—25 A	250 A	103124	Ex9M1P TM AC25 4P4T	1/8
4	32 A	25.6—32 A	320 A	103125	Ex9M1P TM AC32 4P4T	1/8
4	40 A	32—40 A	400 A	103126	Ex9M1P TM AC40 4P4T	1/8
4	50 A	40—50 A	500 A	103127	Ex9M1P TM AC50 4P4T	1/8
4	63 A	50.4—63 A	630 A	103128	Ex9M1P TM AC63 4P4T	1/8
4	80 A	64—80 A	800 A	103129	Ex9M1P TM AC80 4P4T	1/8
4	100 A	80—100 A	1000 A	103130	Ex9M1P TM AC100 4P4T	1/8
4	125 A	100—125 A	1250 A	103131	Ex9M1P TM AC125 4P4T	1/8

# Moulded Case Circuit Breakers Ex9M2

## Version Ex9M2S up to 250 A, $I_{cu} = 36$ kA

- 3 and 4-pole Moulded Case Circuit Breakers
- $I_{cs} = I_{cu} = 36$  kA at 415 V AC
- $I_r$  can be set in steps  $(0.8-0.9-1.0) \times I_n$
- $I_i$  variable  $(5-6-7-8-9-10) \times I_n$
- Mounting screws, box terminals as well as phase barriers in the scope of delivery



Poles	Rated current $I_n$	Overcurrent release $I_r$	Instant. release $I_i$	Article No.	Type	Packing
3	125 A	100-125 A	625-1250	101293	Ex9M2S TM AC125 3P	1/4
3	160 A	128-160 A	800-1600	101294	Ex9M2S TM AC160 3P	1/4
3	180 A	144-180 A	900-1800	101295	Ex9M2S TM AC180 3P	1/4
3	200 A	160-200 A	1000-2000	101296	Ex9M2S TM AC200 3P	1/4
3	225 A	180-225 A	1125-2250	101297	Ex9M2S TM AC225 3P	1/4
3	250 A	200-250 A	1250-2500	101298	Ex9M2S TM AC250 3P	1/4
4	125 A	100-125 A	625-1250	103132	Ex9M2S TM AC125 4P4T	1/4
4	160 A	128-160 A	800-1600	103133	Ex9M2S TM AC160 4P4T	1/4
4	180 A	144-180 A	900-1800	103134	Ex9M2S TM AC180 4P4T	1/4
4	200 A	160-200 A	1000-2000	103135	Ex9M2S TM AC200 4P4T	1/4
4	225 A	180-225 A	1125-2250	103136	Ex9M2S TM AC225 4P4T	1/4
4	250 A	200-250 A	1250-2500	103137	Ex9M2S TM AC250 4P4T	1/4

## Version Ex9M2N up to 250 A, $I_{cu} = 50$ kA

- 3 and 4-pole Moulded Case Circuit Breakers
- $I_{cs} = I_{cu} = 50$  kA at 415 V AC
- $I_r$  can be set in steps  $(0.8-0.9-1.0) \times I_n$
- $I_i$  variable  $(5-6-7-8-9-10) \times I_n$
- Mounting screws, box terminals as well as phase barriers in the scope of delivery



Poles	Rated current $I_n$	Overcurrent release $I_r$	Instant. release $I_i$	Article No.	Type	Packing
3	125 A	100-125 A	625-1250	101299	Ex9M2N TM AC125 3P	1/4
3	160 A	128-160 A	800-1600	101300	Ex9M2N TM AC160 3P	1/4
3	180 A	144-180 A	900-1800	101301	Ex9M2N TM AC180 3P	1/4
3	200 A	160-200 A	1000-2000	101302	Ex9M2N TM AC200 3P	1/4
3	225 A	180-225 A	1125-2250	101303	Ex9M2N TM AC225 3P	1/4
3	250 A	200-250 A	1250-2500	101304	Ex9M2N TM AC250 3P	1/4
4	125 A	100-125 A	625-1250	103138	Ex9M2N TM AC125 4P4T	1/4
4	160 A	128-160 A	800-1600	103139	Ex9M2N TM AC160 4P4T	1/4
4	180 A	144-180 A	900-1800	103140	Ex9M2N TM AC180 4P4T	1/4
4	200 A	160-200 A	1000-2000	103141	Ex9M2N TM AC200 4P4T	1/4
4	225 A	180-225 A	1125-2250	103142	Ex9M2N TM AC225 4P4T	1/4
4	250 A	200-250 A	1250-2500	103143	Ex9M2N TM AC250 4P4T	1/4

# Moulded Case Circuit Breakers Ex9M2

## Version Ex9M2H up to 250 A, $I_{cu} = 100$ kA

- 3 and 4-pole Moulded Case Circuit Breakers
- $I_{cs} = I_{cu} = 100$  kA at 415 V AC
- $I_r$  can be set in steps  $(0.8-0.9-1.0) \times I_n$
- $I_i$  variable  $(5-6-7-8-9-10) \times I_n$
- Mounting screws, box terminals as well as phase barriers in the scope of delivery



Poles	Rated current $I_n$	Overcurrent release $I_r$	Instant. release $I_i$	Article No.	Type	Packing
3	125 A	100-125 A	625-1250	101317	Ex9M2H TM AC125 3P	1/4
3	160 A	128-160 A	800-1600	101318	Ex9M2H TM AC160 3P	1/4
3	180 A	144-180 A	900-1800	101319	Ex9M2H TM AC180 3P	1/4
3	200 A	160-200 A	1000-2000	101320	Ex9M2H TM AC200 3P	1/4
3	225 A	180-225 A	1125-2250	101321	Ex9M2H TM AC225 3P	1/4
3	250 A	200-250 A	1250-2500	101322	Ex9M2H TM AC250 3P	1/4
4	125 A	100-125 A	625-1250	103156	Ex9M2H TM AC125 4P4T	1/4
4	160 A	128-160 A	800-1600	103157	Ex9M2H TM AC160 4P4T	1/4
4	180 A	144-180 A	900-1800	103158	Ex9M2H TM AC180 4P4T	1/4
4	200 A	160-200 A	1000-2000	103159	Ex9M2H TM AC200 4P4T	1/4
4	225 A	180-225 A	1125-2250	103160	Ex9M2H TM AC225 4P4T	1/4
4	250 A	200-250 A	1250-2500	103161	Ex9M2H TM AC250 4P4T	1/4

## Version Ex9M2P up to 250 A, $I_{cu} = 150$ kA

- 3 and 4-pole Moulded Case Circuit Breakers
- $I_{cs} = I_{cu} = 150$  kA at 415 V AC
- $I_r$  can be set in steps  $(0.8-0.9-1.0) \times I_n$
- $I_i$  variable  $(5-6-7-8-9-10) \times I_n$
- Mounting screws, box terminals as well as phase barriers in the scope of delivery



Poles	Rated current $I_n$	Overcurrent release $I_r$	Instant. release $I_i$	Article No.	Type	Packing
3	125 A	100-125 A	625-1250	101329	Ex9M2P TM AC125 3P	1/4
3	160 A	128-160 A	800-1600	101330	Ex9M2P TM AC160 3P	1/4
3	180 A	144-180 A	900-1800	101331	Ex9M2P TM AC180 3P	1/4
3	200 A	160-200 A	1000-2000	101332	Ex9M2P TM AC200 3P	1/4
3	225 A	180-225 A	1125-2250	101333	Ex9M2P TM AC225 3P	1/4
3	250 A	200-250 A	1250-2500	101334	Ex9M2P TM AC250 3P	1/4
4	125 A	100-125 A	625-1250	103168	Ex9M2P TM AC125 4P4T	1/4
4	160 A	128-160 A	800-1600	103169	Ex9M2P TM AC160 4P4T	1/4
4	180 A	144-180 A	900-1800	103170	Ex9M2P TM AC180 4P4T	1/4
4	200 A	160-200 A	1000-2000	103171	Ex9M2P TM AC200 4P4T	1/4
4	225 A	180-225 A	1125-2250	103172	Ex9M2P TM AC225 4P4T	1/4
4	250 A	200-250 A	1250-2500	103173	Ex9M2P TM AC250 4P4T	1/4

# Moulded Case Circuit Breakers Ex9M3

## Version Ex9M3S up to 400 A, $I_{cu} = 36$ kA

- 3 and 4-pole Moulded Case Circuit Breakers
- $I_{cs} = I_{cu} = 36$  kA at 415 V AC
- $I_r$  can be set in steps  $(0.8-0.9-1.0) \times I_n$
- $I_f$  variable  $(5-6-7-8-9-10) \times I_n$
- Mounting screws and phase barriers in the scope of delivery



Poles	Rated current $I_n$	Overcurrent release $I_r$	Instant. release $I_f$	Article No.	Type	Packing
3	250 A	200-250 A	1250-2500	101454	Ex9M3S TM AC250 3P	1/2
3	315 A	252-315 A	1575-3150	101455	Ex9M3S TM AC315 3P	1/2
3	350 A	280-350 A	1750-3500	101456	Ex9M3S TM AC350 3P	1/2
3	400 A	320-400 A	2000-4000	101457	Ex9M3S TM AC400 3P	1/2
4	250 A	200-250 A	1250-2500	103174	Ex9M3S TM AC250 4P4T	1/2
4	315 A	252-315 A	1575-3150	103175	Ex9M3S TM AC315 4P4T	1/2
4	350 A	280-350 A	1750-3500	103176	Ex9M3S TM AC350 4P4T	1/2
4	400 A	320-400 A	2000-4000	103177	Ex9M3S TM AC400 4P4T	1/2

## Version Ex9M3N up to 400 A, $I_{cu} = 50$ kA

- 3 and 4-pole Moulded Case Circuit Breakers
- $I_{cs} = I_{cu} = 50$  kA at 415 V AC
- $I_r$  can be set in steps  $(0.8-0.9-1.0) \times I_n$
- $I_f$  variable  $(5-6-7-8-9-10) \times I_n$
- Mounting screws and phase barriers in the scope of delivery



Poles	Rated current $I_n$	Overcurrent release $I_r$	Instant. release $I_f$	Article No.	Type	Packing
3	250 A	200-250 A	1250-2500	101458	Ex9M3N TM AC250 3P	1/2
3	315 A	252-315 A	1575-3150	101459	Ex9M3N TM AC315 3P	1/2
3	350 A	280-350 A	1750-3500	101460	Ex9M3N TM AC350 3P	1/2
3	400 A	320-400 A	2000-4000	101461	Ex9M3N TM AC400 3P	1/2
4	250 A	200-250 A	1250-2500	103178	Ex9M3N TM AC250 4P4T	1/2
4	315 A	252-315 A	1575-3150	103179	Ex9M3N TM AC315 4P4T	1/2
4	350 A	280-350 A	1750-3500	103180	Ex9M3N TM AC350 4P4T	1/2
4	400 A	320-400 A	2000-4000	103181	Ex9M3N TM AC400 4P4T	1/2

# Moulded Case Circuit Breakers Ex9M3

## Version Ex9M3H up to 400 A, $I_{cu} = 100$ kA

- 3 and 4-pole Moulded Case Circuit Breakers
- $I_{cs} = I_{cu} = 100$  kA at 415 V AC
- $I_r$  can be set in steps  $(0.8-0.9-1.0) \times I_n$
- $I_i$  variable  $(5-6-7-8-9-10) \times I_n$
- Mounting screws and phase barriers in the scope of delivery



Poles	Rated current $I_n$	Overcurrent release $I_r$	Instant. release $I_i$	Article No.	Type	Packing
3	250 A	200-250 A	1250-2500	101470	Ex9M3H TM AC250 3P	1/2
3	315 A	252-315 A	1575-3150	101471	Ex9M3H TM AC315 3P	1/2
3	350 A	280-350 A	1750-3500	101472	Ex9M3H TM AC350 3P	1/2
3	400 A	320-400 A	2000-4000	101473	Ex9M3H TM AC400 3P	1/2
4	250 A	200-250 A	1250-2500	103190	Ex9M3H TM AC250 4P4T	1/2
4	315 A	252-315 A	1575-3150	103191	Ex9M3H TM AC315 4P4T	1/2
4	350 A	280-350 A	1750-3500	103192	Ex9M3H TM AC350 4P4T	1/2
4	400 A	320-400 A	2000-4000	103193	Ex9M3H TM AC400 4P4T	1/2

## Version Ex9M3P up to 400 A, $I_{cu} = 150$ kA

- 3 and 4-pole Moulded Case Circuit Breakers
- $I_{cs} = I_{cu} = 150$  kA at 415 V AC
- $I_r$  can be set in steps  $(0.8-0.9-1.0) \times I_n$
- $I_i$  variable  $(5-6-7-8-9-10) \times I_n$
- Mounting screws and phase barriers in the scope of delivery



Poles	Rated current $I_n$	Overcurrent release $I_r$	Instant. release $I_i$	Article No.	Type	Packing
3	250 A	200-250 A	1250-2500	101478	Ex9M3P TM AC250 3P	1/2
3	315 A	252-315 A	1575-3150	101479	Ex9M3P TM AC315 3P	1/2
3	350 A	280-350 A	1750-3500	101480	Ex9M3P TM AC350 3P	1/2
3	400 A	320-400 A	2000-4000	101481	Ex9M3P TM AC400 3P	1/2
4	250 A	200-250 A	1250-2500	103198	Ex9M3P TM AC250 4P4T	1/2
4	315 A	252-315 A	1575-3150	103199	Ex9M3P TM AC315 4P4T	1/2
4	350 A	280-350 A	1750-3500	103200	Ex9M3P TM AC350 4P4T	1/2
4	400 A	320-400 A	2000-4000	103201	Ex9M3P TM AC400 4P4T	1/2

# Moulded Case Circuit Breakers Ex9M4

## Version Ex9M4S up to 630 A, $I_{cu} = 36$ kA

- 3 and 4-pole Moulded Case Circuit Breakers
- $I_{cs} = I_{cu} = 36$  kA at 415 V AC
- $I_r$  can be set in steps  $(0.8-0.9-1.0) \times I_n$
- $I_i$  variable  $(5-6-7-8-9-10) \times I_n$
- Mounting screws and phase barriers in the scope of delivery



Poles	Rated current $I_n$	Overcurrent release $I_r$	Instant. release $I_i$	Article No.	Type	Packing
3	400 A	320-400 A	2000-4000	103373	Ex9M4S TM AC400 3P	1/1
3	500 A	400-500 A	2500-5000	103374	Ex9M4S TM AC500 3P	1/1
3	630 A	500-630 A	3150-6300	103375	Ex9M4S TM AC630 3P	1/1
4	400 A	320-400 A	2000-4000	103415	Ex9M4S TM AC400 4P4T	1/1
4	500 A	400-500 A	2500-5000	103416	Ex9M4S TM AC500 4P4T	1/1
4	630 A	500-630 A	3150-6300	103417	Ex9M4S TM AC630 4P4T	1/1

## Version Ex9M4N up to 630 A, $I_{cu} = 50$ kA

- 3 and 4-pole Moulded Case Circuit Breakers
- $I_{cs} = I_{cu} = 50$  kA at 415 V AC
- $I_r$  can be set in steps  $(0.8-0.9-1.0) \times I_n$
- $I_i$  variable  $(5-6-7-8-9-10) \times I_n$
- Mounting screws and phase barriers in the scope of delivery



Poles	Rated current $I_n$	Overcurrent release $I_r$	Instant. release $I_i$	Article No.	Type	Packing
3	400 A	320-400 A	2000-4000	103376	Ex9M4N TM AC400 3P	1/1
3	500 A	400-500 A	2500-5000	103377	Ex9M4N TM AC500 3P	1/1
3	630 A	500-630 A	3150-6300	103378	Ex9M4N TM AC630 3P	1/1
4	400 A	320-400 A	2000-4000	103418	Ex9M4N TM AC400 4P4T	1/1
4	500 A	400-500 A	2500-5000	103419	Ex9M4N TM AC500 4P4T	1/1
4	630 A	500-630 A	3150-6300	103420	Ex9M4N TM AC630 4P4T	1/1



# Moulded Case Circuit Breakers Ex9M4

## Version Ex9M4H up to 630 A, $I_{cu} = 100 \text{ kA}$

- 3 and 4-pole Moulded Case Circuit Breakers
- $I_{cs} = I_{cu} = 100 \text{ kA}$  at 415 V AC
- $I_r$  can be set in steps  $(0.8-0.9-1.0) \times I_n$
- $I_i$  variable  $(5-6-7-8-9-10) \times I_n$
- Mounting screws and phase barriers in the scope of delivery



Poles	Rated current $I_n$	Overcurrent release $I_r$	Instant. release $I_i$	Article No.	Type	Packing
3	400 A	320-400 A	2000-4000	103385	Ex9M4H TM AC400 3P	1/1
3	500 A	400-500 A	2500-5000	103386	Ex9M4H TM AC500 3P	1/1
3	630 A	500-630 A	3150-6300	103387	Ex9M4H TM AC630 3P	1/1
4	400 A	320-400 A	2000-4000	103427	Ex9M4H TM AC400 4P4T	1/1
4	500 A	400-500 A	2500-5000	103428	Ex9M4H TM AC500 4P4T	1/1
4	630 A	500-630 A	3150-6300	103429	Ex9M4H TM AC630 4P4T	1/1

## Version Ex9M4P up to 630 A, $I_{cu} = 150 \text{ kA}$

- 3 and 4-pole Moulded Case Circuit Breakers
- $I_{cs} = I_{cu} = 150 \text{ kA}$  at 415 V AC
- $I_r$  can be set in steps  $(0.8-0.9-1.0) \times I_n$
- $I_i$  variable  $(5-6-7-8-9-10) \times I_n$
- Mounting screws and phase barriers in the scope of delivery



Poles	Rated current $I_n$	Overcurrent release $I_r$	Instant. release $I_i$	Article No.	Type	Packing
3	400 A	320-400 A	2000-4000	103391	Ex9M4P TM AC400 3P	1/1
3	500 A	400-500 A	2500-5000	103392	Ex9M4P TM AC500 3P	1/1
3	630 A	500-630 A	3150-6300	103393	Ex9M4P TM AC630 3P	1/1
4	400 A	320-400 A	2000-4000	103433	Ex9M4P TM AC400 4P4T	1/1
4	500 A	400-500 A	2500-5000	103434	Ex9M4P TM AC500 4P4T	1/1
4	630 A	500-630 A	3150-6300	103435	Ex9M4P TM AC630 4P4T	1/1

# Moulded Case Circuit Breakers Ex9M5

## Version Ex9M5S up to 800 A, $I_{cu} = 36$ kA

- 3 and 4-pole Moulded Case Circuit Breakers
- $I_{cs} = I_{cu} = 36$  kA at 415 V AC
- $I_r$  can be set in steps  $(0.8-0.9-1.0) \times I_n$
- $I_i$  variable  $(5-6-7-8-9-10) \times I_n$
- Mounting screws and phase barriers in the scope of delivery



Poles	Rated current $I_n$	Overcurrent release $I_r$	Instant. release $I_i$	Article No.	Type	Packing
3	630 A	500-630 A	3150-6300	103394	Ex9M5S TM AC630 3P	1/1
3	700 A	560-700 A	3500-7000	103395	Ex9M5S TM AC700 3P	1/1
3	800 A	640-800 A	4000-8000	103396	Ex9M5S TM AC800 3P	1/1
4	630 A	500-630 A	3150-6300	103436	Ex9M5S TM AC630 4P4T	1/1
4	700 A	560-700 A	3500-7000	103437	Ex9M5S TM AC700 4P4T	1/1
4	800 A	640-800 A	4000-8000	103438	Ex9M5S TM AC800 4P4T	1/1

## Version Ex9M5N up to 800 A, $I_{cu} = 50$ kA

- 3 and 4-pole Moulded Case Circuit Breakers
- $I_{cs} = I_{cu} = 50$  kA at 415 V AC
- $I_r$  can be set in steps  $(0.8-0.9-1.0) \times I_n$
- $I_i$  variable  $(5-6-7-8-9-10) \times I_n$
- Mounting screws and phase barriers in the scope of delivery



Poles	Rated current $I_n$	Overcurrent release $I_r$	Instant. release $I_i$	Article No.	Type	Packing
3	630 A	500-630 A	3150-6300	103397	Ex9M5N TM AC630 3P	1/1
3	700 A	560-700 A	3500-7000	103398	Ex9M5N TM AC700 3P	1/1
3	800 A	640-800 A	4000-8000	103399	Ex9M5N TM AC800 3P	1/1
4	630 A	500-630 A	3150-6300	103439	Ex9M5N TM AC630 4P4T	1/1
4	700 A	560-700 A	3500-7000	103440	Ex9M5N TM AC700 4P4T	1/1
4	800 A	640-800 A	4000-8000	103441	Ex9M5N TM AC800 4P4T	1/1

# Moulded Case Circuit Breakers Ex9M5

## Version Ex9M5H up to 800 A, $I_{cu} = 100$ kA

- 3 and 4-pole Moulded Case Circuit Breakers
- $I_{cs} = I_{cu} = 100$  kA at 415 V AC
- $I_r$  can be set in steps  $(0.8-0.9-1.0) \times I_n$
- $I_i$  variable  $(5-6-7-8-9-10) \times I_n$
- Mounting screws and phase barriers in the scope of delivery



Poles	Rated current $I_n$	Overcurrent release $I_r$	Instant. release $I_i$	Article No.	Type	Packing
3	630 A	500-630 A	3150-6300	103406	Ex9M5H TM AC630 3P	1/1
3	700 A	560-700 A	3500-7000	103407	Ex9M5H TM AC700 3P	1/1
3	800 A	640-800 A	4000-8000	103408	Ex9M5H TM AC800 3P	1/1
4	630 A	500-630 A	3150-6300	103448	Ex9M5H TM AC630 4P4T	1/1
4	700 A	560-700 A	3500-7000	103449	Ex9M5H TM AC700 4P4T	1/1
4	800 A	640-800 A	4000-8000	103450	Ex9M5H TM AC800 4P4T	1/1

## Version Ex9M5P up to 800 A, $I_{cu} = 150$ kA

- 3 and 4-pole Moulded Case Circuit Breakers
- $I_{cs} = I_{cu} = 150$  kA at 415 V AC
- $I_r$  can be set in steps  $(0.8-0.9-1.0) \times I_n$
- $I_i$  variable  $(5-6-7-8-9-10) \times I_n$
- Mounting screws and phase barriers in the scope of delivery



Poles	Rated current $I_n$	Overcurrent release $I_r$	Instant. release $I_i$	Article No.	Type	Packing
3	630 A	500-630 A	3150-6300	103412	Ex9M5P TM AC630 3P	1/1
3	700 A	560-700 A	3500-7000	103413	Ex9M5P TM AC700 3P	1/1
3	800 A	640-800 A	4000-8000	103414	Ex9M5P TM AC800 3P	1/1
4	630 A	500-630 A	3150-6300	103454	Ex9M5P TM AC630 4P4T	1/1
4	700 A	560-700 A	3500-7000	103455	Ex9M5P TM AC700 4P4T	1/1
4	800 A	640-800 A	4000-8000	103456	Ex9M5P TM AC800 4P4T	1/1

# Notes

A large grid of dashed lines for taking notes, covering most of the page area below the header and above the footer.

# Electronic MCCBs Ex9M6



- Electronic Moulded Case Circuit Breakers
- Frame sizes M6
- Rated current up to 1600 A
- 3 and 4-pole versions
- Rated ultimate short circuit breaking capacity  $I_{cu}$  up to 100 kA
- Rated voltage 415 / 690 V AC
- Electronic release

Electronic Moulded Case Circuit Breakers Ex9M6 are intended for applications mainly in power distribution. Advantage of the electronic release is in an accuracy and reliability of the tripping contrary to the thermo-magnetic release. Testing according to IEC / EN 60947-2 standards ensures functions and reliability for wide variety of applications including isolation.

These breakers are offered with breaking capacities from 50 kA up to 100 kA. Rated impulse withstand voltage  $U_{imp}$  8 kV makes it possible to use them even in system with occurrences of transient overvoltage waves of high intensity, e.g. in heavy industry.

Utilization category B circuit breakers.

### Type Key

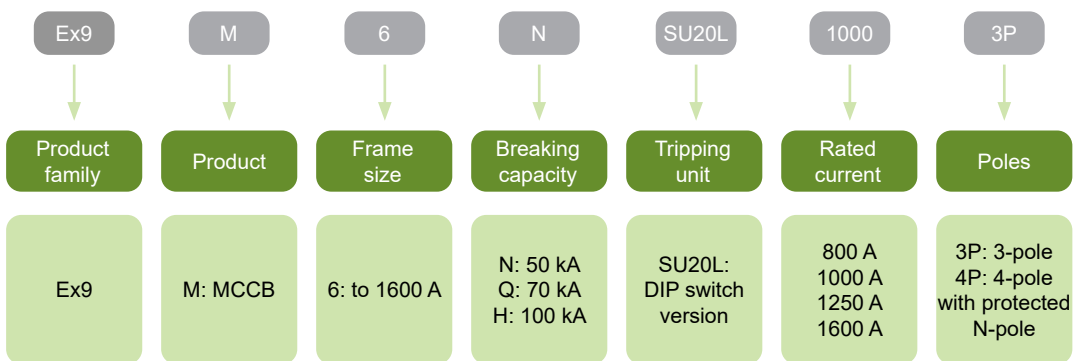

### Certification marks



# Electronic MCCBs Ex9M6

## Internal accessories

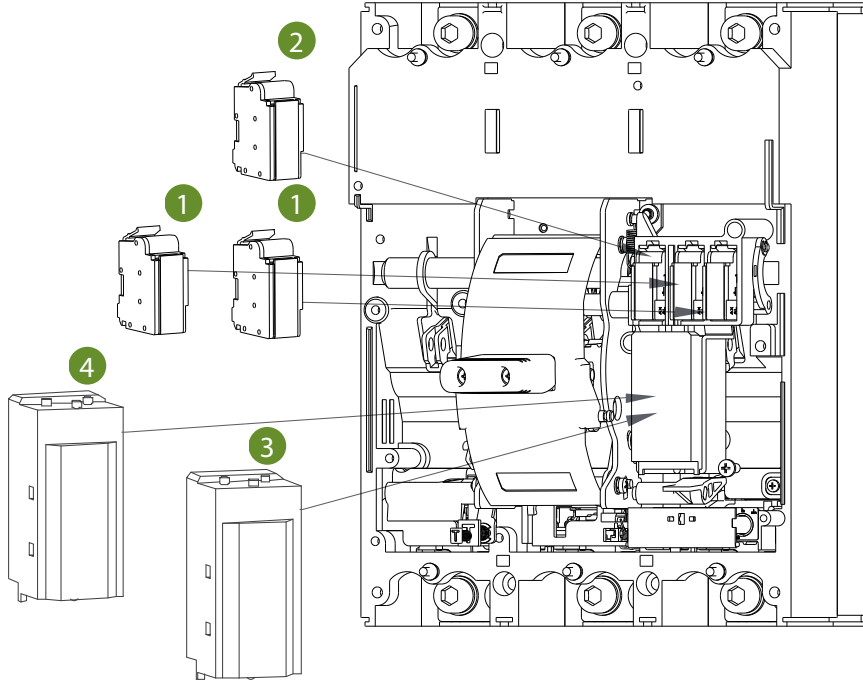

1

Auxiliary contact  
**AX21**  
up to 2 units

2

Signal contact  
**AL21**  
up to 1 unit

3

Shunt trip release  
**SHT26**  
1 unit or UVT26

4

Undervoltage release  
**UVT26**  
1 unit or SHT26

Auxiliary contact AX21

see page 68

Signal contact AL21

see page 68

Shunt trip releases SHT26

see page 68

Undervoltage releases UVT26

see page 68

# Electronic MCCBs Ex9M6

## External accessories

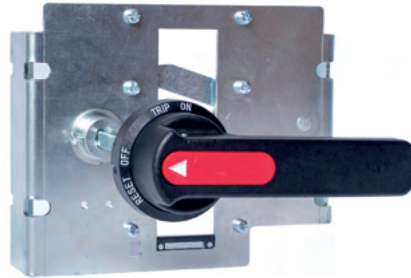

Extended rotary  
handle  
**ERH26**



Extended handle  
**LHD26**



Front connection  
plate  
**JP26**

Extended rotary handles ERH26

Extended handles LHD26

Front connection plate JP26

see page 69

see page 69

see page 69

# Electronic MCCBs Ex9M6

## Version Ex9M6N up to 1600 A, $I_{cu} = 50$ kA

- 3 and 4-pole Electronic Moulded Case Circuit Breakers
- $I_{cs} = I_{cu} = 50$  kA at 415 V AC
- $I_r$  can be set in steps (0.4-0.5-0.6-0.7-0.8-0.9-0.95-1.0)  $\times I_n$
- $I_i$  can be set in steps (2-3-4-6-8-10-12)  $\times I_n$
- Mounting screws and phase barriers in the scope of delivery



Poles	Rated current $I_n$	Overcurrent release $I_r$	Instant. release $I_i$	Article No.	Type	Packing
3	800 A	320—800 A	1600—9600 A	110340	Ex9M6N SU20L 800 3P	1/1
3	1000 A	400—1000 A	2000—12000 A	110341	Ex9M6N SU20L 1000 3P	1/1
3	1250 A	500—1250 A	2500—15000 A	110342	Ex9M6N SU20L 1250 3P	1/1
3	1600 A	640—1600 A	3200—19200 A	110343	Ex9M6N SU20L 1600 3P	1/1
4	800 A	320—800 A	1600—9600 A	110344	Ex9M6N SU20L 800 4P	1/1
4	1000 A	400—1000 A	2000—12000 A	110345	Ex9M6N SU20L 1000 4P	1/1
4	1250 A	500—1250 A	2500—15000 A	110346	Ex9M6N SU20L 1250 4P	1/1
4	1600 A	640—1600 A	3200—19200 A	110347	Ex9M6N SU20L 1600 4P	1/1

## Version Ex9M6Q up to 1600 A, $I_{cu} = 70$ kA

- 3 and 4-pole Electronic Moulded Case Circuit Breakers
- $I_{cs} = I_{cu} = 70$  kA at 415 V AC
- $I_r$  can be set in steps (0.4-0.5-0.6-0.7-0.8-0.9-0.95-1.0)  $\times I_n$
- $I_i$  can be set in steps (2-3-4-6-8-10-12)  $\times I_n$
- Mounting screws and phase barriers in the scope of delivery



Poles	Rated current $I_n$	Overcurrent release $I_r$	Instant. release $I_i$	Article No.	Type	Packing
3	800 A	320—800 A	1600—9600 A	110348	Ex9M6Q SU20L 800 3P	1/1
3	1000 A	400—1000 A	2000—12000 A	110349	Ex9M6Q SU20L 1000 3P	1/1
3	1250 A	500—1250 A	2500—15000 A	110350	Ex9M6Q SU20L 1250 3P	1/1
3	1600 A	640—1600 A	3200—19200 A	110351	Ex9M6Q SU20L 1600 3P	1/1
4	800 A	320—800 A	1600—9600 A	110352	Ex9M6Q SU20L 800 4P	1/1
4	1000 A	400—1000 A	2000—12000 A	110353	Ex9M6Q SU20L 1000 4P	1/1
4	1250 A	500—1250 A	2500—15000 A	110354	Ex9M6Q SU20L 1250 4P	1/1
4	1600 A	640—1600 A	3200—19200 A	110355	Ex9M6Q SU20L 1600 4P	1/1

## Version Ex9M6H up to 1600 A, $I_{cu} = 100$ kA

- 3 and 4-pole Electronic Moulded Case Circuit Breakers
- $I_{cs} = 70$  kA,  $I_{cu} = 100$  kA at 415 V AC
- $I_r$  can be set in steps (0.4-0.5-0.6-0.7-0.8-0.9-0.95-1.0)  $\times I_n$
- $I_i$  can be set in steps (2-3-4-6-8-10-12)  $\times I_n$
- Mounting screws and phase barriers in the scope of delivery



Poles	Rated current $I_n$	Overcurrent release $I_r$	Instant. release $I_i$	Article No.	Type	Packing
3	800 A	320—800 A	1600—9600 A	110356	Ex9M6H SU20L 800 3P	1/1
3	1000 A	400—1000 A	2000—12000 A	110357	Ex9M6H SU20L 1000 3P	1/1
3	1250 A	500—1250 A	2500—15000 A	110358	Ex9M6H SU20L 1250 3P	1/1
3	1600 A	640—1600 A	3200—19200 A	110359	Ex9M6H SU20L 1600 3P	1/1
4	800 A	320—800 A	1600—9600 A	110360	Ex9M6H SU20L 800 4P	1/1
4	1000 A	400—1000 A	2000—12000 A	110361	Ex9M6H SU20L 1000 4P	1/1
4	1250 A	500—1250 A	2500—15000 A	110362	Ex9M6H SU20L 1250 4P	1/1
4	1600 A	640—1600 A	3200—19200 A	110363	Ex9M6H SU20L 1600 4P	1/1

Technical data p. 90



# Electronic MCCBs Ex9M6 MOD



- Motor operated electronic Moulded Case Circuit Breakers
- Frame sizes M6
- Rated current up to 1600 A
- 3 and 4-pole versions
- Rated ultimate short circuit breaking capacity  $I_{cu}$  up to 100 kA
- Rated voltage 415 / 690 V AC
- Electronic release

Motor operated Electronic Moulded Case Circuit Breakers Ex9M6 MOD are intended for applications mainly in power distribution. Advantage of the electronic release is in an accuracy and reliability of the tripping contrary to the thermomagnetic release, as well as the remote control of the device. Testing according to IEC / EN 60947-2 standards ensures functions and reliability for wide variety of applications including isolation.

These breakers are offered with breaking capacities from 50 kA up to 100 kA. Rated impulse withstand voltage  $U_{imp}$  8 kV makes it possible to use them even in system with occurrences of transient overvoltage waves of high intensity, e.g. in heavy industry. This device is having a premounted closing release XF to allow the easy remote operation of the breaker.

Utilization category B circuit breakers.

### Type Key

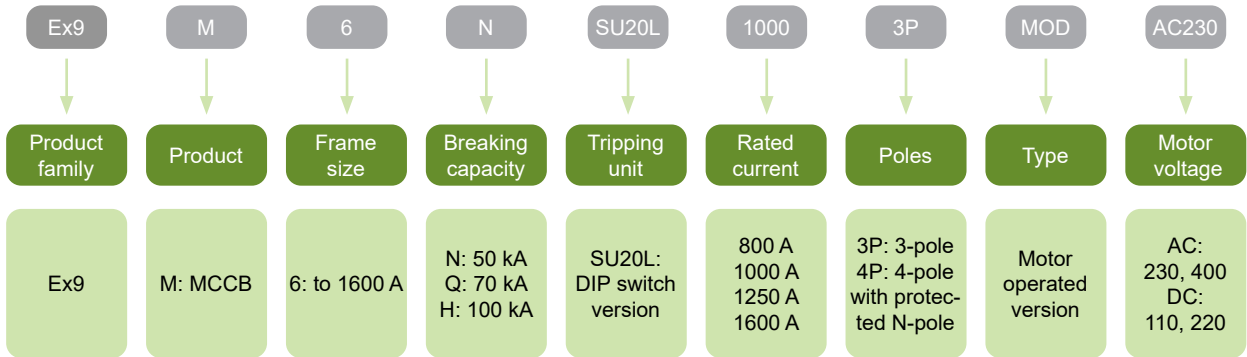

### Certification marks



# Electronic MCCBs Ex9M6 MOD

## Internal accessories

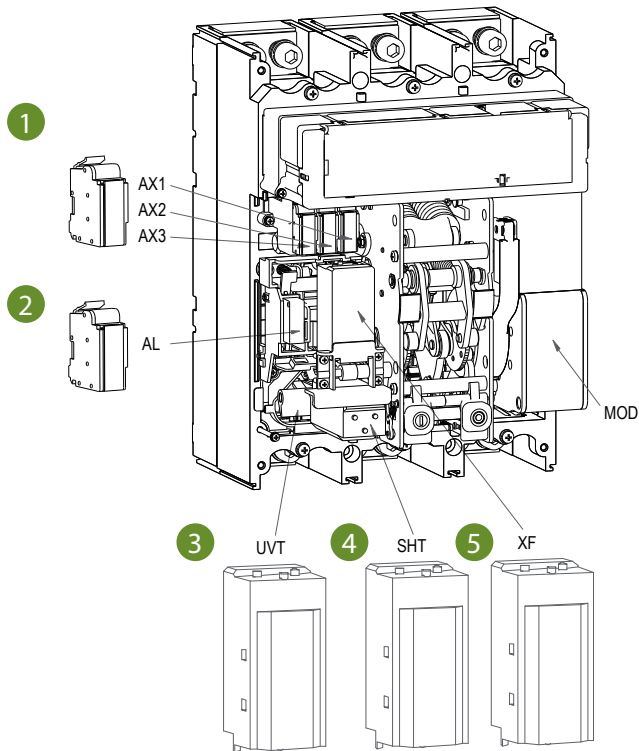

1

Auxiliary contact  
**AX21**  
up to 3 units

2

Signal contact  
**AL21**  
up to 1 unit

3

Undervoltage release  
**UVT26**  
1 unit or SHT26

4

Shunt trip release  
**SHT26**  
1 unit or UVT26

5

Closing release  
**XF26**

Auxiliary contact AX21

see page 68

Signal contact AL21

see page 68

Shunt trip releases SHT26

see page 68

Undervoltage releases UVT26

see page 68

Closing releases XF26

see page 26

# Electronic MCCBs Ex9M6 MOD

## External accessories



Front connection  
plate  
**JP26**

Front connection plate JP26

see page 69

# Electronic MCCBs Ex9M6 MOD

## Version Ex9M6N MOD AC230V up to 1600 A, $I_{cu} = 50$ kA

- 3 and 4-pole Electronic Moulded Case Circuit Breakers
- $I_{cs} = I_{cu} = 50$  kA at 415 V AC
- $I_r$  can be set in steps (0.4-0.5-0.6-0.7-0.8-0.9-0.95-1.0)  $\times I_n$
- $I_i$  can be set in steps (2-3-4-6-8-10-12)  $\times I_n$
- Mounting screws and phase barriers in the scope of delivery
- 2x AX, 1x AL, 1x SHT26, 1x XF26 with same operative voltage are pre-mounted (customizable under request)



Poles	Rated current $I_n$	Overcurrent release $I_r$	Instant. release $I_i$	Article No.	Type	Packing
3	800 A	320—800 A	1600—9600 A	110364	Ex9M6N SU20L 800 3P MOD AC230	1/1
3	1000 A	400—1000 A	2000—12000 A	110365	Ex9M6N SU20L 1000 3P MOD AC230	1/1
3	1250 A	500—1250 A	2500—15000 A	110366	Ex9M6N SU20L 1250 3P MOD AC230	1/1
3	1600 A	640—1600 A	3200—19200 A	110367	Ex9M6N SU20L 1600 3P MOD AC230	1/1
4	800 A	320—800 A	1600—9600 A	110368	Ex9M6N SU20L 800 4P MOD AC230	1/1
4	1000 A	400—1000 A	2000—12000 A	110369	Ex9M6N SU20L 1000 4P MOD AC230	1/1
4	1250 A	500—1250 A	2500—15000 A	110370	Ex9M6N SU20L 1250 4P MOD AC230	1/1
4	1600 A	640—1600 A	3200—19200 A	110371	Ex9M6N SU20L 1600 4P MOD AC230	1/1

## Version Ex9M6N MOD AC400V up to 1600 A, $I_{cu} = 50$ kA

- 3 and 4-pole Electronic Moulded Case Circuit Breakers
- $I_{cs} = I_{cu} = 50$  kA at 415 V AC
- $I_r$  can be set in steps (0.4-0.5-0.6-0.7-0.8-0.9-0.95-1.0)  $\times I_n$
- $I_i$  can be set in steps (2-3-4-6-8-10-12)  $\times I_n$
- Mounting screws and phase barriers in the scope of delivery
- 2x AX, 1x AL, 1x SHT26, 1x XF26 with same operative voltage are pre-mounted (customizable under request)



Poles	Rated current $I_n$	Overcurrent release $I_r$	Instant. release $I_i$	Article No.	Type	Packing
3	800 A	320—800 A	1600—9600 A	110372	Ex9M6N SU20L 800 3P MOD AC400	1/1
3	1000 A	400—1000 A	2000—12000 A	110373	Ex9M6N SU20L 1000 3P MOD AC400	1/1
3	1250 A	500—1250 A	2500—15000 A	110374	Ex9M6N SU20L 1250 3P MOD AC400	1/1
3	1600 A	640—1600 A	3200—19200 A	110375	Ex9M6N SU20L 1600 3P MOD AC400	1/1
4	800 A	320—800 A	1600—9600 A	110376	Ex9M6N SU20L 800 4P MOD AC400	1/1
4	1000 A	400—1000 A	2000—12000 A	110377	Ex9M6N SU20L 1000 4P MOD AC400	1/1
4	1250 A	500—1250 A	2500—15000 A	110378	Ex9M6N SU20L 1250 4P MOD AC400	1/1
4	1600 A	640—1600 A	3200—19200 A	110379	Ex9M6N SU20L 1600 4P MOD AC400	1/1

# Electronic MCCBs Ex9M6 MOD

## Version Ex9M6N MOD DC110V up to 1600 A, $I_{cu} = 50$ kA

- 3 and 4-pole Electronic Moulded Case Circuit Breakers
- $I_{cs} = I_{cu} = 50$  kA at 415 V AC
- $I_r$  can be set in steps (0.4-0.5-0.6-0.7-0.8-0.9-0.95-1.0)  $\times I_n$
- $I_i$  can be set in steps (2-3-4-6-8-10-12)  $\times I_n$
- Mounting screws and phase barriers in the scope of delivery
- 2x AX, 1x AL, 1x SHT26, 1x XF26 with same operative voltage are pre-mounted (customizable under request)



Poles	Rated current $I_n$	Overcurrent release $I_r$	Instant. release $I_i$	Article No.	Type	Packing
3	800 A	320—800 A	1600—9600 A	110380	Ex9M6N SU20L 800 3P MOD DC110	1/1
3	1000 A	400—1000 A	2000—12000 A	110381	Ex9M6N SU20L 1000 3P MOD DC110	1/1
3	1250 A	500—1250 A	2500—15000 A	110382	Ex9M6N SU20L 1250 3P MOD DC110	1/1
3	1600 A	640—1600 A	3200—19200 A	110383	Ex9M6N SU20L 1600 3P MOD DC110	1/1
4	800 A	320—800 A	1600—9600 A	110384	Ex9M6N SU20L 800 4P MOD DC110	1/1
4	1000 A	400—1000 A	2000—12000 A	110385	Ex9M6N SU20L 1000 4P MOD DC110	1/1
4	1250 A	500—1250 A	2500—15000 A	110386	Ex9M6N SU20L 1250 4P MOD DC110	1/1
4	1600 A	640—1600 A	3200—19200 A	110387	Ex9M6N SU20L 1600 4P MOD DC110	1/1

## Version Ex9M6N MOD DC220V up to 1600 A, $I_{cu} = 50$ kA

- 3 and 4-pole Electronic Moulded Case Circuit Breakers
- $I_{cs} = I_{cu} = 50$  kA at 415 V AC
- $I_r$  can be set in steps (0.4-0.5-0.6-0.7-0.8-0.9-0.95-1.0)  $\times I_n$
- $I_i$  can be set in steps (2-3-4-6-8-10-12)  $\times I_n$
- Mounting screws and phase barriers in the scope of delivery
- 2x AX, 1x AL, 1x SHT26, 1x XF26 with same operative voltage are pre-mounted (customizable under request)



Poles	Rated current $I_n$	Overcurrent release $I_r$	Instant. release $I_i$	Article No.	Type	Packing
3	800 A	320—800 A	1600—9600 A	110388	Ex9M6N SU20L 800 3P MOD DC220	1/1
3	1000 A	400—1000 A	2000—12000 A	110389	Ex9M6N SU20L 1000 3P MOD DC220	1/1
3	1250 A	500—1250 A	2500—15000 A	110390	Ex9M6N SU20L 1250 3P MOD DC220	1/1
3	1600 A	640—1600 A	3200—19200 A	110391	Ex9M6N SU20L 1600 3P MOD DC220	1/1
4	800 A	320—800 A	1600—9600 A	110392	Ex9M6N SU20L 800 4P MOD DC220	1/1
4	1000 A	400—1000 A	2000—12000 A	110393	Ex9M6N SU20L 1000 4P MOD DC220	1/1
4	1250 A	500—1250 A	2500—15000 A	110394	Ex9M6N SU20L 1250 4P MOD DC220	1/1
4	1600 A	640—1600 A	3200—19200 A	110395	Ex9M6N SU20L 1600 4P MOD DC220	1/1

# Electronic MCCBs Ex9M6 MOD

## Version Ex9M6Q MOD AC230V up to 1600 A, $I_{cu} = 70$ kA

- 3 and 4-pole Electronic Moulded Case Circuit Breakers
- $I_{cs} = I_{cu} = 70$  kA at 415 V AC
- $I_r$  can be set in steps (0.4-0.5-0.6-0.7-0.8-0.9-0.95-1.0)  $\times I_n$
- $I_i$  can be set in steps (2-3-4-6-8-10-12)  $\times I_n$
- Mounting screws and phase barriers in the scope of delivery
- 2x AX, 1x AL, 1x SHT26, 1x XF26 with same operative voltage are pre-mounted (customizable under request)



Poles	Rated current $I_n$	Overcurrent release $I_r$	Instant. release $I_i$	Article No.	Type	Packing
3	800 A	320—800 A	1600—9600 A	110396	Ex9M6Q SU20L 800 3P MOD AC230	1/1
3	1000 A	400—1000 A	2000—12000 A	110397	Ex9M6Q SU20L 1000 3P MOD AC230	1/1
3	1250 A	500—1250 A	2500—15000 A	110398	Ex9M6Q SU20L 1250 3P MOD AC230	1/1
3	1600 A	640—1600 A	3200—19200 A	110399	Ex9M6Q SU20L 1600 3P MOD AC230	1/1
4	800 A	320—800 A	1600—9600 A	110400	Ex9M6Q SU20L 800 4P MOD AC230	1/1
4	1000 A	400—1000 A	2000—12000 A	110401	Ex9M6Q SU20L 1000 4P MOD AC230	1/1
4	1250 A	500—1250 A	2500—15000 A	110402	Ex9M6Q SU20L 1250 4P MOD AC230	1/1
4	1600 A	640—1600 A	3200—19200 A	110403	Ex9M6Q SU20L 1600 4P MOD AC230	1/1

## Version Ex9M6Q MOD AC400V up to 1600 A, $I_{cu} = 70$ kA

- 3 and 4-pole Electronic Moulded Case Circuit Breakers
- $I_{cs} = I_{cu} = 70$  kA at 415 V AC
- $I_r$  can be set in steps (0.4-0.5-0.6-0.7-0.8-0.9-0.95-1.0)  $\times I_n$
- $I_i$  can be set in steps (2-3-4-6-8-10-12)  $\times I_n$
- Mounting screws and phase barriers in the scope of delivery
- 2x AX, 1x AL, 1x SHT26, 1x XF26 with same operative voltage are pre-mounted (customizable under request)



Poles	Rated current $I_n$	Overcurrent release $I_r$	Instant. release $I_i$	Article No.	Type	Packing
3	800 A	320—800 A	1600—9600 A	110404	Ex9M6Q SU20L 800 3P MOD AC400	1/1
3	1000 A	400—1000 A	2000—12000 A	110405	Ex9M6Q SU20L 1000 3P MOD AC400	1/1
3	1250 A	500—1250 A	2500—15000 A	110406	Ex9M6Q SU20L 1250 3P MOD AC400	1/1
3	1600 A	640—1600 A	3200—19200 A	110407	Ex9M6Q SU20L 1600 3P MOD AC400	1/1
4	800 A	320—800 A	1600—9600 A	110408	Ex9M6Q SU20L 800 4P MOD AC400	1/1
4	1000 A	400—1000 A	2000—12000 A	110409	Ex9M6Q SU20L 1000 4P MOD AC400	1/1
4	1250 A	500—1250 A	2500—15000 A	110410	Ex9M6Q SU20L 1250 4P MOD AC400	1/1
4	1600 A	640—1600 A	3200—19200 A	110411	Ex9M6Q SU20L 1600 4P MOD AC400	1/1

# Electronic MCCBs Ex9M6 MOD

## Version Ex9M6Q MOD DC110V up to 1600 A, $I_{cu} = 70$ kA

- 3 and 4-pole Electronic Moulded Case Circuit Breakers
- $I_{cs} = I_{cu} = 70$  kA at 415 V AC
- $I_r$  can be set in steps (0.4-0.5-0.6-0.7-0.8-0.9-0.95-1.0)  $\times I_n$
- $I_i$  can be set in steps (2-3-4-6-8-10-12)  $\times I_n$
- Mounting screws and phase barriers in the scope of delivery
- 2x AX, 1x AL, 1x SHT26, 1x XF26 with same operative voltage are pre-mounted (customizable under request)



Poles	Rated current $I_n$	Overcurrent release $I_r$	Instant. release $I_i$	Article No.	Type	Packing
3	800 A	320—800 A	1600—9600 A	110412	Ex9M6Q SU20L 800 3P MOD DC110	1/1
3	1000 A	400—1000 A	2000—12000 A	110413	Ex9M6Q SU20L 1000 3P MOD DC110	1/1
3	1250 A	500—1250 A	2500—15000 A	110414	Ex9M6Q SU20L 1250 3P MOD DC110	1/1
3	1600 A	640—1600 A	3200—19200 A	110415	Ex9M6Q SU20L 1600 3P MOD DC110	1/1
4	800 A	320—800 A	1600—9600 A	110416	Ex9M6Q SU20L 800 4P MOD DC110	1/1
4	1000 A	400—1000 A	2000—12000 A	110417	Ex9M6Q SU20L 1000 4P MOD DC110	1/1
4	1250 A	500—1250 A	2500—15000 A	110418	Ex9M6Q SU20L 1250 4P MOD DC110	1/1
4	1600 A	640—1600 A	3200—19200 A	110419	Ex9M6Q SU20L 1600 4P MOD DC110	1/1

## Version Ex9M6Q MOD DC220V up to 1600 A, $I_{cu} = 70$ kA

- 3 and 4-pole Electronic Moulded Case Circuit Breakers
- $I_{cs} = I_{cu} = 70$  kA at 415 V AC
- $I_r$  can be set in steps (0.4-0.5-0.6-0.7-0.8-0.9-0.95-1.0)  $\times I_n$
- $I_i$  can be set in steps (2-3-4-6-8-10-12)  $\times I_n$
- Mounting screws and phase barriers in the scope of delivery
- 2x AX, 1x AL, 1x SHT26, 1x XF26 with same operative voltage are pre-mounted (customizable under request)



Poles	Rated current $I_n$	Overcurrent release $I_r$	Instant. release $I_i$	Article No.	Type	Packing
3	800 A	320—800 A	1600—9600 A	110420	Ex9M6Q SU20L 800 3P MOD DC220	1/1
3	1000 A	400—1000 A	2000—12000 A	110421	Ex9M6Q SU20L 1000 3P MOD DC220	1/1
3	1250 A	500—1250 A	2500—15000 A	110422	Ex9M6Q SU20L 1250 3P MOD DC220	1/1
3	1600 A	640—1600 A	3200—19200 A	110423	Ex9M6Q SU20L 1600 3P MOD DC220	1/1
4	800 A	320—800 A	1600—9600 A	110424	Ex9M6Q SU20L 800 4P MOD DC220	1/1
4	1000 A	400—1000 A	2000—12000 A	110425	Ex9M6Q SU20L 1000 4P MOD DC220	1/1
4	1250 A	500—1250 A	2500—15000 A	110426	Ex9M6Q SU20L 1250 4P MOD DC220	1/1
4	1600 A	640—1600 A	3200—19200 A	110427	Ex9M6Q SU20L 1600 4P MOD DC220	1/1

# Electronic MCCBs Ex9M6 MOD

## Version Ex9M6H MOD AC230V up to 1600 A, $I_{cu} = 100$ kA

- 3 and 4-pole Electronic Moulded Case Circuit Breakers
- $I_{cs} = 70$  kA  $I_{cu} = 100$  kA at 415 V AC
- $I_r$  can be set in steps (0.4-0.5-0.6-0.7-0.8-0.9-0.95-1.0)  $\times I_n$
- $I_i$  can be set in steps (2-3-4-6-8-10-12)  $\times I_n$
- Mounting screws and phase barriers in the scope of delivery
- 2x AX, 1x AL, 1x SHT26, 1x XF26 with same operative voltage are pre-mounted (customizable under request)



Poles	Rated current $I_n$	Overcurrent release $I_r$	Instant. release $I_i$	Article No.	Type	Packing
3	800 A	320—800 A	1600—9600 A	110428	Ex9M6H SU20L 800 3P MOD AC230	1/1
3	1000 A	400—1000 A	2000—12000 A	110429	Ex9M6H SU20L 1000 3P MOD AC230	1/1
3	1250 A	500—1250 A	2500—15000 A	110430	Ex9M6H SU20L 1250 3P MOD AC230	1/1
3	1600 A	640—1600 A	3200—19200 A	110431	Ex9M6H SU20L 1600 3P MOD AC230	1/1
4	800 A	320—800 A	1600—9600 A	110432	Ex9M6H SU20L 800 4P MOD AC230	1/1
4	1000 A	400—1000 A	2000—12000 A	110433	Ex9M6H SU20L 1000 4P MOD AC230	1/1
4	1250 A	500—1250 A	2500—15000 A	110434	Ex9M6H SU20L 1250 4P MOD AC230	1/1
4	1600 A	640—1600 A	3200—19200 A	110435	Ex9M6H SU20L 1600 4P MOD AC230	1/1

## Version Ex9M6H MOD AC400V up to 1600 A, $I_{cu} = 100$ kA

- 3 and 4-pole Electronic Moulded Case Circuit Breakers
- $I_{cs} = 70$  kA  $I_{cu} = 100$  kA at 415 V AC
- $I_r$  can be set in steps (0.4-0.5-0.6-0.7-0.8-0.9-0.95-1.0)  $\times I_n$
- $I_i$  can be set in steps (2-3-4-6-8-10-12)  $\times I_n$
- Mounting screws and phase barriers in the scope of delivery
- 2x AX, 1x AL, 1x SHT26, 1x XF26 with same operative voltage are pre-mounted (customizable under request)



Poles	Rated current $I_n$	Overcurrent release $I_r$	Instant. release $I_i$	Article No.	Type	Packing
3	800 A	320—800 A	1600—9600 A	110436	Ex9M6H SU20L 800 3P MOD AC400	1/1
3	1000 A	400—1000 A	2000—12000 A	110437	Ex9M6H SU20L 1000 3P MOD AC400	1/1
3	1250 A	500—1250 A	2500—15000 A	110438	Ex9M6H SU20L 1250 3P MOD AC400	1/1
3	1600 A	640—1600 A	3200—19200 A	110439	Ex9M6H SU20L 1600 3P MOD AC400	1/1
4	800 A	320—800 A	1600—9600 A	110440	Ex9M6H SU20L 800 4P MOD AC400	1/1
4	1000 A	400—1000 A	2000—12000 A	110441	Ex9M6H SU20L 1000 4P MOD AC400	1/1
4	1250 A	500—1250 A	2500—15000 A	110442	Ex9M6H SU20L 1250 4P MOD AC400	1/1
4	1600 A	640—1600 A	3200—19200 A	110443	Ex9M6H SU20L 1600 4P MOD AC400	1/1



# Electronic MCCBs Ex9M6 MOD

## Version Ex9M6H MOD DC110V up to 1600 A, $I_{cu} = 100$ kA

- 3 and 4-pole Electronic Moulded Case Circuit Breakers
- $I_{cs} = 70$  kA  $I_{cu} = 100$  kA at 415 V AC
- $I_r$  can be set in steps (0.4-0.5-0.6-0.7-0.8-0.9-0.95-1.0)  $\times I_n$
- $I_i$  can be set in steps (2-3-4-6-8-10-12)  $\times I_n$
- Mounting screws and phase barriers in the scope of delivery
- 2x AX, 1x AL, 1x SHT26, 1x XF26 with same operative voltage are pre-mounted (customizable under request)



Poles	Rated current $I_n$	Overcurrent release $I_r$	Instant. release $I_i$	Article No.	Type	Packing
3	800 A	320—800 A	1600—9600 A	110444	Ex9M6H SU20L 800 3P MOD DC110	1/1
3	1000 A	400—1000 A	2000—12000 A	110445	Ex9M6H SU20L 1000 3P MOD DC110	1/1
3	1250 A	500—1250 A	2500—15000 A	110446	Ex9M6H SU20L 1250 3P MOD DC110	1/1
3	1600 A	640—1600 A	3200—19200 A	110447	Ex9M6H SU20L 1600 3P MOD DC110	1/1
4	800 A	320—800 A	1600—9600 A	110448	Ex9M6H SU20L 800 4P MOD DC110	1/1
4	1000 A	400—1000 A	2000—12000 A	110449	Ex9M6H SU20L 1000 4P MOD DC110	1/1
4	1250 A	500—1250 A	2500—15000 A	110450	Ex9M6H SU20L 1250 4P MOD DC110	1/1
4	1600 A	640—1600 A	3200—19200 A	110451	Ex9M6H SU20L 1600 4P MOD DC110	1/1

## Version Ex9M6H MOD DC220V up to 1600 A, $I_{cu} = 100$ kA

- 3 and 4-pole Electronic Moulded Case Circuit Breakers
- $I_{cs} = 70$  kA  $I_{cu} = 100$  kA at 415 V AC
- $I_r$  can be set in steps (0.4-0.5-0.6-0.7-0.8-0.9-0.95-1.0)  $\times I_n$
- $I_i$  can be set in steps (2-3-4-6-8-10-12)  $\times I_n$
- Mounting screws and phase barriers in the scope of delivery
- 2x AX, 1x AL, 1x SHT26, 1x XF26 with same operative voltage are pre-mounted (customizable under request)



Poles	Rated current $I_n$	Overcurrent release $I_r$	Instant. release $I_i$	Article No.	Type	Packing
3	800 A	320—800 A	1600—9600 A	110452	Ex9M6H SU20L 800 3P MOD DC220	1/1
3	1000 A	400—1000 A	2000—12000 A	110453	Ex9M6H SU20L 1000 3P MOD DC220	1/1
3	1250 A	500—1250 A	2500—15000 A	110454	Ex9M6H SU20L 1250 3P MOD DC220	1/1
3	1600 A	640—1600 A	3200—19200 A	110455	Ex9M6H SU20L 1600 3P MOD DC220	1/1
4	800 A	320—800 A	1600—9600 A	110456	Ex9M6H SU20L 800 4P MOD DC220	1/1
4	1000 A	400—1000 A	2000—12000 A	110457	Ex9M6H SU20L 1000 4P MOD DC220	1/1
4	1250 A	500—1250 A	2500—15000 A	110458	Ex9M6H SU20L 1250 4P MOD DC220	1/1
4	1600 A	640—1600 A	3200—19200 A	110459	Ex9M6H SU20L 1600 4P MOD DC220	1/1

# Notes

A large grid of dashed lines for taking notes, consisting of approximately 25 columns and 35 rows.

# MCCB Switch Disconnectors Ex9MSD



- MCCB Switch Disconnectors
- Frame sizes M1 - M5
- Rated current up to 800 A
- Tested according to EN 60947-3
- AC current character
- 3 and 4-poles versions
- Rated operating voltage Ue up to 690 V AC
- Fixed version

AC versions of MCCB based Switch Disconnectors Ex9MSD are used as a main switch in many various circuits. They are intended primarily for applications in power distribution.

These switch disconnectors have same size and design as standard Ex9M MCCBs. Therefore there is the possibility to use fully compatible range of external and internal accessories including extended rotary handles, auxiliary contacts, tripping units, motor operators and terminal covers.

## Type Key

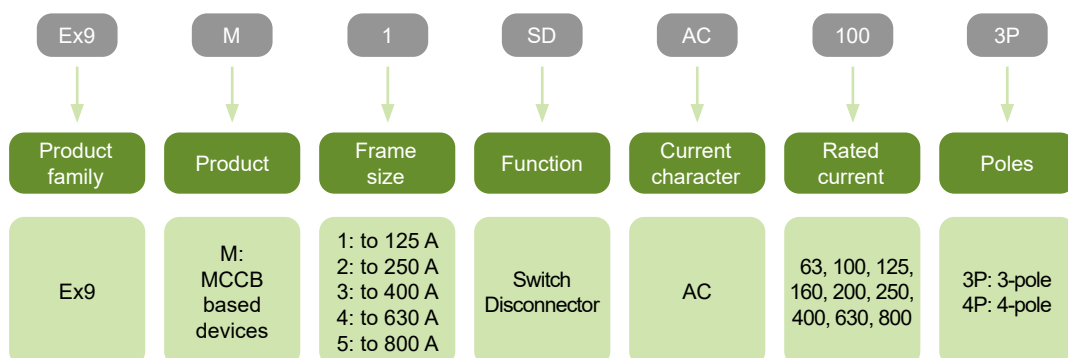

## Certification marks



# MCCB Switch Disconnectors Ex9MSD

## Internal accessories

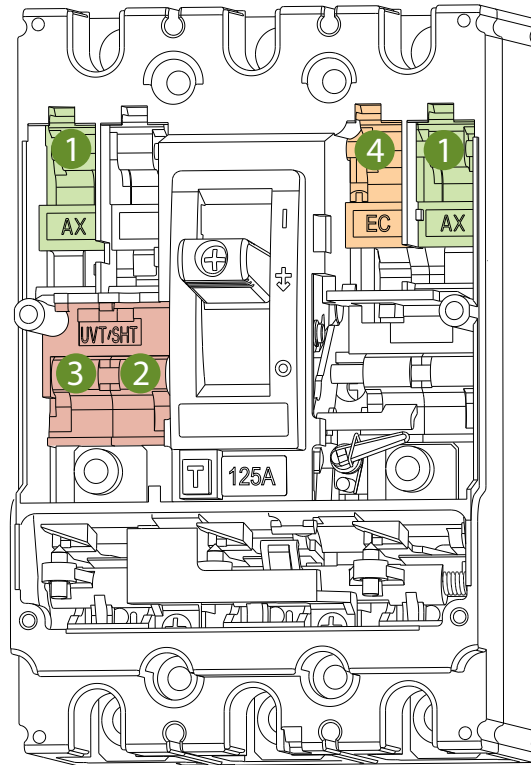

1

Auxiliary contact  
**AX21**

2

Shunt trip release  
**SHT2i**  
1 unit or UVT2i

3

Undervoltage release  
**UVT2i**  
1 unit or SHT2i

4

Early-make  
auxiliary contact  
**EC 2i**

Auxiliary contact AX21

Shunt trip releases SHT2i

Undervoltage releases UVT2i

Early-make auxiliary contact EC 2i

see page 62

see page 62

see page 63

see page 62

All internal accessories for the frame sizes M2+M3 and M4+M5 are identical.

# MCCB Switch Disconnectors Ex9MSD

## External accessories



Phase barriers  
**PB2i**



Terminal cover, short  
**TCV2i**



Terminal cover, long  
**TCE2i**



Box terminals  
**MC2i**



Tunnel terminals  
**MC2i W**



Mounting depth spacers  
**WG i**



Remote operator  
**MOD2i**



Direct rotary handle  
**RHD2i**



Extended rotary handle  
**ERH2i**

Phase barriers PB2i

Terminal cover, short TCV2i

Terminal cover, long TCE2i

Remote operators MOD2i

Direct rotary handles RHD2i

Extended rotary handles ERH2i

Connection terminals MC2i

Mounting depth spacers WG i

see page 64

see page 65

see page 66

see page 63

see page 64

see page 64

see page 65

see page 66

# MCCB Switch Disconnectors Ex9MSD

## 3-pole versions

- M1 and M2 frame size devices are delivered with box terminals, M3/M4/M5 with screw terminals
- Mounting screws as well as phase barriers in the scope of delivery



Rated current $I_n$	Frame size	Article No.	Type	Packing
63 A	M1	103044	Ex9M1SD AC63 3P	1/8
100 A	M1	103045	Ex9M1SD AC100 3P	1/8
125 A	M1	103046	Ex9M1SD AC125 3P	1/8
125 A	M2	103050	Ex9M2SD AC125 3P	1/4
160 A	M2	103051	Ex9M2SD AC160 3P	1/4
200 A	M2	103052	Ex9M2SD AC200 3P	1/4
250 A	M2	103053	Ex9M2SD AC250 3P	1/4
250 A	M3	103058	Ex9M3SD AC250 3P	1/2
400 A	M3	103059	Ex9M3SD AC400 3P	1/2
630 A	M4	104016	Ex9M4SD AC630 3P	1
800 A	M5	104018	Ex9M5SD AC800 3P	1

## 4-pole versions

- M1 and M2 frame size devices are delivered with box terminals, M3/M4/M5 with screw terminals
- Mounting screws as well as phase barriers in the scope of delivery



Rated current $I_n$	Frame size	Article No.	Type	Packing
63 A	M1	103047	Ex9M1SD AC63 4P	1/8
100 A	M1	103048	Ex9M1SD AC100 4P	1/8
125 A	M1	103049	Ex9M1SD AC125 4P	1/8
125 A	M2	103054	Ex9M2SD AC125 4P	1/4
160 A	M2	103055	Ex9M2SD AC160 4P	1/4
200 A	M2	103056	Ex9M2SD AC200 4P	1/4
250 A	M2	103057	Ex9M2SD AC250 4P	1/4
250 A	M3	103060	Ex9M3SD AC250 4P	1/2
400 A	M3	103061	Ex9M3SD AC400 4P	1/2
630 A	M4	104017	Ex9M4SD AC630 4P	1
800 A	M5	104019	Ex9M5SD AC800 4P	1

# MCCB Switch Disconnectors Ex9M6SD



- Moulded Case Switch Disconnectors
- Tested according to IEC/EN 60947-3
- Frame sizes M6
- Rated current up to 1600 A
- 3 and 4-pole versions
- Rated voltage 415 / 690 V AC

AC versions of Moulded Case Switch Disconnectors Ex9M6SD are intended for applications mainly in power distribution as a main switch in a wide variety of circuits.

These devices has the same frame size than the electronic MCCB Ex9M6, which allows the possibility of using the full range of accessories available for such MCCB.

Testing the Ex9M6SD according to IEC / EN 60947-3 standards ensures reliability for wide variety of applications including isolation.

## Type Key

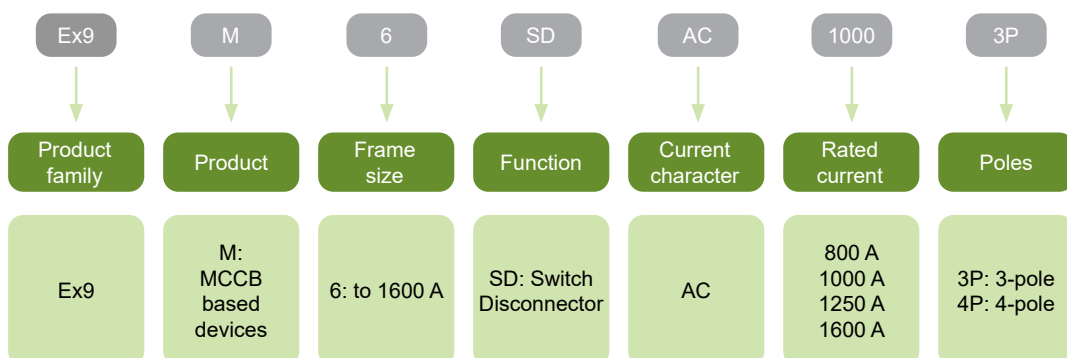

## Certification marks



# MCCB Switch Disconnectors Ex9M6SD

## Internal accessories

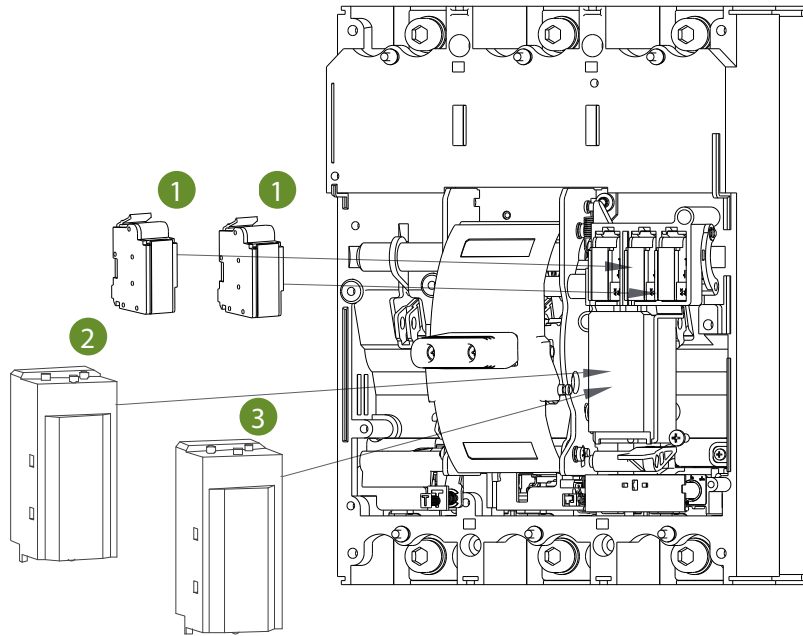

1

Auxiliary contact  
**AX21**  
up to 2 units

2

Shunt trip release  
**SHT26**  
1 unit or UVT26

3

Undervoltage release  
**UVT26**  
1 unit or SHT26

Auxiliary contact AX21

see page 68

Shunt trip releases SHT26

see page 68

Undervoltage releases UVT26

see page 68



# MCCB Switch Disconnectors Ex9M6SD

## External accessories

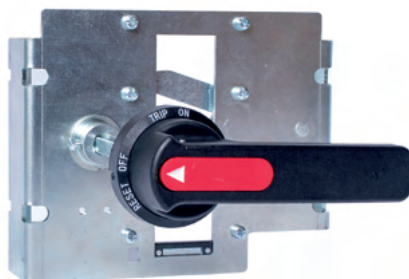

Extended rotatory handle  
**ERH26**



Extended handle  
**LHD26**



Front connection plate  
**JP26**

Extended rotary handles ERH26

Extended handles LHD26

Front connection plate JP26

see page 69

see page 69

see page 69

# MCCB Switch Disconnectors Ex9M6SD

## Switch disconnector size M6 up to 1600 A

- 3 and 4-pole Moulded Case Switch disconnectors
- Mounting screws and phase barriers in the scope of delivery



Poles	Rated current	Article No.	Type	Packing
3	800 A	110478	Ex9M6SD AC800 3P	1/1
3	1000 A	110479	Ex9M6SD AC1000 3P	1/1
3	1250 A	110480	Ex9M6SD AC1250 3P	1/1
3	1600 A	110481	Ex9M6SD AC1600 3P	1/1
4	800 A	110482	Ex9M6SD AC800 4P	1/1
4	1000 A	110483	Ex9M6SD AC1000 4P	1/1
4	1250 A	110484	Ex9M6SD AC1250 4P	1/1
4	1600 A	110485	Ex9M6SD AC1600 4P	1/1

# DC MCCBs Ex9MD



- DC Moulded Case Circuit Breakers
- Frame sizes M1 - M5
- Rated current up to 800 A
- 3 and 4-pole versions
- Rated ultimate short circuit breaking capacity  $I_{cu}$  up to 100 kA,  $I_{cs} = 100 \% I_{cu}$
- Rated voltage 750 V DC (3-pole) and 1000 V DC (4-pole)
- Thermomagnetic releases
- Fixed version

DC Moulded Case Circuit Breakers Ex9MD TM are intended mainly for photovoltaic applications. Testing according to IEC / EN 60947-2 standards ensures functions and reliability for wide variety of applications including isolation.

These breakers are offered with breaking capacities from 25 kA up to 100 kA. Rated impulse withstand voltage  $U_{imp}$  8 kV makes it possible to use them even in systems with occurrences of transient overvoltage waves of high intensity.

Utilization category A.

## Type Key

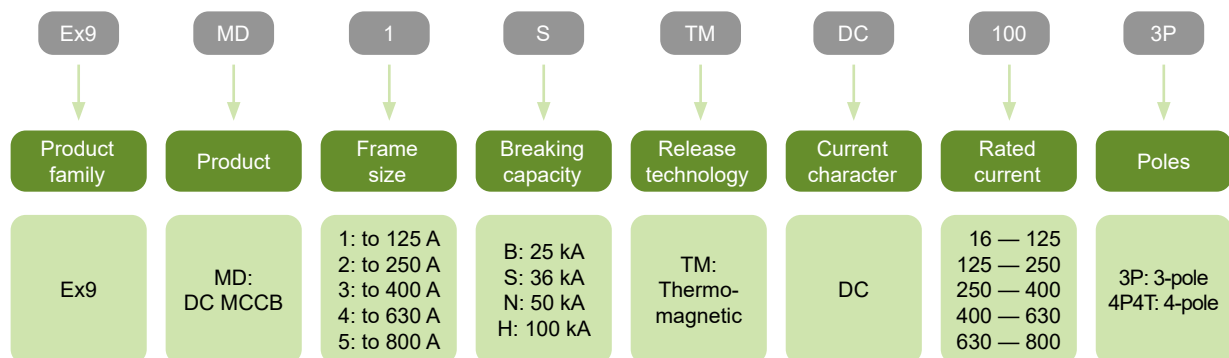

## Certification marks



# DC MCCBs Ex9MD

## Internal accessories

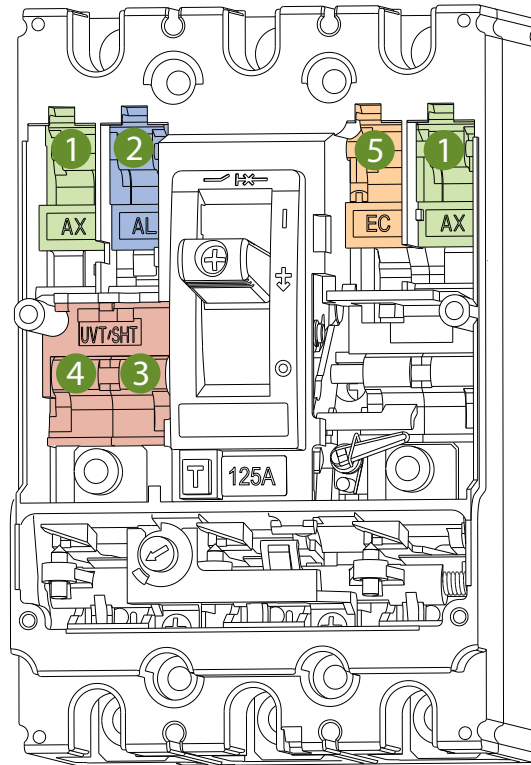

1

Auxiliary contact  
**AX21**

2

Signal contact  
**AL21**

3

Shunt trip release  
**SHT2i**  
1 unit or UVT2i

4

Undervoltage release  
**UVT2i**  
1 unit or SHT2i

5

Early-make  
auxiliary contact  
**EC 2i**

Auxiliary contact AX21

see page 62

Signal contact AL21

see page 62

Shunt trip releases SHT2i

see page 62

Undervoltage releases UVT2i

see page 63

Early-make auxiliary contact EC 2i

see page 62

All internal accessories for the frame sizes M2+M3 and M4+M5 are identical.

The undervoltage release UVT in PV system is intended e.g. for safe remote disconnection of DC part from installation.

# DC MCCBs Ex9MD

## External accessories



Phase barriers  
**PB2i**



Terminal cover, short  
**TCV2i**



Terminal cover, long  
**TCE2i**



Box terminals  
**MC2i**



Tunnel terminals  
**MC2i W**



Mounting depth spacers  
**WG i**



Remote operator  
**MOD2i**



Direct rotary handle  
**RHD2i**



Extended rotary handle  
**ERH2i**

Phase barriers PB2i

Terminal cover, short TCV2i

Terminal cover, long TCE2i

Remote operators MOD2i

Direct rotary handles RHD2i

Extended rotary handles ERH2i

Connection terminals MC2i

Mounting depth spacers WG i

see page 64

see page 65

see page 66

see page 63

see page 64

see page 64

see page 65

see page 66

# DC MCCBs Ex9MD1 up to 125 A

## Version Ex9MD1B, $I_{cu} = 25 \text{ kA}$

- DC Moulded Case Circuit Breakers
- 3 and 4-pole versions
- $I_{cs} = I_{cu} = 25 \text{ kA}$  at 750/1000 V DC
- $I_r$  can be set in steps  $(0.8-0.9-1.0) \times I_n$
- $I_i$  fixed as  $10 \times I_n$
- Mounting screws, interconnection busbars as well as phase barriers in the scope of delivery



Rated current $I_n$	Overcurrent release $I_r$	Instant. release $I_i$	Article No.	Type	Packing
16 A	12.8—16 A	160 A	101768	Ex9MD1B TM DC16 3P	1/8
20 A	16—20 A	200 A	101769	Ex9MD1B TM DC20 3P	1/8
25 A	20—25 A	250 A	101770	Ex9MD1B TM DC25 3P	1/8
32 A	25.6—32 A	320 A	101771	Ex9MD1B TM DC32 3P	1/8
40 A	32—40 A	400 A	101772	Ex9MD1B TM DC40 3P	1/8
50 A	40—50 A	500 A	101773	Ex9MD1B TM DC50 3P	1/8
63 A	50.4—63 A	630 A	101774	Ex9MD1B TM DC63 3P	1/8
80 A	64—80 A	800 A	101775	Ex9MD1B TM DC80 3P	1/8
100 A	80—100 A	1000 A	101776	Ex9MD1B TM DC100 3P	1/8
125 A	100—125 A	1250 A	101777	Ex9MD1B TM DC125 3P	1/8
16 A	12.8—16 A	160 A	101828	Ex9MD1B TM DC16 4P4T	1/8
20 A	16—20 A	200 A	101829	Ex9MD1B TM DC20 4P4T	1/8
25 A	20—25 A	250 A	101830	Ex9MD1B TM DC25 4P4T	1/8
32 A	25.6—32 A	320 A	101831	Ex9MD1B TM DC32 4P4T	1/8
40 A	32—40 A	400 A	101832	Ex9MD1B TM DC40 4P4T	1/8
50 A	40—50 A	500 A	101833	Ex9MD1B TM DC50 4P4T	1/8
63 A	50.4—63 A	630 A	101834	Ex9MD1B TM DC63 4P4T	1/8
80 A	64—80 A	800 A	101835	Ex9MD1B TM DC80 4P4T	1/8
100 A	80—100 A	1000 A	101836	Ex9MD1B TM DC100 4P4T	1/8
125 A	100—125 A	1250 A	101837	Ex9MD1B TM DC125 4P4T	1/8

## Version Ex9MD1S, $I_{cu} = 36 \text{ kA}$

- DC Moulded Case Circuit Breakers
- 3 and 4-pole versions
- $I_{cs} = I_{cu} = 36 \text{ kA}$  at 750/1000 V DC
- $I_r$  can be set in steps  $(0.8-0.9-1.0) \times I_n$
- $I_i$  fixed as  $10 \times I_n$
- Mounting screws, interconnection busbars as well as phase barriers in the scope of delivery



Rated current $I_n$	Overcurrent release $I_r$	Instant. release $I_i$	Article No.	Type	Packing
16 A	12.8—16 A	160 A	101778	Ex9MD1S TM DC16 3P	1/8
20 A	16—20 A	200 A	101779	Ex9MD1S TM DC20 3P	1/8
25 A	20—25 A	250 A	101780	Ex9MD1S TM DC25 3P	1/8
32 A	25.6—32 A	320 A	101781	Ex9MD1S TM DC32 3P	1/8
40 A	32—40 A	400 A	101782	Ex9MD1S TM DC40 3P	1/8
50 A	40—50 A	500 A	101783	Ex9MD1S TM DC50 3P	1/8
63 A	50.4—63 A	630 A	101784	Ex9MD1S TM DC63 3P	1/8
80 A	64—80 A	800 A	101785	Ex9MD1S TM DC80 3P	1/8
100 A	80—100 A	1000 A	101786	Ex9MD1S TM DC100 3P	1/8
125 A	100—125 A	1250 A	101787	Ex9MD1S TM DC125 3P	1/8
16 A	12.8—16 A	160 A	101838	Ex9MD1S TM DC16 4P4T	1/8
20 A	16—20 A	200 A	101839	Ex9MD1S TM DC20 4P4T	1/8
25 A	20—25 A	250 A	101840	Ex9MD1S TM DC25 4P4T	1/8
32 A	25.6—32 A	320 A	101841	Ex9MD1S TM DC32 4P4T	1/8
40 A	32—40 A	400 A	101842	Ex9MD1S TM DC40 4P4T	1/8
50 A	40—50 A	500 A	101843	Ex9MD1S TM DC50 4P4T	1/8
63 A	50.4—63 A	630 A	101844	Ex9MD1S TM DC63 4P4T	1/8
80 A	64—80 A	800 A	101845	Ex9MD1S TM DC80 4P4T	1/8
100 A	80—100 A	1000 A	101846	Ex9MD1S TM DC100 4P4T	1/8
125 A	100—125 A	1250 A	101847	Ex9MD1S TM DC125 4P4T	1/8

Technical data p. 118

# DC MCCBs Ex9MD1 up to 125 A

## Version Ex9MD1N, $I_{cu} = 50 \text{ kA}$

- DC Moulded Case Circuit Breakers
- 3 and 4-pole versions
- $I_{cs} = I_{cu} = 50 \text{ kA}$  at 750/1000 V DC
- $I_r$  can be set in steps  $(0.8-0.9-1.0) \times I_n$
- $I_i$  fixed as  $10 \times I_n$
- Mounting screws, interconnection busbars as well as phase barriers in the scope of delivery



Rated current $I_n$	Overcurrent release $I_r$	Instant. release $I_i$	Article No.	Type	Packing
16 A	12.8—16 A	160 A	101788	Ex9MD1N TM DC16 3P	1/8
20 A	16—20 A	200 A	101789	Ex9MD1N TM DC20 3P	1/8
25 A	20—25 A	250 A	101790	Ex9MD1N TM DC25 3P	1/8
32 A	25.6—32 A	320 A	101791	Ex9MD1N TM DC32 3P	1/8
40 A	32—40 A	400 A	101792	Ex9MD1N TM DC40 3P	1/8
50 A	40—50 A	500 A	101793	Ex9MD1N TM DC50 3P	1/8
63 A	50.4—63 A	630 A	101794	Ex9MD1N TM DC63 3P	1/8
80 A	64—80 A	800 A	101795	Ex9MD1N TM DC80 3P	1/8
100 A	80—100 A	1000 A	101796	Ex9MD1N TM DC100 3P	1/8
125 A	100—125 A	1250 A	101797	Ex9MD1N TM DC125 3P	1/8
16 A	12.8—16 A	160 A	101848	Ex9MD1N TM DC16 4P4T	1/8
20 A	16—20 A	200 A	101849	Ex9MD1N TM DC20 4P4T	1/8
25 A	20—25 A	250 A	101850	Ex9MD1N TM DC25 4P4T	1/8
32 A	25.6—32 A	320 A	101851	Ex9MD1N TM DC32 4P4T	1/8
40 A	32—40 A	400 A	101852	Ex9MD1N TM DC40 4P4T	1/8
50 A	40—50 A	500 A	101853	Ex9MD1N TM DC50 4P4T	1/8
63 A	50.4—63 A	630 A	101854	Ex9MD1N TM DC63 4P4T	1/8
80 A	64—80 A	800 A	101855	Ex9MD1N TM DC80 4P4T	1/8
100 A	80—100 A	1000 A	101856	Ex9MD1N TM DC100 4P4T	1/8
125 A	100—125 A	1250 A	101857	Ex9MD1N TM DC125 4P4T	1/8

## Version Ex9MD1H, $I_{cu} = 100 \text{ kA}$

- DC Moulded Case Circuit Breakers
- 3 and 4-pole versions
- $I_{cs} = I_{cu} = 100 \text{ kA}$  at 750/1000 V DC
- $I_r$  can be set in steps  $(0.8-0.9-1.0) \times I_n$
- $I_i$  fixed as  $10 \times I_n$
- Mounting screws, interconnection busbars as well as phase barriers in the scope of delivery



Rated current $I_n$	Overcurrent release $I_r$	Instant. release $I_i$	Article No.	Type	Packing
16 A	12.8—16 A	160 A	101818	Ex9MD1H TM DC16 3P	1/8
20 A	16—20 A	200 A	101819	Ex9MD1H TM DC20 3P	1/8
25 A	20—25 A	250 A	101820	Ex9MD1H TM DC25 3P	1/8
32 A	25.6—32 A	320 A	101821	Ex9MD1H TM DC32 3P	1/8
40 A	32—40 A	400 A	101822	Ex9MD1H TM DC40 3P	1/8
50 A	40—50 A	500 A	101823	Ex9MD1H TM DC50 3P	1/8
63 A	50.4—63 A	630 A	101824	Ex9MD1H TM DC63 3P	1/8
80 A	64—80 A	800 A	101825	Ex9MD1H TM DC80 3P	1/8
100 A	80—100 A	1000 A	101826	Ex9MD1H TM DC100 3P	1/8
125 A	100—125 A	1250 A	101827	Ex9MD1H TM DC125 3P	1/8
16 A	12.8—16 A	160 A	101878	Ex9MD1H TM DC16 4P4T	1/8
20 A	16—20 A	200 A	101879	Ex9MD1H TM DC20 4P4T	1/8
25 A	20—25 A	250 A	101880	Ex9MD1H TM DC25 4P4T	1/8
32 A	25.6—32 A	320 A	101881	Ex9MD1H TM DC32 4P4T	1/8
40 A	32—40 A	400 A	101882	Ex9MD1H TM DC40 4P4T	1/8
50 A	40—50 A	500 A	101883	Ex9MD1H TM DC50 4P4T	1/8
63 A	50.4—63 A	630 A	101884	Ex9MD1H TM DC63 4P4T	1/8
80 A	64—80 A	800 A	101885	Ex9MD1H TM DC80 4P4T	1/8
100 A	80—100 A	1000 A	101886	Ex9MD1H TM DC100 4P4T	1/8
125 A	100—125 A	1250 A	101887	Ex9MD1H TM DC125 4P4T	1/8

# DC MCCBs Ex9MD2 up to 250 A

## Version Ex9MD2B, $I_{cu} = 25$ kA

- DC Moulded Case Circuit Breakers
- 3 and 4-pole versions
- $I_{cs} = I_{cu} = 25$  kA at 750/1000 V DC
- $I_r$  can be set in steps  $(0.8-0.9-1.0) \times I_n$
- $I_r$  variable  $(5-6-7-8-9-10) \times I_n$
- Mounting screws, interconnection busbars as well as phase barriers in the scope of delivery



Rated current $I_n$	Overcurrent release $I_r$	Instant. release $I_i$	Article No.	Type	Packing
125 A	100-125 A	625-1250	101888	Ex9MD2B TM DC125 3P	1/4
160 A	128-160 A	800-1600	101889	Ex9MD2B TM DC160 3P	1/4
180 A	144-180 A	900-1800	101890	Ex9MD2B TM DC180 3P	1/4
200 A	160-200 A	1000-2000	101891	Ex9MD2B TM DC200 3P	1/4
225 A	180-225 A	1125-2250	101892	Ex9MD2B TM DC225 3P	1/4
250 A	200-250 A	1250-2500	101893	Ex9MD2B TM DC250 3P	1/4
125 A	100-125 A	625-1250	101924	Ex9MD2B TM DC125 4P4T	1/4
160 A	128-160 A	800-1600	101925	Ex9MD2B TM DC160 4P4T	1/4
180 A	144-180 A	900-1800	101926	Ex9MD2B TM DC180 4P4T	1/4
200 A	160-200 A	1000-2000	101927	Ex9MD2B TM DC200 4P4T	1/4
225 A	180-225 A	1125-2250	101928	Ex9MD2B TM DC225 4P4T	1/4
250 A	200-250 A	1250-2500	101929	Ex9MD2B TM DC250 4P4T	1/4

## Version Ex9MD2S, $I_{cu} = 36$ kA

- DC Moulded Case Circuit Breakers
- 3 and 4-pole versions
- $I_{cs} = I_{cu} = 36$  kA at 750/1000 V DC
- $I_r$  can be set in steps  $(0.8-0.9-1.0) \times I_n$
- $I_r$  variable  $(5-6-7-8-9-10) \times I_n$
- Mounting screws, interconnection busbars as well as phase barriers in the scope of delivery



Rated current $I_n$	Overcurrent release $I_r$	Instant. release $I_i$	Article No.	Type	Packing
125 A	100-125 A	625-1250	101894	Ex9MD2S TM DC125 3P	1/4
160 A	128-160 A	800-1600	101895	Ex9MD2S TM DC160 3P	1/4
180 A	144-180 A	900-1800	101896	Ex9MD2S TM DC180 3P	1/4
200 A	160-200 A	1000-2000	101897	Ex9MD2S TM DC200 3P	1/4
225 A	180-225 A	1125-2250	101898	Ex9MD2S TM DC225 3P	1/4
250 A	200-250 A	1250-2500	101899	Ex9MD2S TM DC250 3P	1/4
125 A	100-125 A	625-1250	101930	Ex9MD2S TM DC125 4P4T	1/4
160 A	128-160 A	800-1600	101931	Ex9MD2S TM DC160 4P4T	1/4
180 A	144-180 A	900-1800	101932	Ex9MD2S TM DC180 4P4T	1/4
200 A	160-200 A	1000-2000	101933	Ex9MD2S TM DC200 4P4T	1/4
225 A	180-225 A	1125-2250	101934	Ex9MD2S TM DC225 4P4T	1/4
250 A	200-250 A	1250-2500	101935	Ex9MD2S TM DC250 4P4T	1/4



# DC MCCBs Ex9MD2 up to 250 A

## Version Ex9MD2N, $I_{cu} = 50 \text{ kA}$

- DC Moulded Case Circuit Breakers
- 3 and 4-pole versions
- $I_{cs} = I_{cu} = 50 \text{ kA}$  at 750/1000 V DC
- $I_r$  can be set in steps  $(0.8-0.9-1.0) \times I_n$
- $I_i$  variable  $(5-6-7-8-9-10) \times I_n$
- Mounting screws, interconnection busbars as well as phase barriers in the scope of delivery



Rated current $I_n$	Overcurrent release $I_r$	Instant. release $I_i$	Article No.	Type	Packing
125 A	100-125 A	625-1250	101900	Ex9MD2N TM DC125 3P	1/4
160 A	128-160 A	800-1600	101901	Ex9MD2N TM DC160 3P	1/4
180 A	144-180 A	900-1800	101902	Ex9MD2N TM DC180 3P	1/4
200 A	160-200 A	1000-2000	101903	Ex9MD2N TM DC200 3P	1/4
225 A	180-225 A	1125-2250	101904	Ex9MD2N TM DC225 3P	1/4
250 A	200-250 A	1250-2500	101905	Ex9MD2N TM DC250 3P	1/4
125 A	100-125 A	625-1250	101936	Ex9MD2N TM DC125 4P4T	1/4
160 A	128-160 A	800-1600	101937	Ex9MD2N TM DC160 4P4T	1/4
180 A	144-180 A	900-1800	101938	Ex9MD2N TM DC180 4P4T	1/4
200 A	160-200 A	1000-2000	101939	Ex9MD2N TM DC200 4P4T	1/4
225 A	180-225 A	1125-2250	101940	Ex9MD2N TM DC225 4P4T	1/4
250 A	200-250 A	1250-2500	101941	Ex9MD2N TM DC250 4P4T	1/4

## Version Ex9MD2H, $I_{cu} = 100 \text{ kA}$

- DC Moulded Case Circuit Breakers
- 3 and 4-pole versions
- $I_{cs} = I_{cu} = 100 \text{ kA}$  at 750/1000 V DC
- $I_r$  can be set in steps  $(0.8-0.9-1.0) \times I_n$
- $I_i$  variable  $(5-6-7-8-9-10) \times I_n$
- Mounting screws, interconnection busbars as well as phase barriers in the scope of delivery



Rated current $I_n$	Overcurrent release $I_r$	Instant. release $I_i$	Article No.	Type	Packing
125 A	100-125 A	625-1250	101918	Ex9MD2H TM DC125 3P	1/4
160 A	128-160 A	800-1600	101919	Ex9MD2H TM DC160 3P	1/4
180 A	144-180 A	900-1800	101920	Ex9MD2H TM DC180 3P	1/4
200 A	160-200 A	1000-2000	101921	Ex9MD2H TM DC200 3P	1/4
225 A	180-225 A	1125-2250	101922	Ex9MD2H TM DC225 3P	1/4
250 A	200-250 A	1250-2500	101923	Ex9MD2H TM DC250 3P	1/4
125 A	100-125 A	625-1250	101954	Ex9MD2H TM DC125 4P4T	1/4
160 A	128-160 A	800-1600	101955	Ex9MD2H TM DC160 4P4T	1/4
180 A	144-180 A	900-1800	101956	Ex9MD2H TM DC180 4P4T	1/4
200 A	160-200 A	1000-2000	101957	Ex9MD2H TM DC200 4P4T	1/4
225 A	180-225 A	1125-2250	101958	Ex9MD2H TM DC225 4P4T	1/4
250 A	200-250 A	1250-2500	101959	Ex9MD2H TM DC250 4P4T	1/4

# DC MCCBs Ex9MD3 up to 400 A

## Version Ex9MD3B, $I_{cu} = 25$ kA

- DC Moulded Case Circuit Breakers
- 3 and 4-pole versions
- $I_{cs} = I_{cu} = 25$  kA at 750/1000 V DC
- $I_r$  can be set in steps  $(0.8-0.9-1.0) \times I_n$
- $I_i$  variable  $(5-6-7-8-9-10) \times I_n$
- Mounting screws, interconnection busbars as well as phase barriers in the scope of delivery



Rated current $I_n$	Overcurrent release $I_r$	Instant. release $I_i$	Article No.	Type	Packing
250 A	200-250 A	1250-2500	101960	Ex9MD3B TM DC250 3P	1/2
315 A	252-315 A	1575-3150	101961	Ex9MD3B TM DC315 3P	1/2
350 A	280-350 A	1750-3500	101962	Ex9MD3B TM DC350 3P	1/2
400 A	320-400 A	2000-4000	101963	Ex9MD3B TM DC400 3P	1/2
250 A	200-250 A	1250-2500	101984	Ex9MD3B TM DC250 4P4T	1/2
315 A	252-315 A	1575-3150	101985	Ex9MD3B TM DC315 4P4T	1/2
350 A	280-350 A	1750-3500	101986	Ex9MD3B TM DC350 4P4T	1/2
400 A	320-400 A	2000-4000	101987	Ex9MD3B TM DC400 4P4T	1/2

## Version Ex9MD3S, $I_{cu} = 36$ kA

- DC Moulded Case Circuit Breakers
- 3 and 4-pole versions
- $I_{cs} = I_{cu} = 36$  kA at 750/1000 V AC
- $I_r$  can be set in steps  $(0.8-0.9-1.0) \times I_n$
- $I_i$  variable  $(5-6-7-8-9-10) \times I_n$
- Mounting screws, interconnection busbars as well as phase barriers in the scope of delivery



Rated current $I_n$	Overcurrent release $I_r$	Instant. release $I_i$	Article No.	Type	Packing
250 A	200-250 A	1250-2500	101964	Ex9MD3S TM DC250 3P	1/2
315 A	252-315 A	1575-3150	101965	Ex9MD3S TM DC315 3P	1/2
350 A	280-350 A	1750-3500	101966	Ex9MD3S TM DC350 3P	1/2
400 A	320-400 A	2000-4000	101967	Ex9MD3S TM DC400 3P	1/2
250 A	200-250 A	1250-2500	101988	Ex9MD3S TM DC250 4P4T	1/2
315 A	252-315 A	1575-3150	101989	Ex9MD3S TM DC315 4P4T	1/2
350 A	280-350 A	1750-3500	101990	Ex9MD3S TM DC350 4P4T	1/2
400 A	320-400 A	2000-4000	101991	Ex9MD3S TM DC400 4P4T	1/2

# DC MCCBs Ex9MD3 up to 400 A

## Version Ex9MD3N, $I_{cu} = 50$ kA

- DC Moulded Case Circuit Breakers
- 3 and 4-pole versions
- $I_{cs} = I_{cu} = 50$  kA at 750/1000 V DC
- $I_r$  can be set in steps  $(0.8-0.9-1.0) \times I_n$
- $I_j$  variable  $(5-6-7-8-9-10) \times I_n$
- Mounting screws, interconnection busbars as well as phase barriers in the scope of delivery



Rated current $I_n$	Overcurrent release $I_r$	Instant. release $I_j$	Article No.	Type	Packing
250 A	200-250 A	1250-2500	101968	Ex9MD3N TM DC250 3P	1/2
315 A	252-315 A	1575-3150	101969	Ex9MD3N TM DC315 3P	1/2
350 A	280-350 A	1750-3500	101970	Ex9MD3N TM DC350 3P	1/2
400 A	320-400 A	2000-4000	101971	Ex9MD3N TM DC400 3P	1/2
250 A	200-250 A	1250-2500	101992	Ex9MD3N TM DC250 4P4T	1/2
315 A	252-315 A	1575-3150	101993	Ex9MD3N TM DC315 4P4T	1/2
350 A	280-350 A	1750-3500	101994	Ex9MD3N TM DC350 4P4T	1/2
400 A	320-400 A	2000-4000	101995	Ex9MD3N TM DC400 4P4T	1/2

## Version Ex9MD3H, $I_{cu} = 100$ kA

- DC Moulded Case Circuit Breakers
- 3 and 4-pole versions
- $I_{cs} = I_{cu} = 100$  kA at 750/1000 V DC
- $I_r$  can be set in steps  $(0.8-0.9-1.0) \times I_n$
- $I_j$  variable  $(5-6-7-8-9-10) \times I_n$
- Mounting screws, interconnection busbars as well as phase barriers in the scope of delivery



Rated current $I_n$	Overcurrent release $I_r$	Instant. release $I_j$	Article No.	Type	Packing
250 A	200-250 A	1250-2500	101980	Ex9MD3H TM DC250 3P	1/2
315 A	252-315 A	1575-3150	101981	Ex9MD3H TM DC315 3P	1/2
350 A	280-350 A	1750-3500	101982	Ex9MD3H TM DC350 3P	1/2
400 A	320-400 A	2000-4000	101983	Ex9MD3H TM DC400 3P	1/2
250 A	200-250 A	1250-2500	101204	Ex9MD3H TM DC250 4P4T	1/2
315 A	252-315 A	1575-3150	101205	Ex9MD3H TM DC315 4P4T	1/2
350 A	280-350 A	1750-3500	101206	Ex9MD3H TM DC350 4P4T	1/2
400 A	320-400 A	2000-4000	101207	Ex9MD3H TM DC400 4P4T	1/2

# DC MCCBs Ex9MD4 up to 630 A

## Version Ex9MD4B, $I_{cu} = 25 \text{ kA}$

- DC Moulded Case Circuit Breakers
- 3 and 4-pole versions
- $I_{cs} = I_{cu} = 25 \text{ kA}$  at 750/1000 V DC
- $I_r$  can be set in steps  $(0.8-0.9-1.0) \times I_n$
- $I_r$  variable  $(5-6-7-8-9-10) \times I_n$
- Mounting screws, interconnection busbars as well as phase barriers in the scope of delivery



Rated current $I_n$	Overcurrent release $I_r$	Instant. release $I_i$	Article No.	Type	Packing
400 A	320-400 A	2000-4000	103932	Ex9MD4B TM DC400 3P	1/2
500 A	400-500 A	2500-5000	103933	Ex9MD4B TM DC500 3P	1/2
630 A	504-630 A	3150-6300	103934	Ex9MD4B TM DC630 3P	1/2
400 A	320-400 A	2000-4000	103950	Ex9MD4B TM DC400 4P4T	1/2
500 A	400-500 A	2500-5000	103951	Ex9MD4B TM DC500 4P4T	1/2
630 A	504-630 A	3150-6300	103952	Ex9MD4B TM DC630 4P4T	1/2

## Version Ex9MD4S, $I_{cu} = 36 \text{ kA}$

- DC Moulded Case Circuit Breakers
- 3 and 4-pole versions
- $I_{cs} = I_{cu} = 36 \text{ kA}$  at 750/1000 V AC
- $I_r$  can be set in steps  $(0.8-0.9-1.0) \times I_n$
- $I_r$  variable  $(5-6-7-8-9-10) \times I_n$
- Mounting screws, interconnection busbars as well as phase barriers in the scope of delivery



Rated current $I_n$	Overcurrent release $I_r$	Instant. release $I_i$	Article No.	Type	Packing
400 A	320-400 A	2000-4000	103935	Ex9MD4S TM DC400 3P	1/2
500 A	400-500 A	2500-5000	103936	Ex9MD4S TM DC500 3P	1/2
630 A	504-630 A	3150-6300	103937	Ex9MD4S TM DC630 3P	1/2
400 A	320-400 A	2000-4000	103953	Ex9MD4S TM DC400 4P4T	1/2
500 A	400-500 A	2500-5000	103954	Ex9MD4S TM DC500 4P4T	1/2
630 A	504-630 A	3150-6300	103955	Ex9MD4S TM DC630 4P4T	1/2

# DC MCCBs Ex9MD4 up to 630 A

## Version Ex9MD4N, $I_{cu} = 50 \text{ kA}$

- DC Moulded Case Circuit Breakers
- 3 and 4-pole versions
- $I_{cs} = I_{cu} = 50 \text{ kA}$  at 750/1000 V DC
- $I_r$  can be set in steps  $(0.8-0.9-1.0) \times I_n$
- $I_j$  variable  $(5-6-7-8-9-10) \times I_n$
- Mounting screws, interconnection busbars as well as phase barriers in the scope of delivery



Rated current $I_n$	Overcurrent release $I_r$	Instant. release $I_j$	Article No.	Type	Packing
400 A	320-400 A	2000-4000	103938	Ex9MD4N TM DC400 3P	1/2
500 A	400-500 A	2500-5000	103939	Ex9MD4N TM DC500 3P	1/2
630 A	504-630 A	3150-6300	103940	Ex9MD4N TM DC630 3P	1/2
400 A	320-400 A	2000-4000	103956	Ex9MD4N TM DC400 4P4T	1/2
500 A	400-500 A	2500-5000	103957	Ex9MD4N TM DC500 4P4T	1/2
630 A	504-630 A	3150-6300	103958	Ex9MD4N TM DC630 4P4T	1/2

## Version Ex9MD4H, $I_{cu} = 100 \text{ kA}$

- DC Moulded Case Circuit Breakers
- 3 and 4-pole versions
- $I_{cs} = I_{cu} = 100 \text{ kA}$  at 750/1000 V DC
- $I_r$  can be set in steps  $(0.8-0.9-1.0) \times I_n$
- $I_j$  variable  $(5-6-7-8-9-10) \times I_n$
- Mounting screws, interconnection busbars as well as phase barriers in the scope of delivery



Rated current $I_n$	Overcurrent release $I_r$	Instant. release $I_j$	Article No.	Type	Packing
400 A	320-400 A	2000-4000	103947	Ex9MD4H TM DC400 3P	1/2
500 A	400-500 A	2500-5000	103948	Ex9MD4H TM DC500 3P	1/2
630 A	504-630 A	3150-6300	103949	Ex9MD4H TM DC630 3P	1/2
400 A	320-400 A	2000-4000	103965	Ex9MD4H TM DC400 4P4T	1/2
500 A	400-500 A	2500-5000	103966	Ex9MD4H TM DC500 4P4T	1/2
630 A	504-630 A	3150-6300	103967	Ex9MD4H TM DC630 4P4T	1/2

# DC MCCBs Ex9MD5 up to 800 A

## Version Ex9MD5B, $I_{cu} = 25$ kA

- DC Moulded Case Circuit Breakers
- 3 and 4-pole versions
- $I_{cs} = I_{cu} = 25$  kA at 750/1000 V DC
- $I_r$  can be set in steps  $(0.8-0.9-1.0) \times I_n$
- $I_f$  variable  $(5-6-7-8-9-10) \times I_n$
- Mounting screws, interconnection busbars as well as phase barriers in the scope of delivery



Rated current $I_n$	Overcurrent release $I_r$	Instant. release $I_f$	Article No.	Type	Packing
630 A	504-630 A	3150-6300	103968	Ex9MD5B TM DC630 3P	1/2
700 A	560-700 A	3500-7000	103969	Ex9MD5B TM DC700 3P	1/2
800 A	640-800 A	4000-8000	103970	Ex9MD5B TM DC800 3P	1/2
630 A	504-630 A	3150-6300	103986	Ex9MD5B TM DC630 4P4T	1/2
700 A	560-700 A	3500-7000	103987	Ex9MD5B TM DC700 4P4T	1/2
800 A	640-800 A	4000-8000	103988	Ex9MD5B TM DC800 4P4T	1/2

## Version Ex9MD5S, $I_{cu} = 36$ kA

- DC Moulded Case Circuit Breakers
- 3 and 4-pole versions
- $I_{cs} = I_{cu} = 36$  kA at 750/1000 V AC
- $I_r$  can be set in steps  $(0.8-0.9-1.0) \times I_n$
- $I_f$  variable  $(5-6-7-8-9-10) \times I_n$
- Mounting screws, interconnection busbars as well as phase barriers in the scope of delivery



Rated current $I_n$	Overcurrent release $I_r$	Instant. release $I_f$	Article No.	Type	Packing
630 A	504-630 A	3150-6300	103971	Ex9MD5S TM DC630 3P	1/2
700 A	560-700 A	3500-7000	103972	Ex9MD5S TM DC700 3P	1/2
800 A	640-800 A	4000-8000	103973	Ex9MD5S TM DC800 3P	1/2
630 A	504-630 A	3150-6300	103989	Ex9MD5S TM DC630 4P4T	1/2
700 A	560-700 A	3500-7000	103990	Ex9MD5S TM DC700 4P4T	1/2
800 A	640-800 A	4000-8000	103991	Ex9MD5S TM DC800 4P4T	1/2

# DC MCCBs Ex9MD5 up to 800 A

## Version Ex9MD5N, $I_{cu} = 50$ kA

- DC Moulded Case Circuit Breakers
- 3 and 4-pole versions
- $I_{cs} = I_{cu} = 50$  kA at 750/1000 V DC
- $I_r$  can be set in steps  $(0.8-0.9-1.0) \times I_n$
- $I_j$  variable  $(5-6-7-8-9-10) \times I_n$
- Mounting screws, interconnection busbars as well as phase barriers in the scope of delivery



Rated current $I_n$	Overcurrent release $I_r$	Instant. release $I_j$	Article No.	Type	Packing
630 A	504-630 A	3150-6300	103974	Ex9MD5N TM DC630 3P	1/2
700 A	560-700 A	3500-7000	103975	Ex9MD5N TM DC700 3P	1/2
800 A	640-800 A	4000-8000	103976	Ex9MD5N TM DC800 3P	1/2
630 A	504-630 A	3150-6300	103992	Ex9MD5N TM DC630 4P4T	1/2
700 A	560-700 A	3500-7000	103993	Ex9MD5N TM DC700 4P4T	1/2
800 A	640-800 A	4000-8000	103994	Ex9MD5N TM DC800 4P4T	1/2

## Version Ex9MD5H, $I_{cu} = 100$ kA

- DC Moulded Case Circuit Breakers
- 3 and 4-pole versions
- $I_{cs} = I_{cu} = 100$  kA at 750/1000 V DC
- $I_r$  can be set in steps  $(0.8-0.9-1.0) \times I_n$
- $I_j$  variable  $(5-6-7-8-9-10) \times I_n$
- Mounting screws, interconnection busbars as well as phase barriers in the scope of delivery



Rated current $I_n$	Overcurrent release $I_r$	Instant. release $I_j$	Article No.	Type	Packing
630 A	504-630 A	3150-6300	103983	Ex9MD5H TM DC630 3P	1/2
700 A	560-700 A	3500-7000	103984	Ex9MD5H TM DC700 3P	1/2
800 A	640-800 A	4000-8000	103985	Ex9MD5H TM DC800 3P	1/2
630 A	504-630 A	3150-6300	104001	Ex9MD5H TM DC630 4P4T	1/2
700 A	560-700 A	3500-7000	104002	Ex9MD5H TM DC700 4P4T	1/2
800 A	640-800 A	4000-8000	104003	Ex9MD5H TM DC800 4P4T	1/2

# Notes

A large grid of dashed lines for taking notes, consisting of 20 columns and 30 rows.



# DC MCCBs Ex9MV2S-PV



- DC Moulded Case Circuit Breakers suitable for photovoltaic applications
- Frame size M2
- Rated current up to 250 A
- Rated ultimate short circuit breaking capacity  $I_{cu} = 15 \text{ kA}$ ,  $I_{cs} = 100 \% I_{cu}$
- Rated voltage 1500 V DC
- Thermomagnetic releases
- Fixed version

DC Moulded Case Circuit Breakers Ex9MV2S-PV are intended mainly for photovoltaic applications. Testing according to IEC / EN 60947-2 standards ensures functions and reliability for wide variety of applications including isolation.

These breakers are offered with breaking capacity of 15 kA. Rated impulse withstand voltage  $U_{imp} 12 \text{ kV}$  makes it possible to use them even in systems with occurrences of transient overvoltage waves of high intensity.

Utilization category A.

## Type Key

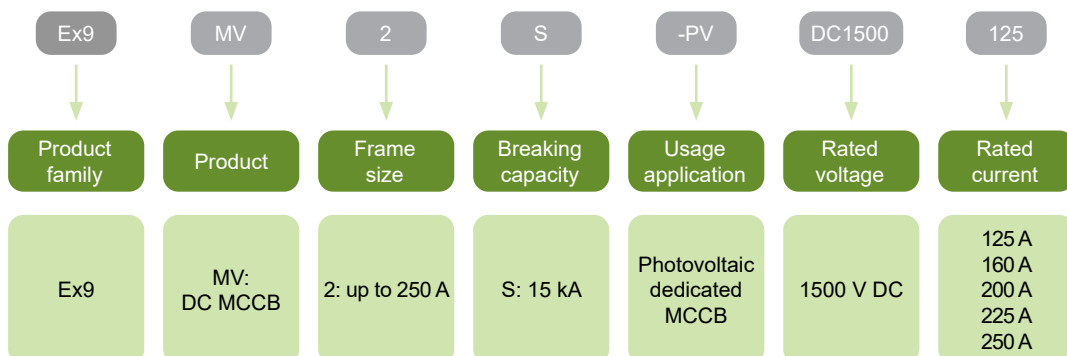

## Certification marks



# DC MCCBs Ex9MV2S-PV

## Version Ex9MV2S-PV/DC1500, $I_{cu} = 15 \text{ kA}$

- DC Moulded Case Circuit Breakers suitable for photovoltaic
- $I_{cs} = I_{cu} = 15 \text{ kA}$  at 1500 V DC
- Fixed version
- Instantaneous release  $I_i = I_n \times 10$
- Mounting screws and phase barriers in the scope of delivery



Rated current $I_n$	Article No.	Type	Packing
125 A	110194	Ex9MV2S-PV/DC1500 125	1/8
160 A	110195	Ex9MV2S-PV/DC1500 160	1/8
200 A	110196	Ex9MV2S-PV/DC1500 200	1/8
225 A	110197	Ex9MV2S-PV/DC1500 225	1/8
250 A	110198	Ex9MV2S-PV/DC1500 250	1/8

# DC MCCB Switch Disconnectors Ex9MSD



- DC MCCB Switch Disconnectors
- Frame sizes M1- M5
- Rated current up to 800 A
- Tested according to EN 60947-3
- DC current character
- Rated operating voltage  $U_e$  up to 1000 V DC (4-pole DC version)
- Fixed version

DC MCCB based Switch Disconnectors Ex9MSD are used as a main switch in all kinds of DC applications. Thanks to its polarity independence can be used also for PV. They serve there as a main disconnector of DC side of the power plant.

These switch disconnectors have same size and design as standard Ex9M MCCBs. Therefore there is the possibility to use fully compatible range of external and internal accessories including extended rotary handles, auxiliary contacts, tripping units, motor operators and terminal covers.

## Type Key

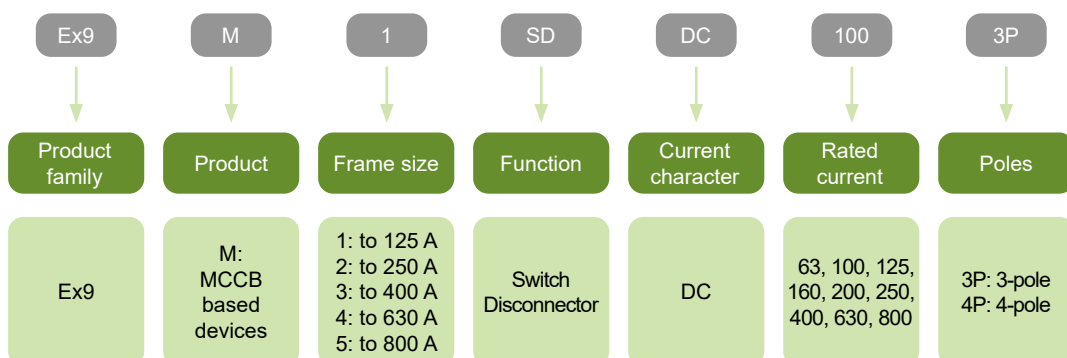

## Certification marks



# DC MCCB Switch Disconnectors Ex9MSD

## Internal accessories

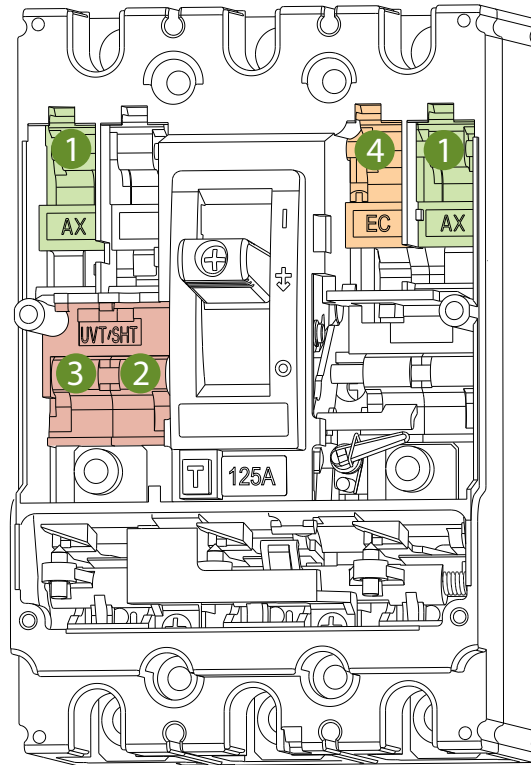

1

Auxiliary contact  
**AX21**

2

Shunt trip release  
**SHT2i**  
1 unit or UVT2i

3

Undervoltage release  
**UVT2i**  
1 unit or SHT2i

4

Early-make  
auxiliary contact  
**EC2i**

Auxiliary contact AX21

see page 62

Shunt trip releases SHT2i

see page 62

Undervoltage releases UVT2i

see page 63

Early-make auxiliary contact EC2i

see page 62

All internal accessories for the frame sizes M2+M3 and M4+M5 are identical.

The undervoltage release UVT in PV system is intended e.g. for safe remote disconnection of DC part from installation.

# DC MCCB Switch Disconnectors Ex9MSD

## External accessories



Phase barriers  
**PB2i**



Terminal cover, short  
**TCV2i**



Terminal cover, long  
**TCE2i**



Box terminals  
**MC2i**



Tunnel terminals  
**MC2i W**



Mounting depth spacers  
**WG i**



Remote operator  
**MOD2i**



Direct rotary handle  
**RHD2i**



Extended rotary handle  
**ERH2i**

Phase barriers PB2i

Terminal cover, short TCV2i

Terminal cover, long TCE2i

Remote operators MOD2i

Direct rotary handles RHD2i

Extended rotary handles ERH2i

Connection terminals MC2i

Mounting depth spacers WG i

see page 64

see page 65

see page 66

see page 63

see page 64

see page 64

see page 65

see page 66

# DC MCCB Switch Disconnectors Ex9MSD

## 750 V DC versions

- Mounting screws, interconnection busbars as well as phase barriers in the scope of delivery
- The operating voltage 750 V DC is reach via serial connection of three contacts by means of interconnection busbars



Rated current $I_n$	Frame size	Article No.	Type	Packing
63 A	M1	102008	Ex9M1SD DC63 3P	1/8
100 A	M1	102009	Ex9M1SD DC100 3P	1/8
125 A	M1	102010	Ex9M1SD DC125 3P	1/8
125 A	M2	102014	Ex9M2SD DC125 3P	1/4
160 A	M2	102015	Ex9M2SD DC160 3P	1/4
200 A	M2	102016	Ex9M2SD DC200 3P	1/4
250 A	M2	102017	Ex9M2SD DC250 3P	1/4
250 A	M3	102022	Ex9M3SD DC250 3P	1/2
400 A	M3	102023	Ex9M3SD DC400 3P	1/2
630 A	M4	104008	Ex9M4SD DC630 3P	1
800 A	M5	104010	Ex9M5SD DC800 3P	1

## 1000 V DC versions

- Mounting screws, interconnection busbars as well as phase barriers in the scope of delivery
- The operating voltage 1000 V DC is reach via serial connection of four contacts by means of interconnection busbars



Rated current $I_n$	Frame size	Article No.	Type	Packing
63 A	M1	102011	Ex9M1SD DC63 4P	1/8
100 A	M1	102012	Ex9M1SD DC100 4P	1/8
125 A	M1	102013	Ex9M1SD DC125 4P	1/8
125 A	M2	102018	Ex9M2SD DC125 4P	1/4
160 A	M2	102019	Ex9M2SD DC160 4P	1/4
200 A	M2	102020	Ex9M2SD DC200 4P	1/4
250 A	M2	102021	Ex9M2SD DC250 4P	1/4
250 A	M3	102024	Ex9M3SD DC250 4P	1/2
400 A	M3	102025	Ex9M3SD DC400 4P	1/2
630 A	M4	104009	Ex9M4SD DC630 4P	1
800 A	M5	104011	Ex9M5SD DC800 4P	1

# Accessories for MCCBs Ex9M



- Accessories for Ex9M line devices
- Auxiliary contacts synchronous with main contacts
- Signal contacts active on electrical tripping of the circuit breaker (tripping signal contacts)
- Shunt trip and undervoltage releases
- Remote operators
- Rotary handles
- Connection terminals and covers
- Mounting depth spacers and adaptors

Accessories suitable for Moulded Case Circuit Breakers Ex9M. It is possible to supplement or modify functions of a basic circuit breaker by installing of suitable accessories.

Circuit breakers can be equipped with auxiliary contacts AX21 (up to 2 units even for M1 frame size) and one unit of signal contact AL21 or early make auxiliary contact EC 2*i*. AX21 and AL21/EC 2*i* are mounted into different positions, a use of one type of the contact does not limit a number of the second type. AX21 and AL21/EC 2*i* can be used regardless the frame size of the circuit breaker.

One unit of undervoltage release UVT2*i* or one unit of shunt trip relase SHT2*i* can be installed in the breaker. Different versions for different frame sizes allow to optimise power consumption of these units.

The circuit breakers can also be equipped with different accesories for operation of the toggle. There are available direct rotary handle, rotary handle with extended shaft e.g. for door coupling and a motor operator.

Mounting of the device onto plate can be done directly with the screws which are included in the scope of delivery. Or in case of M1 and M2 devices there is possibility to use adaptors DRA for mounting onto DIN-rail 35 mm. If it is requested to place devices of different frame size side by side, it is possible to use for compensation of differences in height mounting depth spacers WG which assure the same position of front panel towards front plate.

For connection of conductors there are available various types of box and tunnel terminals MC.

# Accessories for MCCBs Ex9M

## Auxiliary and signal contact units

- Contact units for auxiliary and signal contact functions are suitable for all frame sizes
- Auxiliary contacts synchronous with main contacts of the circuit breaker
- Signal contacts active on electrical tripping of the circuit breaker (tripping signal contacts)
- It is possible to use 1 unit AL21 plus up to four units of AX21 in one MCCBs (depends on frame size)



Function	Frame size	Contacts	Article No.	Type	Packing
Auxiliary	all	1 CO	101395	AX21	1/24
Signal	all	1 CO	101396	AL21	1/24

Technical data p. 151

## Early-make auxiliary contacts

- Used mainly for interlocking, load shedding or emergency off application circuits
- Does not limit using of voltage releases and motor operator
- It is possible to use 1 unit EC 2i in one MCCBs
- Compatible with MCCB devices produced from 3/2014 only!  
Please, note the requirement for early-make contact function in the order of MCCB!



Function	Frame size	Contacts	Article No.	Type	Packing
Early-make aux.	M1, M2	1 NO	106315	EC 21	1
Early-make aux.	M3, M4, M5	1 NO	106317	EC 23	1

Technical data p. 152

## Shunt trip releases

- It is possible to use one unit of shunt trip release SHT2i or one unit of undervoltage release UVT2i



Aux. cont.	Frame size	Operating Voltage	Article No.	Type	Packing
-	M1	48V AC	101397	SHT21 AC48V	1/24
-	M1	110V AC	101398	SHT21 AC110V	1/24
-	M1	220-240V AC	101399	SHT21 AC220-240V	1/24
-	M1	380-415V AC	101400	SHT21 AC380-415V	1/24
-	M1	24V DC	101401	SHT21 DC24V	1/24
-	M1	48V DC	101402	SHT21 DC48V	1/24
-	M1	110-120V DC	101403	SHT21 DC110V	1/24
-	M1	220V DC	101405	SHT21 DC220V	1/24
-	M2, M3	48V AC	101416	SHT22 AC48V	1/24
-	M2, M3	110V AC	101417	SHT22 AC110V	1/24
-	M2, M3	220-240V AC	101418	SHT22 AC220-240V	1/24
-	M2, M3	380-415V AC	101419	SHT22 AC380-415V	1/24
-	M2, M3	24V DC	101420	SHT22 DC24V	1/24
-	M2, M3	48V DC	101421	SHT22 DC48V	1/24
-	M2, M3	110-120V DC	101422	SHT22 DC110V	1/24
-	M2, M3	220V DC	101424	SHT22 DC220V	1/24
-	M4, M5	110V AC	103723	SHT24 AC110V	1/12
-	M4, M5	220-240V AC	103724	SHT24 AC220-240V	1/12
-	M4, M5	380-415V AC	103725	SHT24 AC380-415V	1/12
-	M4, M5	24V DC	103729	SHT24 DC24V	1/12
-	M4, M5	48V DC	103730	SHT24 DC48V	1/12
-	M4, M5	110-120V DC	103727	SHT24 DC110V	1/12
-	M4, M5	220V DC	103728	SHT24 DC220V	1/12

Technical data p. 154



# Accessories for MCCBs Ex9M

## Undervoltage releases

- It is possible to use one unit of undervoltage release UVT2*i* or one unit of shunt trip release SHT2*i*



Aux. cont.	Frame size	Operating Voltage	Article No.	Type	Packing
-	M1	220-240V AC	101406	UVT21 220-240V AC	1/24
-	M1	380-415V AC	101407	UVT21 380-415V AC	1/24
-	M2, M3	220-240V AC	101425	UVT22 220-240V AC	1/24
-	M2, M3	380-415V AC	101426	UVT22 380-415V AC	1/24
-	M4, M5	110V AC	103733	UVT24 AC110V	1/12
-	M4, M5	220-240V AC	103734	UVT24 AC220-240V	1/12
-	M4, M5	380-415V AC	103735	UVT24 AC380-415V	1/12
-	M4, M5	110-120V DC	103736	UVT24 DC110-120V	1/12
-	M4, M5	220V DC	103737	UVT24 DC220V	1/12
-	M4, M5	24V DC	103738	UVT24 DC24V	1/12
-	M4, M5	48V DC	103739	UVT24 DC48V	1/12

Technical data p. 155

## Remote operators

- Motor drives for electrical and remote control of MCCBs
- Available for all frame sizes



Frame size	Operating Voltage	Article No.	Type	Packing
M1	230 V AC	101411	MOD21 AC230V	1/8
M1	110 V AC	101412	MOD21 AC110V	1/8
M1	220 V DC	101413	MOD21 DC220V	1/8
M1	110 V DC	101414	MOD21 DC110V	1/8
M1	24 V DC	101415	MOD21 DC24V	1/8
M2	230 V AC	101430	MOD22 AC230V	1/8
M2	110 V AC	101431	MOD22 AC110V	1/8
M2	220 V DC	101432	MOD22 DC220V	1/8
M2	110 V DC	101433	MOD22 DC110V	1/8
M2	24 V DC	101434	MOD22 DC24V	1/8
M3	230 V AC	101484	MOD23 AC230V	1/4
M3	110 V AC	101485	MOD23 AC110V	1/4
M3	220 V DC	101486	MOD23 DC220V	1/4
M3	110 V DC	101487	MOD23 DC110V	1/4
M3	24 V DC	101488	MOD23 DC24V	1/4
M4, M5	230 V AC	103743	MOD24 AC230V	1/2
M4, M5	110 V AC	103744	MOD24 AC110V	1/2
M4, M5	220 V DC	103745	MOD24 DC220V	1/2
M4, M5	110 V DC	103746	MOD24 DC110V	1/2
M4, M5	24 V DC	103747	MOD24 DC24V	1/2

Technical data p. 159

# Accessories for MCCBs Ex9M

## Direct rotary handles

- Rotary handle for direct mounting onto breaker
- Scope of delivery: mechanism block, rotary handle
- Indication of connected breaker status ON-OFF-TRIP
- Degree of protection IP40, IK07
- Can be locked in ON and OFF position with up to three padlocks (not in a scope of delivery)



Frame size	Colour	Article No.	Type	Packing
M1	Grey	101410	RHD21	1/36
M2	Grey	101429	RHD22	1/18
M3	Grey	101483	RHD23	1/9
M4, M5	Grey	103742	RHD24	1/6

Technical data p. 156

## Extended rotary handles

- Rotary handle with extension shaft (extension shaft can be shortened)
- Possibility of longer extension shaft 500 mm (only the shaft as separated item)
- Scope of delivery: mechanism block, extension shaft, rotary handle
- Indication of connected breaker status ON-OFF-TRIP
- Degree of protection IP54, IK08
- Can be locked in ON and OFF position with up to three padlocks (not in a scope of delivery)



Frame size	Length	Colour	Article No.	Type	Packing
M1	300 mm	Grey	101409	ERH21	1/6
M2	300 mm	Grey	101428	ERH22	1/6
M3	300 mm	Grey	101482	ERH23	1/6
M4, M5	300 mm	Grey	103741	ERH24	1/4
All (only the shaft)	500 mm	-	110189	ERH2x ES 500mm	1/50

Technical data p. 157

## Phase barriers

- Phase barriers to avoid short circuit due to ionised gas during tripping off of the breaker when unisolated busbars are used for its connection
- In the scope of delivery of MCCBs, separately orderable as a spare part
- Set consists of appropriate number of barriers suitable for both sides MCCB



Frame size	Poles	Article No.	Type	Packing
M1	3P	101441	PB21 3P	1 set
M2	3P	101444	PB22 3P	1 set
M3	3P	101491	PB23 3P	1 set
M4, M5	3P	103751	PB24 3P	1 set
M1	4P	104852	PB21 4P	1 set
M2	4P	104853	PB22 4P	1 set
M3	4P	104854	PB23 4P	1 set
M4, M5	4P	104856	PB24 4P	1 set

# Accessories for MCCBs Ex9M

## Connection terminals

- Connection terminals for MCCBs of all frame sizes
- Box and tunnel terminal versions
- For connecting with Al or Cu wires (box terminals only for Cu wires)
- Packed separately (for 3P connection, it is necessary to order 3pcs of terminal)
- Box terminals newly in the scope of delivery of AC devices M1, M2

### Box terminals



Frame size	Version	Terminals	Max. terminal capacity	Article No.	Type	Packing
M1	box	1	4-95 mm <sup>2</sup>	103705	MC21	1 pc
M2	box	1	10-120 mm <sup>2</sup>	103709	MC22	1 pc
M3	box	1	120-240 mm <sup>2</sup>	103715	MC23	1 pc
M3	box	1	120-240 mm <sup>2</sup>	103717	MC23 UL	1 pc

### Tunnel terminals



Frame size	Version	Terminals	Max. terminal capacity	Article No.	Type	Packing
M1	tunnel	1	16-95 mm <sup>2</sup>	103707	MC21 W	1 pc
M2	tunnel	1	35-240 mm <sup>2</sup>	103869	MC22 W	1 pc
M2	tunnel	2	35-120 mm <sup>2</sup>	103711	MC22 W2	1 pc
M2	tunnel	6	10-35 mm <sup>2</sup>	103713	MC22 W6	1 pc
M3	tunnel	2	120-240 mm <sup>2</sup>	103719	MC23 W2	1 pc
M3	tunnel	2	120-240 mm <sup>2</sup>	103871	MC23 W2 UL	1 pc
M3	tunnel	4	35-95 mm <sup>2</sup>	103721	MC23 W4	1 pc
M4, M5	tunnel	2	120-240 mm <sup>2</sup>	106314	MC24 W2	1 pc

### Screw terminals



Frame size	Version	Terminals	Screw size	Article No.	Type	Packing
M1	screw	1	M6	107873	MCS21	1 pc
M2	screw	1	M8	107874	MCS22	1 pc

Technical data p. 161

## Terminal covers, short

- Terminal covers to increase touch protection of terminals



Frame size	Poles	Article No.	Type	Packing
M1	3P	101439	TCV21 3P	1 pc
M2	3P	101442	TCV22 3P	1 pc
M3	3P	101489	TCV23 3P	1 pc
M4, M5	3P	103748	TCV24 3P	1 pc
M1	4P	102372	TCV21 4P	1 pc
M2	4P	102374	TCV22 4P	1 pc
M3	4P	102376	TCV23 4P	1 pc
M4, M5	4P	103750	TCV24 4P	1 pc

# Accessories for MCCBs Ex9M

## Terminal covers, long

- Terminal covers to increase touch protection of terminals



Frame size	Poles	Article No.	Type	Packing
M1	3P	101440	TCE21 3P	1 pc
M2	3P	101443	TCE22 3P	1 pc
M3	3P	101490	TCE23 3P	1 pc
M4, M5	3P	103749	TCE24 3P	1 pc
M1	4P	102373	TCE21 4P	1 pc
M2	4P	102375	TCE22 4P	1 pc
M3	4P	102377	TCE23 4P	1 pc
M4, M5	4P	104855	TCE24 4P	1 pc

## DIN-rail adaptors

- Adaptors for mounting of MCCBs onto DIN-rail 35 mm
- Suitable for all variants of MCCBs and MCCB Switch Disconnectors of given frame size



Frame size	Poles	Article No.	Type	Packing
M1	3P, 4P	106319	DRA21	1
M2	3P, 4P	106320	DRA22	1

Technical data p. 162

## Mounting depth spacers

- Set of mounting depth spacers for compensation of differences in height between frame sizes
- Assures the same position of front panel towards front plate
- Two variants with height 10 and 13 mm
- For compensation of heights please use these configuration:
  - M1 -> M2 = 1x WG10
  - M1 -> M3 = 1x WG10 + 2x WG13
  - M1 -> M4, M5 = 1x WG10 + 3x WG13
  - M2 -> M3 = 2x WG13
  - M2 -> M4, M5 = 3x WG13
  - M3 -> M4, M5 = 1x WG13



Frame size	Height	Article No.	Type	Packing
M1	10 mm	106321	WG 10	1 set
M2, M3, M4, M5	13 mm	106362	WG 13	1 set

Technical data p. 163

## Mounting sets for MF line of sheet steel enclosures

- There are available tailored mounting panels and front plates for MCCBs and Disconnectors of size M1 and M2 as accessories of metal enclosures of line MF.
- Mounting plates are drilled with threads for easy mounting of MCCBs
- Front plates with particular device cut out for M1 and M2 devices (3P and 4P, vertical or horizontal position)
- For more details, please see catalogue "CONSUMER UNITS"

# Accessories for electronic MCCBs Ex9M6

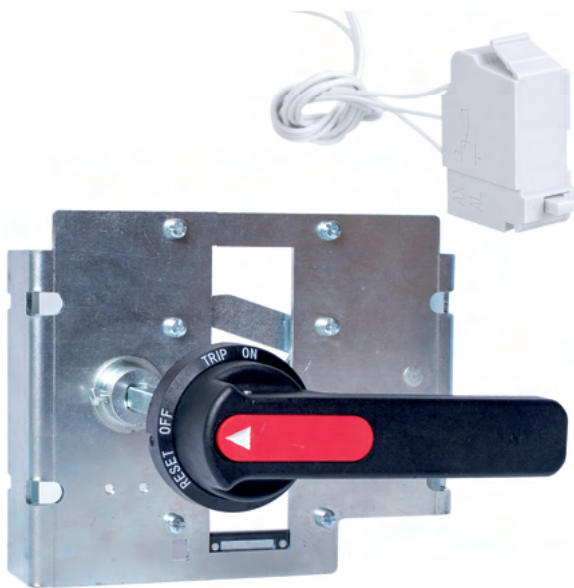

- Accessories for Ex9M6 line devices
- Auxiliary contacts synchronous with main contacts
- Signal contacts active on electrical tripping of the circuit breaker (tripping signal contacts)
- Shunt trip and undervoltage releases
- Rotary handle
- Extended handle
- Connection terminals

Accessories suitable for Moulded Case Circuit Breakers Ex9M6. It is possible to supplement or modify functions of a basic circuit breaker by the installation of suitable accessories.

Circuit breakers can be equipped with two auxiliary contacts AX21 and one unit of signal contact AL21. The device can be controlled by the shunt trip release SHT and the undervoltage release UVT. The closing release XF is only suitable for the MOD version.

The circuit breakers can also be equipped with an extended handle for easier operation of the toggle and an extended rotatory handle for different applications e.g. for door coupling.

Mounting of the device onto plate can be done directly.

# Accessories for electronic MCCBs Ex9M6

## Auxiliary and signal contact units

- Auxiliary contacts synchronous with main contacts of the circuit breaker
- Signal contacts active on electrical tripping of the circuit breaker (tripping signal contacts)



Function	Suitable MCCB	Contacts	Article No.	Type	Packing
Auxiliary	all	1 CO	101395	AX21	1/24
Signal	all (except SD)	1 CO	101396	AL21	1/24

Technical data p. 164

## Shunt trip releases

- It is possible to use one unit of shunt trip release SHT26



Suitable MCCB	Operating Voltage	Article No.	Type	Packing
all M6 size	24V DC	110460	SHT26 DC24V	1/3
all M6 size	48V DC	110461	SHT26 DC48V	1/3
all M6 size	110V DC	110462	SHT26 DC110V	1/3
all M6 size	220V DC	110463	SHT26 DC220V	1/3
all M6 size	48V AC	110464	SHT26 AC48V	1/3
all M6 size	110V AC	110465	SHT26 AC110V	1/3
all M6 size	220 - 240V AC	110466	SHT26 AC220-240V	1/3
all M6 size	380 - 415V AC	110467	SHT26 AC380-415V	1/3

Technical data p. 165

## Undervoltage releases

- It is possible to use one unit of undervoltage release UVT26



Suitable MCCB	Operating Voltage	Article No.	Type	Packing
all M6 size	220 - 240 V AC	110468	UVT26 AC220-240V	1/3
all M6 size	380 - 415 V AC	110469	UVT26 AC380-415V	1/3

Technical data p. 166

# Accessories for electronic MCCBs Ex9M6

## Extended rotary handle

- Rotary handle with extension shaft
- Scope of delivery: mechanism block, extension shaft, rotary handle
- Indication of connected breaker status ON-OFF-TRIP
- Can be locked in ON and OFF position



Suitable MCCB	Shaft length	Handle colour	Article No.	Type	Packing
Ex9M6/SD	150 mm	Black	110718	ERH26	1/2

Technical data p. 167

## Extended handle

- For easier operation of the toggle



Suitable MCCB	Colour	Article No.	Type	Packing
Ex9M6/SD	Grey	110698	LHD26	1/20

Technical data p. 168

## Front connection plate

- Front connection plate for frame size M6
- Set is for connection from one side



Suitable MCCB	Poles	Rated current	Article No.	Type	Packing
all M6 size	3P	800-1250	110694	JP26 3P 800-1250	1 set
all M6 size	3P	1600	110695	JP26 3P 1600	1 set
all M6 size	4P	800-1250	110696	JP26 4P 800-1250	1 set
all M6 size	4P	1600	110697	JP26 4P 1600	1 set

# Notes

A large grid of dashed lines for taking notes, consisting of 20 columns and 30 rows.



# Accessories for MCCBs Ex9MV2S



- Accessories for Ex9MV2S line devices
- Auxiliary contacts synchronous with main contacts
- Signal contacts active on electrical tripping of the circuit breaker (tripping signal contacts)
- Shunt trip releases
- Rotary handles

Accessories suitable for PV Moulded Case Circuit Breakers Ex9MV2S. It is possible to supplement or modify functions of a basic circuit breaker by the installation of suitable accessories.

Circuit breakers can be equipped with auxiliary contacts AX22V (or 2AX22V) and one unit of signal contact AL22 or a combination of both AX+AL22V. Accessories are mounted into specific positions, for this reason parts mounted on the right side are named with a -R in the product name (2AX22VR). One unit of shunt trip release SHT22VR can be installed in the breaker.

The circuit breakers can also be equipped with an extended rotatory handle for different operation of the toggle, e.g. for door coupling.

Mounting of the device onto plate can be done directly.

# Accessories for MCCBs Ex9MV2S

## Auxiliary and signal contact units

- Auxiliary contacts synchronous with main contacts of the circuit breaker
- Signal contacts active on electrical tripping of the circuit breaker (tripping signal contacts)



Function	Suitable MCCB	Contacts	Article No.	Type	Packing
Auxiliary	Ex9MV2S	1 CO	110199	AX22V	1/8
Auxiliary	Ex9MV2S	2 CO	110200	2AX22V	1/8
Signal	Ex9MV2S	1 CO	110201	AL22V	1/8
Auxiliary + Signal	Ex9MV2S	2 CO	110202	AX+AL22V	1/8
Auxiliary	Ex9MV2S	1 CO	110206	AX22VR	1/8
Auxiliary	Ex9MV2S	2 CO	110207	2AX22VR	1/8

Technical data p. 169

## Shunt trip releases

- It is possible to use one unit of shunt trip release SHT22VR on the right side of the MCCB



Aux. cont.	Suitable MCCB	Operating Voltage	Article No.	Type	Packing
-	Ex9MV2S	24V DC	110208	SHT22VR DC24V	1/8
-	Ex9MV2S	230V AC	110209	SHT22VR AC230V	1/8
-	Ex9MV2S	400V AC	110210	SHT22VR AC400V	1/8

Technical data p. 170

## Extended rotary handles

- Rotary handle with extension shaft (extension shaft can be shortened)
- Scope of delivery: mechanism block, extension shaft, rotary handle
- Indication of connected breaker status ON-OFF-TRIP
- Can be locked in ON and OFF position



Suitable MCCB	Length	Colour	Article No.	Type	Packing
Ex9MV2S	300 mm	Black	110211	ERH-1	1

Technical data p. 171

# Technical Data

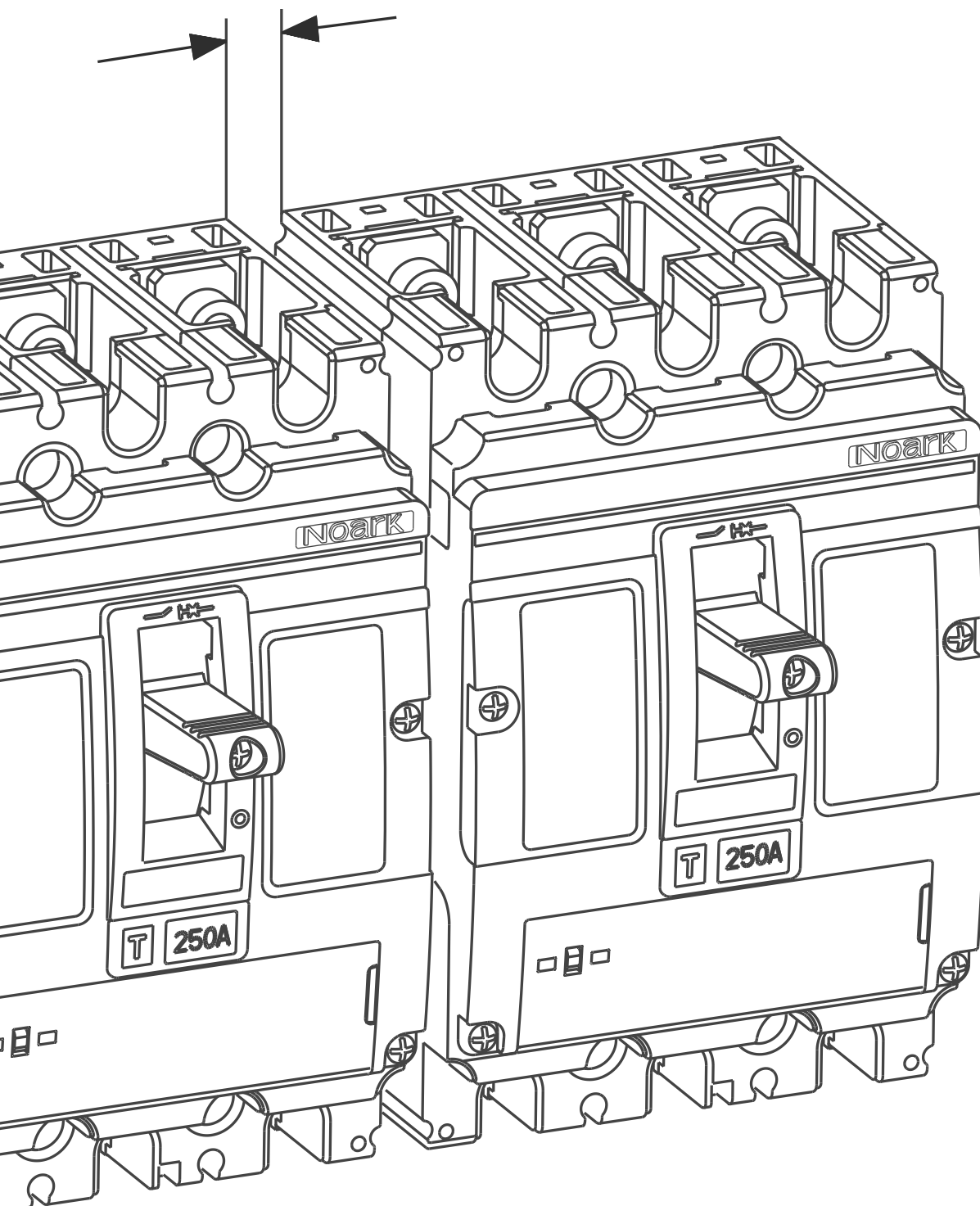

# Contents

## Technical data

<b>Moulded Case Circuit Breakers Ex9M</b>	
frame size M1 up to 125 A .....	75
frame size M2 up to 250 A .....	78
frame size M3 up to 400 A .....	81
frame size M4 up to 630 A .....	84
frame size M5 up to 800 A .....	87
frame size M6 up to 1600 A .....	90
frame size M6 MOD (motor operated) up to 1600 A .....	94
<b>MCCB Switch Disconnectors Ex9MSD AC</b>	
frame size M1 up to 125 A .....	100
frame size M2 up to 250 A .....	103
frame size M3 up to 400 A .....	106
frame size M4 up to 630 A .....	109
frame size M5 up to 800 A .....	112
frame size M6 up to 1600 A .....	115
<b>DC Moulded Case Circuit Breakers Ex9M</b>	
frame size M1 up to 125 A .....	118
frame size M2 up to 250 A .....	121
frame size M3 up to 400 A .....	124
frame size M4 up to 630 A .....	127
frame size M5 up to 800 A .....	130
Ex9MV2S for PV .....	133
<b>DC MCCB Switch Disconnectors Ex9MSD DC</b>	
frame size M1 up to 125 A .....	136
frame size M2 up to 250 A .....	139
frame size M3 up to 400 A .....	142
frame size M4 up to 630 A .....	145
frame size M5 up to 800 A .....	148
<b>Accessories for MCCBs</b>	
<i>Accessories for Ex9M1-5</i>	
Auxiliary and signal contact units AX21, AL21 .....	151
Early-make auxiliary contacts EC .....	152
Shunt trip releases SHT2 .....	154
Undervoltage releases UVT2 .....	155
Direct rotary handles RHD2 .....	156
Extended rotary handles ERH2 .....	157
Remote operators MOD2 .....	159
Connection terminals MC2 .....	161
DIN-rail mounting adaptors DRA2 .....	162
Mounting depth spacers WG .....	163
<i>Accessories for Ex9M6</i>	
Auxiliary and signal contact units AX21, AL21 .....	164
Shunt trip releases SHT26 .....	165
Undervoltage releases UVT26 .....	166
Extended rotary handle ERH26 .....	167
Extended handle LHD26 .....	168
<i>Accessories for Ex9MV2S</i>	
Auxiliary and signal contact units AX22, AL22 .....	169
Shunt trip releases SHT22.....	170
Extended rotary handle ERH-1 .....	171

# Technical Data Ex9M1

## Moulded Case Circuit Breakers up to 125 A

### General parameters

Suitable for household as well as industrial applications		
Thermal release adjustable $(0.8-0.9-1) \times I_n$		
Instantaneous short-circuit current release fixed $10 \times I_n$		
Internal accessories		
Auxiliary contact unit	AX21	101395
Alarm contact unit	AL21	101396
Early-make auxiliary contact	EC 21	106317
Shunt trip releases	SHT21	101397-101405
Undervoltage releases	UVT21	101406-101407
Max. number of installed internal accessories is 2 pcs of AX21, 1 pc of AL21 or EC 21 and 1 pc of a release (SHT21 or UVT21)		
External accessories		
Direct rotary handle	RHD21	101410
Extended rotary handle	ERH21	101409
Remote motor operators	MOD21	101411-101415
Terminal cover, short	TCV21 3P, 4P	101439, 102372
Terminal cover, long	TCE21 3P, 4P	101440, 102373
Phase barrier set	PB21 3P, 4P	101441, 104852
Connection terminals	MC21	103705-103708
DIN-rail adaptor	DRA21	106319
Mounting screws, box terminals as well as phase barriers in the scope of delivery		

### Electrical parameters

	Ex9M1S	Ex9M1N	Ex9M1H	Ex9M1P
Tested according to	IEC/EN 60947-2			
Rated op. voltage $U_e$	415/690 V AC			
Rated insulation voltage $U_i$	800 V			
Rated impulse withstand voltage $U_{imp}$	8 kV			
Rated frequency	50/60 Hz			
Rated ultimate short-circuit breaking capacity $I_{cu}$	36 kA / 415 V 5 kA / 690 V	50 kA / 415 V 5 kA / 690 V	100 kA / 415 V 6 kA / 690 V	150 kA / 415 V 8 kA / 690 V
Rated service short-circuit breaking capacity $I_{cs}$	36 kA / 415 V 5 kA / 690 V	50 kA / 415 V 5 kA / 690 V	100 kA / 415 V 6 kA / 690 V	150 kA / 415 V 8 kA / 690 V
Rated short-circuit making capacity $I_{cm}$	75.6 kA / 415 V 7.5 kA / 690 V	105 kA / 415 V 7.5 kA / 690 V	220 kA / 415 V 9 kA / 690 V	330 kA / 415 V 13.6 kA / 690 V
Rated current	16 — 125 A			
Overvoltage category	III / 3			
Utilization category	A			
Mechanical service life	15 000 operation cycles			
Electrical service life	5 000 operation cycles			
Maximum frequency of switch. cycles	120 operating cycles per hour			
Total disconnection time at short circuit	< 2 ms			
Internal resistance per pole at 125 A	0.80 mΩ			
Power loss per pole at 125 A	12.5 W			
Line voltage connection	arbitrary above or below			

# Technical Data Ex9M1

## Moulded Case Circuit Breakers up to 125 A

### Mechanical parameters

Device width 3P / 4P	90 mm / 120 mm
Device height	140 mm
Device depth	81.6 mm
Mounting	onto panel
Degree of protection	IP40, IP20 terminals
Terminals	box
Terminal capacity	4 — 95 mm <sup>2</sup>
Fastening torque of terminals	8 Nm
Ambient temperature	-25 — +70 °C
Altitude	≤ 2 000 m
Relative humidity	≤ 50 % at 40 °C, ≤ 90 % monthly average
Resistance to humidity and heat	class 2
Pollution degree	3
Weight 3P / 4P	1.2 kg / 1.7 kg
Mounting position	vertical, can be rotated by 90° in each axis

### Wiring diagram

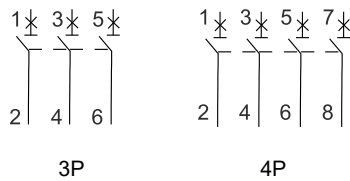

### Dimensions

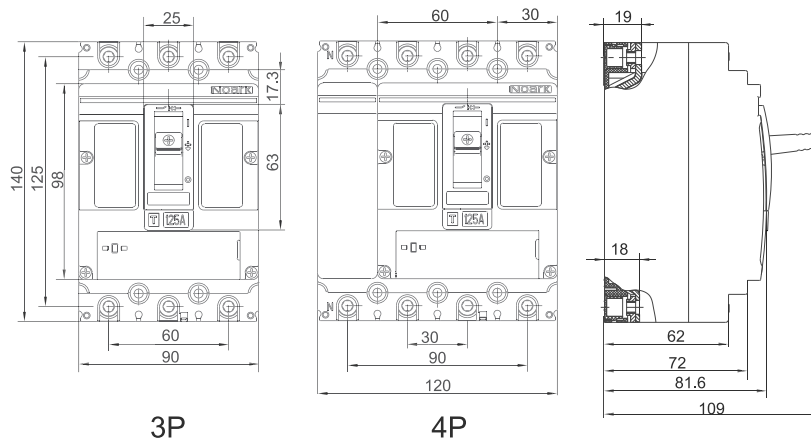

# Technical Data Ex9M1

Moulded Case Circuit Breakers up to 125 A

## Installation space

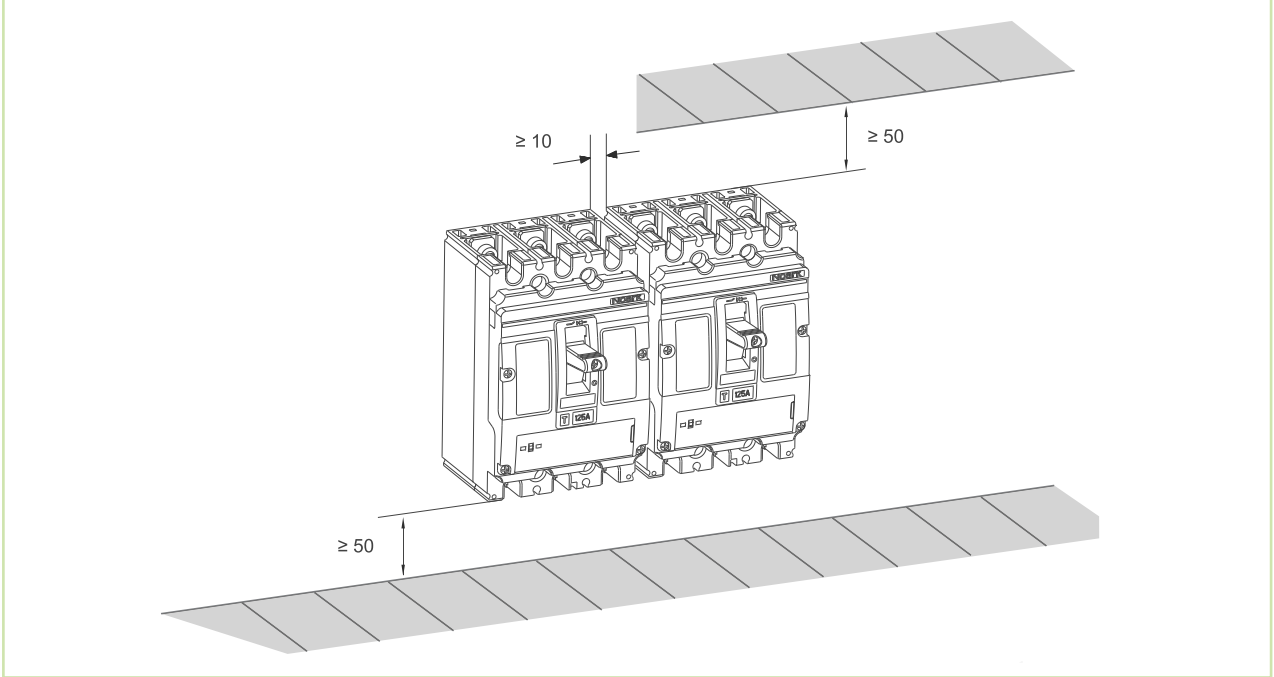

## Tripping characteristics

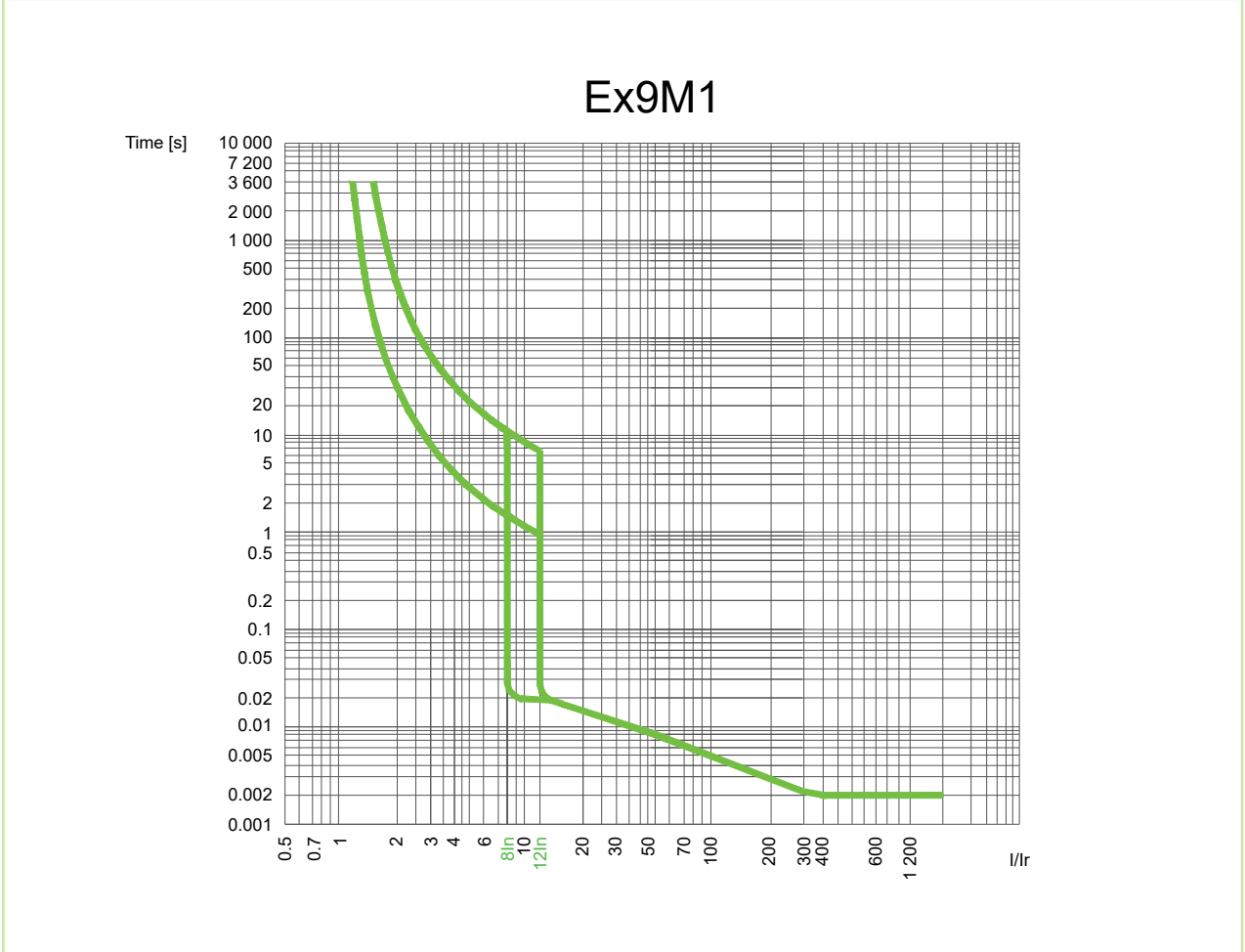

# Technical Data Ex9M2

## Moulded Case Circuit Breakers up to 250 A

### General parameters

Suitable for household as well as industrial applications

Thermal release adjustable  $(0.8-0.9-1) \times I_n$

Instantaneous short-circuit current release  $(5-6-7-8-9-10) \times I_n$

Internal accessories

Auxiliary contact unit	AX21	101395
Alarm contact unit	AL21	101396
Early-make auxiliary contact	EC 21	106317
Shunt trip releases	SHT22	101416-101424
Undervoltage releases	UVT22	101425-101426

Max. number of installed internal accessories is 2 pcs of AX21, 1 pc of AL21 or EC 21 and 1 pc of a release (SHT22 or UVT22)

External accessories

Direct rotary handle	RHD22	101429
Extended rotary handle	ERH22	101428
Remote motor operators	MOD22	101430-101434
Terminal cover, short	TCV22 3P, 4P	101442, 102374
Terminal cover, long	TCE22 3P, 4P	101443, 102375
Phase barrier set	PB22 3P, 4P	101444, 104853
Connection terminals	MC22	103709-103714
DIN-rail adaptor	DRA22	106320

Mounting screws, box terminals as well as phase barriers in the scope of delivery

### Electrical parameters

	Ex9M2S	Ex9M2N	Ex9M2H	Ex9M2P
Tested according to	IEC/EN 60947-2			
Rated op. voltage $U_e$	415/690 V AC			
Rated insulation voltage $U_i$	800 V			
Rated impulse withstand voltage $U_{imp}$	8 kV			
Rated frequency	50/60 Hz			
Rated ultimate short-circuit breaking capacity $I_{cu}$	36 kA / 415 V 6 kA / 690 V	50 kA / 415 V 6 kA / 690 V	100 kA / 415 V 8 kA / 690 V	150 kA / 415 V 10 kA / 690 V
Rated service short-circuit breaking capacity $I_{cs}$	36 kA / 415 V 6 kA / 690 V	50 kA / 415 V 6 kA / 690 V	100 kA / 415 V 8 kA / 690 V	150 kA / 415 V 10 kA / 690 V
Rated short-circuit making capacity $I_{cm}$	75.6 kA / 415 V 7.5 kA / 690 V	105 kA / 415 V 7.5 kA / 690 V	220 kA / 415 V 9 kA / 690 V	330 kA / 415 V 13.6 kA / 690 V
Rated current	125 — 250 A			
Overvoltage category	III / 3			
Utilization category	A			
Mechanical service life	15 000 operation cycles			
Electrical service life	5 000 operation cycles			
Maximum frequency of switch. cycles	120 operating cycles per hour			
Total disconnection time at short circuit	< 2 ms			
Internal resistance per pole at 250 A	0.40 mΩ			
Power loss per pole at 250 A	25 W			
Line voltage connection	arbitrary above or below			



# Technical Data Ex9M2

## Moulded Case Circuit Breakers up to 250 A

### Mechanical parameters

Device width 3P / 4P	105 mm / 140 mm
Device height	157 mm
Device depth	91.5 mm
Mounting	onto panel
Degree of protection	IP40, IP20 terminals
Terminals	box
Terminal capacity	10 — 120 mm <sup>2</sup>
Fastening torque of terminals	25 Nm
Ambient temperature	-25 — +70 °C
Altitude	≤ 2 000 m
Relative humidity	≤ 50 % at 40 °C, ≤ 90 % monthly average
Resistance to humidity and heat	class 2
Pollution degree	3
Weight 3P / 4P	1.7 kg / 2.2 kg
Mounting position	vertical, can be rotated by 90° in each axis

### Wiring diagram

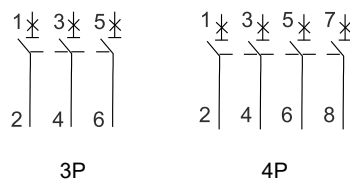

### Dimensions

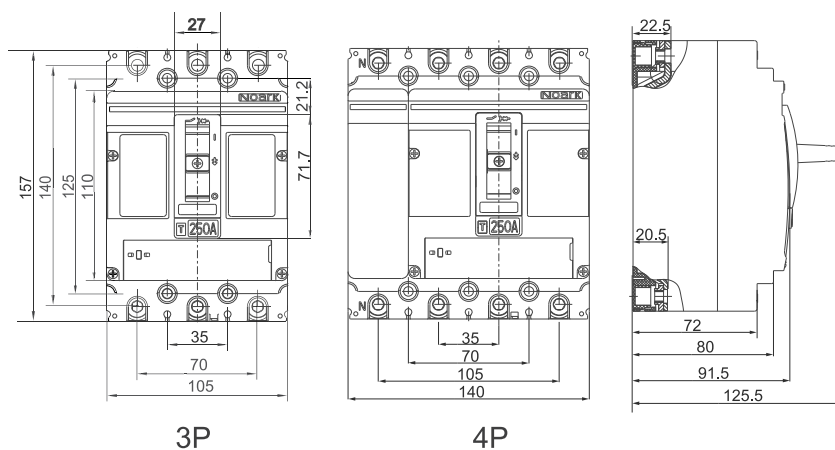

# Technical Data Ex9M2

## Moulded Case Circuit Breakers up to 250 A

### Installation space

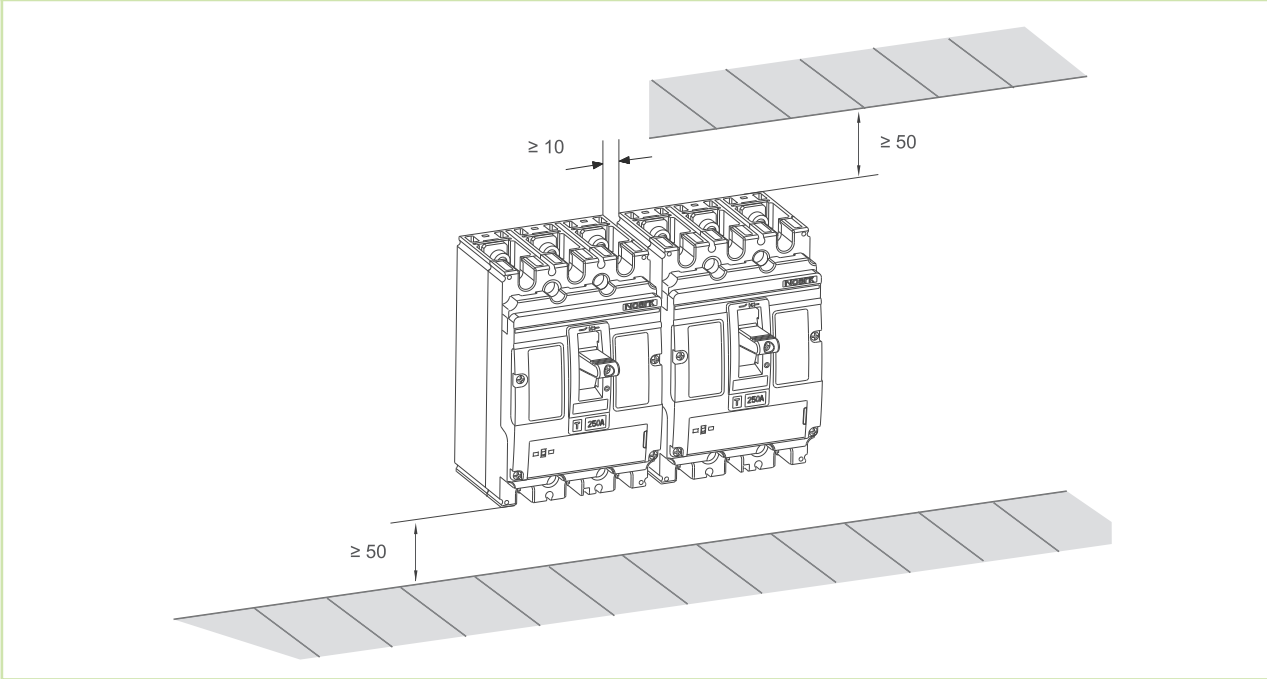

### Tripping characteristics

## Ex9M2

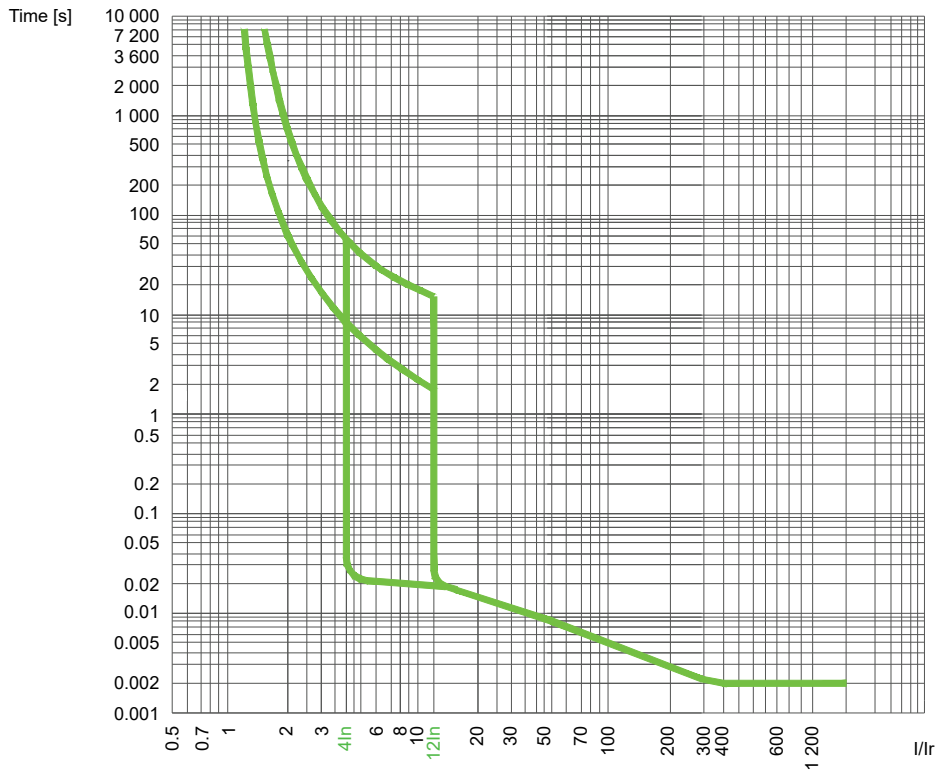

# Technical Data Ex9M3

## Moulded Case Circuit Breakers up to 400 A

### General parameters

Suitable for household as well as industrial applications

Thermal release adjustable  $(0.8-0.9-1) \times I_n$

Instantaneous short-circuit current release  $(5-6-7-8-9-10) \times I_n$

Internal accessories

Auxiliary contact unit	AX21	101395
Alarm contact unit	AL21	101396
Early-make auxiliary contact	EC 23	106317
Shunt trip releases	SHT22	101416-101424
Undervoltage releases	UVT22	101425-101426

Max. number of installed internal accessories is 3 pcs of AX21, 1 pc of AL21 or EC 23 and 1 pc of a release (SHT22 or UVT22)

External accessories

Direct rotary handle	RHD23	101483
Extended rotary handle	ERH23	101482
Remote motor operators	MOD23	101484-101488
Terminal cover, short	TCV23 3P, 4P	101489, 102376
Terminal cover, long	TCE23 3P, 4P	101490, 102377
Phase barrier set	PB23 3P, 4P	101491, 104854
Connection terminals	MC23	103715-103722

Mounting screws as well as phase barriers in the scope of delivery

### Electrical parameters

	Ex9M3S	Ex9M3N	Ex9M3H	Ex9M3P
Tested according to	IEC/EN 60947-2			
Rated op. voltage $U_e$	415/690 V AC			
Rated insulation voltage $U_i$	800 V			
Rated impulse withstand voltage $U_{imp}$	8 kV			
Rated frequency	50/60 Hz			
Rated ultimate short-circuit breaking capacity $I_{cu}$	36 kA / 415 V 6 kA / 690 V	50 kA / 415 V 6 kA / 690 V	100 kA / 415 V 8 kA / 690 V	150 kA / 415 V 10 kA / 690 V
Rated service short-circuit breaking capacity $I_{cs}$	36 kA / 415 V 3 kA / 690 V	50 kA / 415 V 3 kA / 690 V	100 kA / 415 V 4 kA / 690 V	150 kA / 415 V 5 kA / 690 V
Rated short-circuit making capacity $I_{cm}$	75.6 kA / 415 V 7.5 kA / 690 V	105 kA / 415 V 7.5 kA / 690 V	220 kA / 415 V 9 kA / 690 V	330 kA / 415 V 13.6 kA / 690 V
Rated current	250 — 400 A			
Overvoltage category	III			
Utilization category	A			
Mechanical service life	10 000 operation cycles			
Electrical service life	2 000 operation cycles			
Maximum frequency of switch. cycles	60 cycles per hour			
Total disconnection time at short circuit	< 2 ms			
Internal resistance per pole at 400 A	0.15 mΩ			
Power loss per pole at 400 A	24 W			
Line voltage connection	arbitrary above or below			

# Technical Data Ex9M3

## Moulded Case Circuit Breakers up to 400 A

### Mechanical parameters

Device width 3P / 4P	140 mm / 185 mm
Device height	255 mm
Device depth	118.5 mm
Mounting	onto panel
Degree of protection	IP40, IP20 terminals
Terminals	M10 screws
Busbar thickness	≤ 8 mm
Busbar width	≤ 30 mm
Cable lug width	≤ 30 mm
Fastening torque of terminals	25 — 30 Nm
Ambient temperature	-25 — +70 °C
Altitude	≤ 2 000 m
Relative humidity	≤ 50 % at 40 °C, ≤ 90 % monthly average
Resistance to humidity and heat	class 2
Pollution degree	3
Weight 3P / 4P	5 kg / 6.6 kg
Mounting position	vertical, can be rotated by 90° in each axis

### Wiring diagram

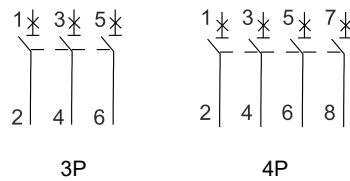

### Dimensions

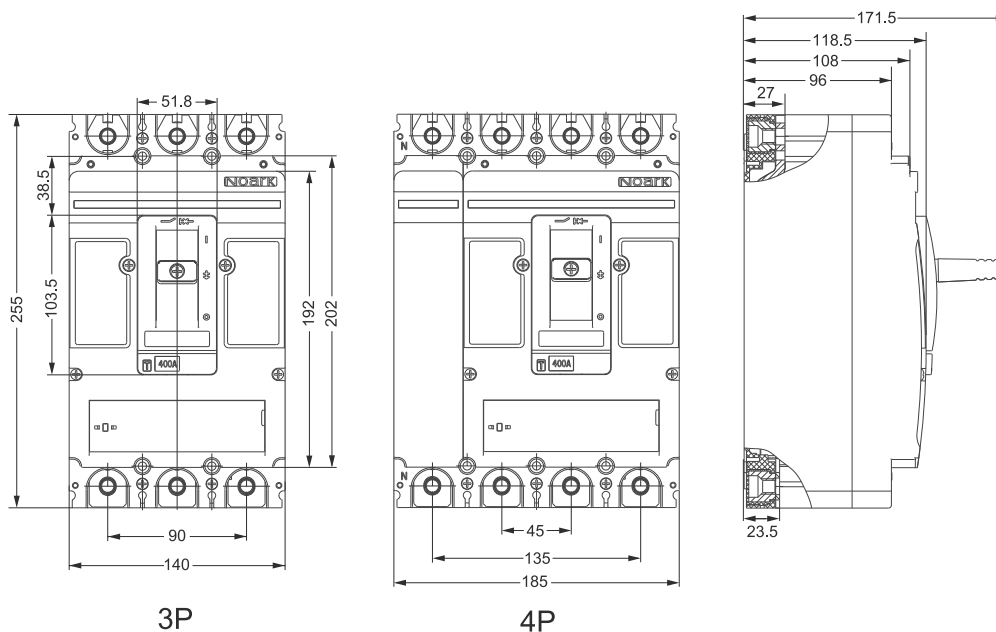

Ordering information p. 12

# Technical Data Ex9M3

## Moulded Case Circuit Breakers up to 400 A

### Installation space

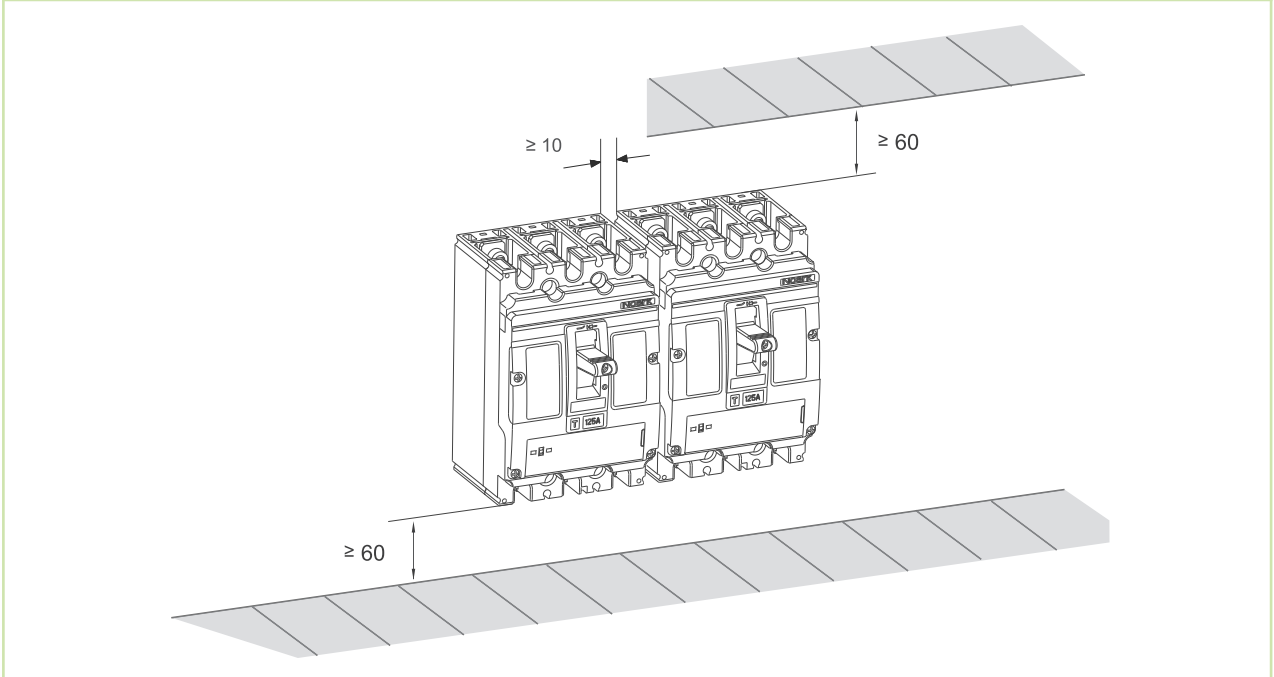

### Tripping characteristics

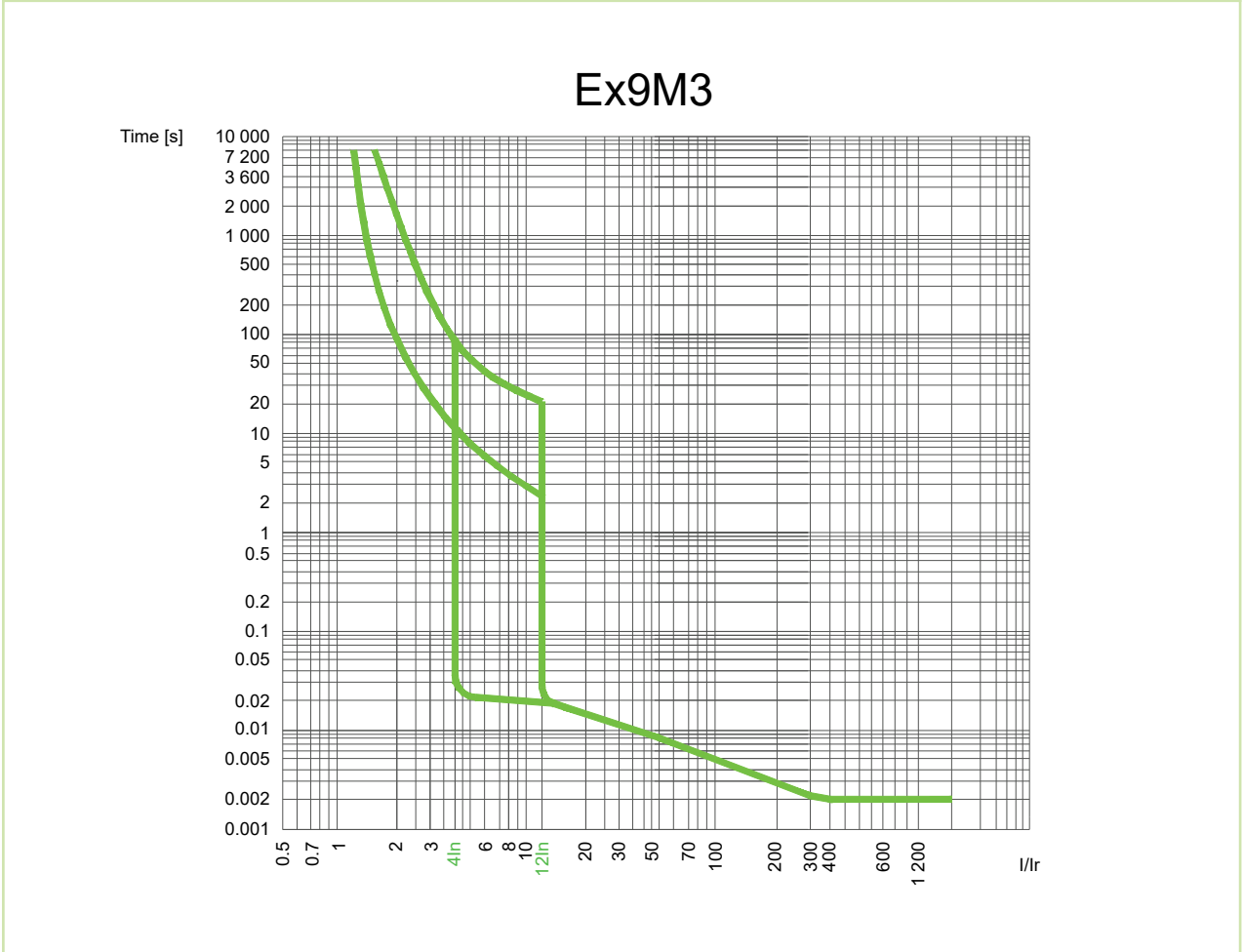

# Technical Data Ex9M4

## Moulded Case Circuit Breakers up to 630 A

### General parameters

Suitable for industrial applications

Thermal release adjustable  $(0.8-0.9-1) \times I_n$

Instantaneous short-circuit current release  $(5-6-7-8-9-10) \times I_n$

Internal accessories

Auxiliary contact unit	AX21	101395
Alarm contact unit	AL21	101396
Early-make auxiliary contact	EC 23	106317
Shunt trip releases	SHT24	103723-103730
Undervoltage releases	UVT24	103722-103740

Max. number of installed internal accessories is 4 pcs of AX21, 1 pc of AL21 or EC 23 and 1 pc of a release (SHT24 or UVT24)

External accessories

Direct rotary handle	RHD24	103742
Extended rotary handle	ERH24	103741
Remote motor operators	MOD24	103743-103747
Terminal cover, short	TCV24 3P, 4P	103748, 103750
Terminal cover, long	TCE24 3P, 4P	103749, 104855
Phase barrier set	PB24 3P, 4P	103751, 104856
Connection terminals	MC24	106314

Mounting screws as well as phase barriers in the scope of delivery

### Electrical parameters

	Ex9M4S	Ex9M4N	Ex9M4H	Ex9M4P
Tested according to	IEC/EN 60947-2			
Rated op. voltage $U_e$	415/690 V AC			
Rated insulation voltage $U_i$	800 V			
Rated impulse withstand voltage $U_{imp}$	8 kV			
Rated frequency	50/60 Hz			
Rated ultimate short-circuit breaking capacity $I_{cu}$	36 kA / 415 V 10 kA / 690 V	50 kA / 415 V 10 kA / 690 V	100 kA / 415 V 12 kA / 690 V	150 kA / 415 V 15 kA / 690 V
Rated service short-circuit breaking capacity $I_{cs}$	36 kA / 415 V 5 kA / 690 V	50 kA / 415 V 5 kA / 690 V	100 kA / 415 V 6 kA / 690 V	150 kA / 415 V 7.5 kA / 690 V
Rated short-circuit making capacity $I_{cm}$	75.6 kA / 415 V 17 kA / 690 V	105 kA / 415 V 17 kA / 690 V	220 kA / 415 V 24 kA / 690 V	330 kA / 415 V 30 kA / 690 V
Rated current	400 — 630 A			
Overvoltage category	III			
Utilization category	A			
Mechanical service life	10 000 operation cycles			
Electrical service life	2 000 operation cycles			
Maximum frequency of switch. cycles	60 cycles per hour			
Total disconnection time at short circuit	< 2 ms			
Internal resistance per pole at 630 A	0.08 mΩ			
Power loss per pole at 630 A	31.8 W			
Line voltage connection	arbitrary above or below			

# Technical Data Ex9M4

## Moulded Case Circuit Breakers up to 630 A

### Mechanical parameters

Device width 3P / 4P	196 / 260 mm
Device height	300 mm
Device depth	142 mm
Mounting	onto panel
Degree of protection	IP40, IP20 terminals
Terminals	M12 screws
Busbar thickness	≤ 10 mm
Busbar width	≤ 50 mm
Cable lug width	≤ 50 mm
Fastening torque of terminals	25 — 30 Nm
Ambient temperature	-25 — +70 °C
Altitude	≤ 2 000 m
Relative humidity	≤ 50 % at 40 °C, ≤ 90 % monthly average
Resistance to humidity and heat	class 2
Pollution degree	3
Weight 3P / 4P	10.2 kg / 13.5 kg
Mounting position	vertical, can be rotated by 90° in each axis

### Wiring diagram

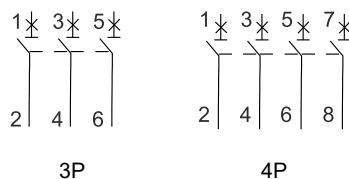

### Dimensions

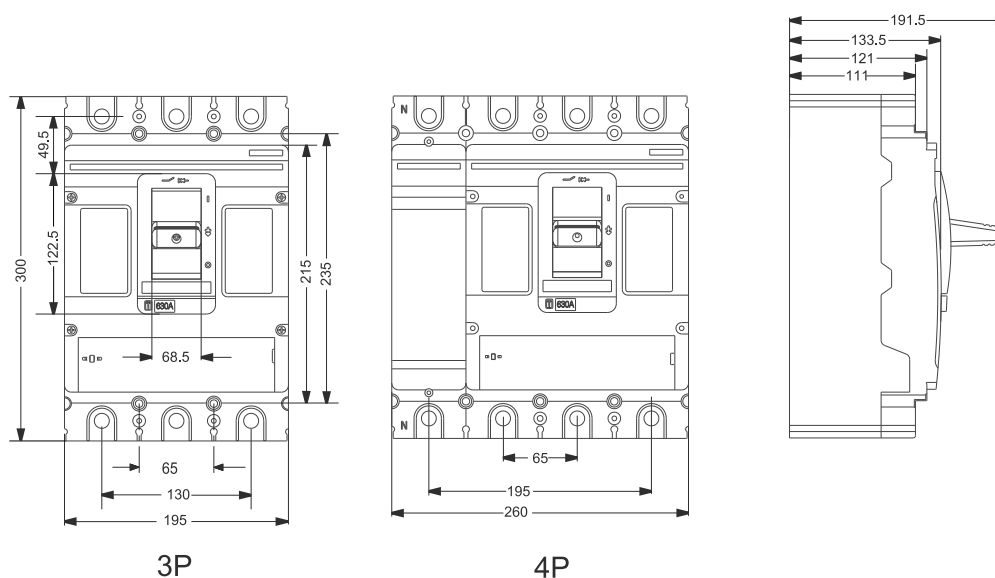

# Technical Data Ex9M4

## Moulded Case Circuit Breakers up to 630 A

### Installation space

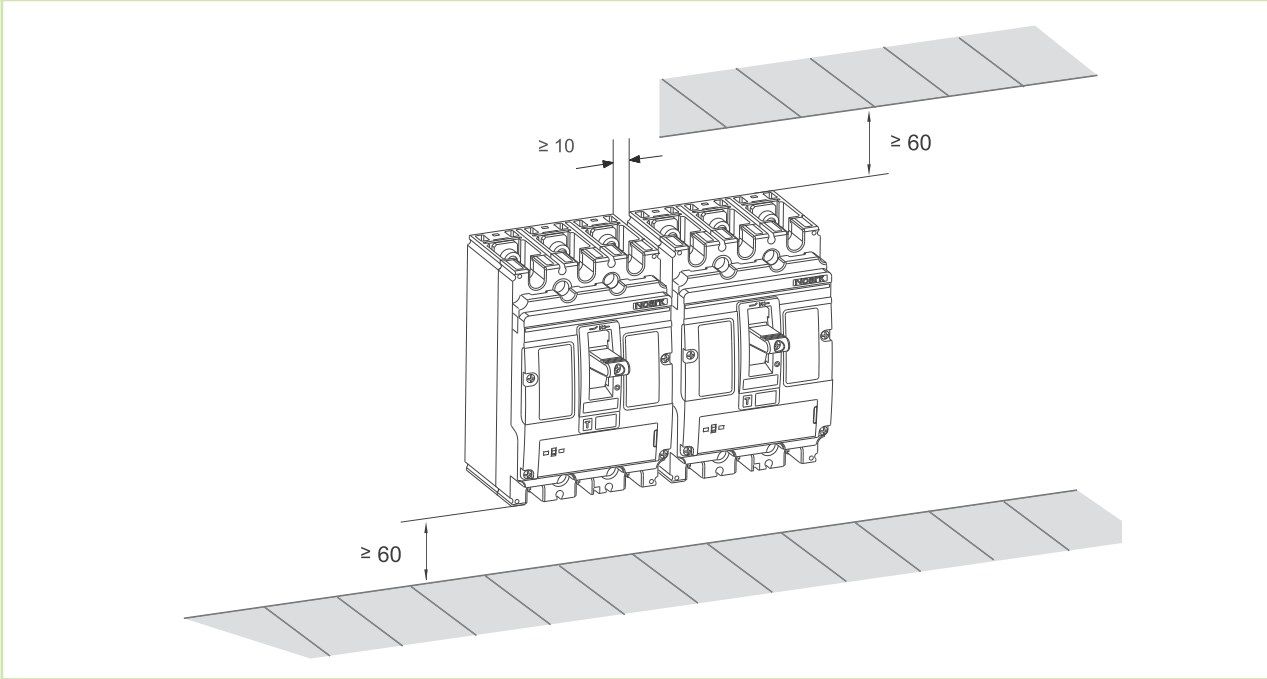

### Tripping characteristics

## Ex9M4

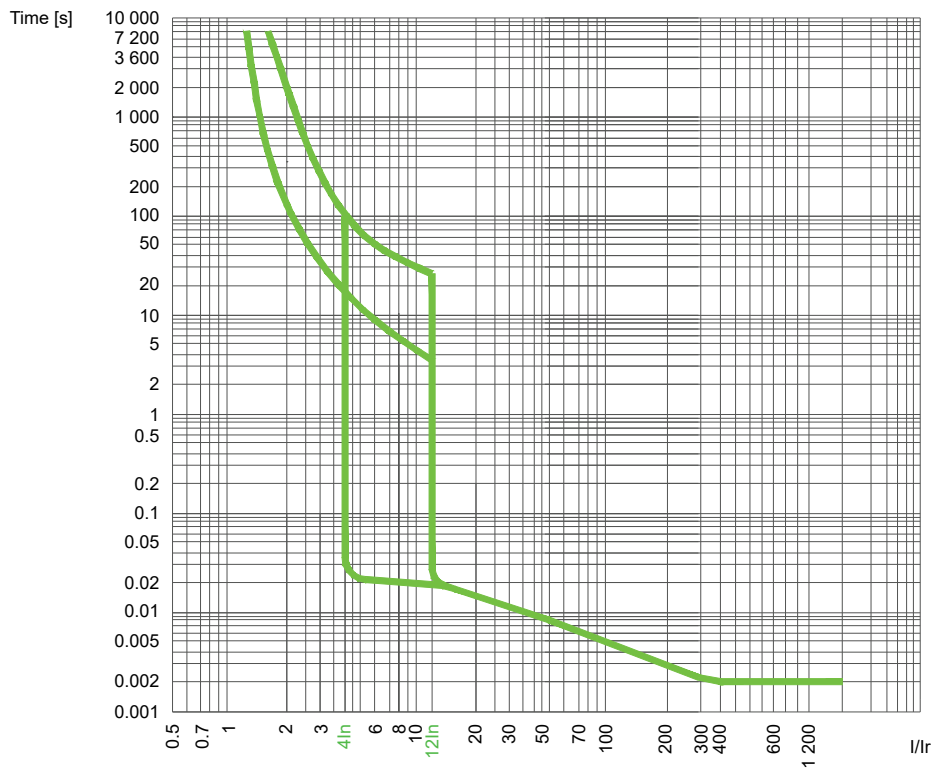



# Technical Data Ex9M5

## Moulded Case Circuit Breakers up to 800 A

### General parameters

Suitable for industrial applications

Thermal release adjustable  $(0.8-0.9-1) \times I_n$

Instantaneous short-circuit current release  $(5-6-7-8-9-10) \times I_n$

Internal accessories

Auxiliary contact unit	AX21	101395
Alarm contact unit	AL21	101396
Early-make auxiliary contact	EC 23	106317
Shunt trip releases	SHT24	103723-103730
Undervoltage releases	UVT24	103722-103740

Max. number of installed internal accessories is 4 pcs of AX21, 1 pc of AL21 or EC 23 and 1 pc of a release (SHT24 or UVT24)

External accessories

Direct rotary handle	RHD24	103742
Extended rotary handle	ERH24	103741
Remote motor operators	MOD24	103743-103747
Terminal cover, short	TCV24 3P, 4P	103748, 103750
Terminal cover, long	TCE24 3P, 4P	103749, 104855
Phase barrier set	PB24 3P, 4P	103751, 104856
Connection terminals	MC24	106314

Mounting screws as well as phase barriers in the scope of delivery

### Electrical parameters

	Ex9M5S	Ex9M5N	Ex9M5H	Ex9M5P
Tested according to	IEC/EN 60947-2			
Rated op. voltage $U_e$	415/690 V AC			
Rated insulation voltage $U_i$	800 V			
Rated impulse withstand voltage $U_{imp}$	8 kV			
Rated frequency	50/60 Hz			
Rated ultimate short-circuit breaking capacity $I_{cu}$	36 kA / 415 V 10 kA / 690 V	50 kA / 415 V 10 kA / 690 V	100 kA / 415 V 12 kA / 690 V	150 kA / 415 V 15 kA / 690 V
Rated service short-circuit breaking capacity $I_{cs}$	36 kA / 415 V 5 kA / 690 V	50 kA / 415 V 5 kA / 690 V	100 kA / 415 V 6 kA / 690 V	150 kA / 415 V 7.5 kA / 690 V
Rated short-circuit making capacity $I_{cm}$	75.6 kA / 415 V 17 kA / 690 V	105 kA / 415 V 17 kA / 690 V	220 kA / 415 V 24 kA / 690 V	330 kA / 415 V 30 kA / 690 V
Rated current	630 — 800 A			
Overvoltage category	III			
Utilization category	A			
Mechanical service life	10 000 operation cycles			
Electrical service life	2 000 operation cycles			
Maximum frequency of switch. cycles	60 cycles per hour			
Total disconnection time at short circuit	< 2 ms			
Internal resistance per pole at 800 A	0.08 mΩ			
Power loss per pole at 800 A	51.2 W			
Line voltage connection	arbitrary above or below			

# Technical Data Ex9M5

## Moulded Case Circuit Breakers up to 800 A

### Mechanical parameters

Device width 3P / 4P	196 / 260 mm
Device height	300 mm
Device depth	142 mm
Mounting	onto panel
Degree of protection	IP40, IP20 terminals
Terminals	M12 screws
Busbar thickness	≤ 10 mm
Busbar width	≤ 50 mm
Cable lug width	≤ 50 mm
Fastening torque of terminals	25 — 30 Nm
Ambient temperature	-25 — +70 °C
Altitude	≤ 2 000 m
Relative humidity	≤ 50 % at 40 °C, ≤ 90 % monthly average
Resistance to humidity and heat	class 2
Pollution degree	3
Weight 3P / 4P	10.2 kg / 13.5 kg
Mounting position	vertical, can be rotated by 90° in each axis

### Wiring diagram

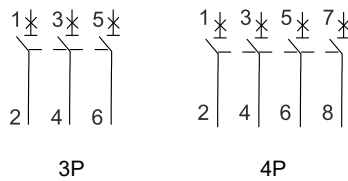

### Dimensions

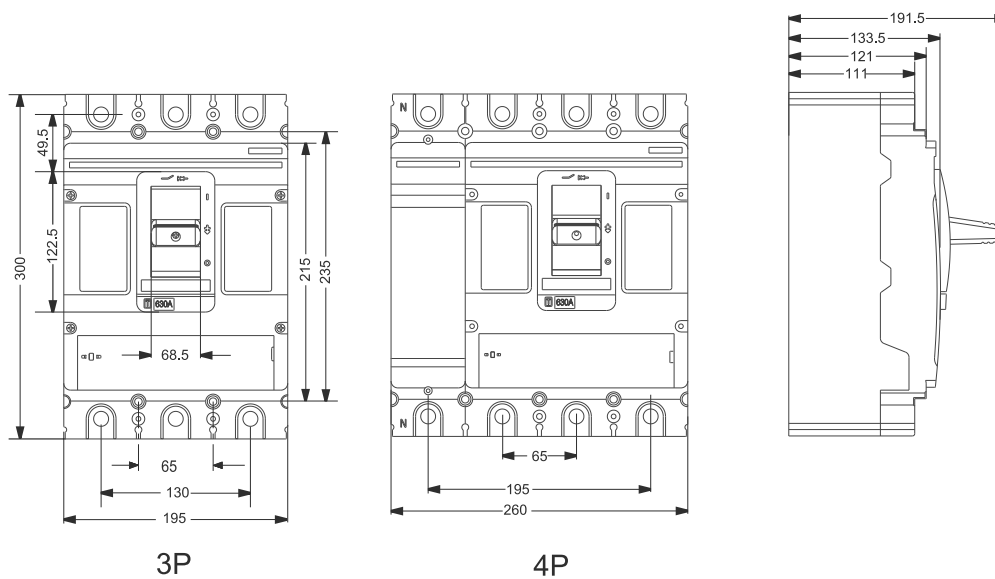

# Technical Data Ex9M5

## Moulded Case Circuit Breakers up to 800 A

### Installation space

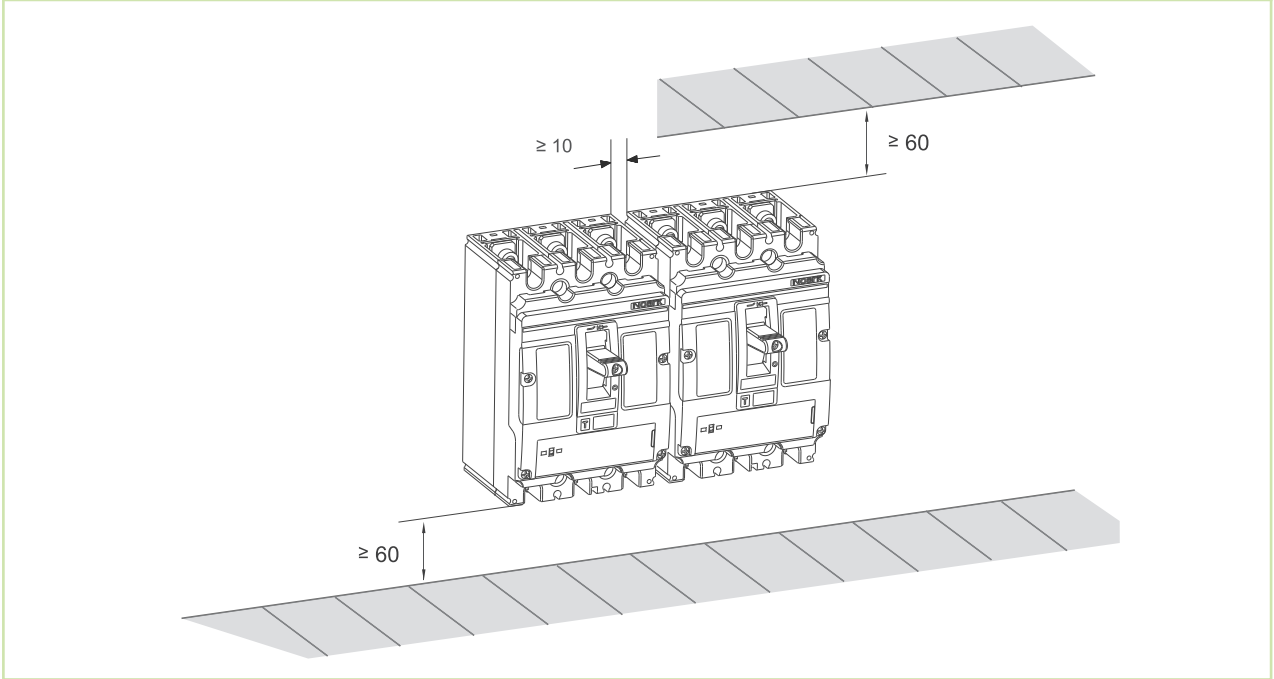

### Tripping characteristics

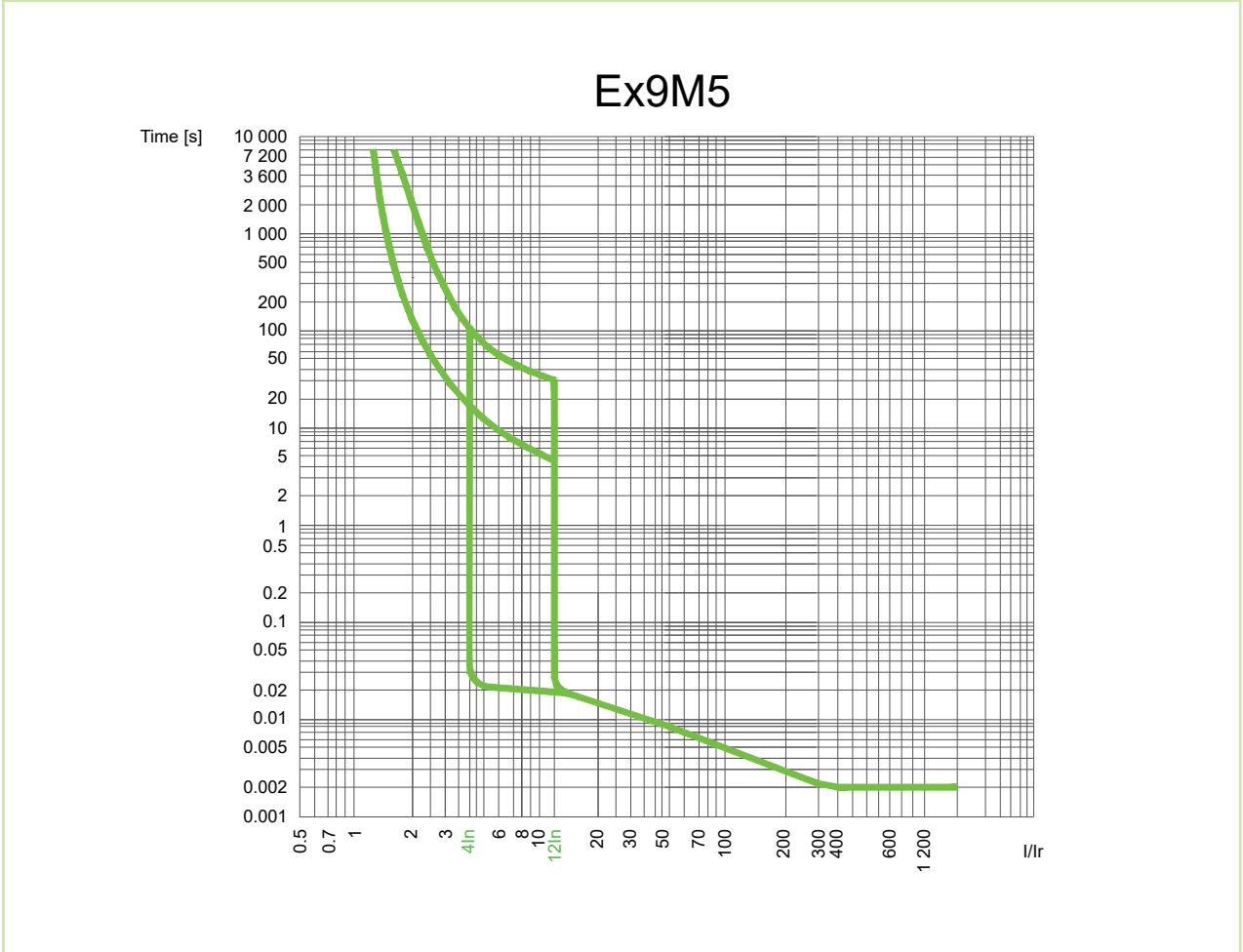

# Technical Data Ex9M6

## Electronic Moulded Case Circuit Breakers up to 1600 A

### General parameters

Suitable for household as well as industrial applications

Thermal release adjustable  $I_r = (0.4-0.5-0.6-0.7-0.8-0.8-0.9-0.95-1) \times I_n$

Instantaneous short-circuit current release adjustable  $I_i = (2-3-4-6-8-10-12) \times I_n$

Internal accessories

Auxiliary contact unit	AX21	101395
Alarm contact unit	AL21	101396
Shunt trip releases	SHT26	110460 — 110467
Undervoltage releases	UVT26	110468 — 110469

Max. number of installed internal accessories is 2 pcs of AX21, 1 pc of AL21 and 1 pc of a release (SHT26 or UVT26)

External accessories

Extended handle	LHD26	110698
Extended rotary handle	ERH26	110718
Front connection plate	JP26	110694 — 110697

Mounting screws and phase barriers in the scope of delivery

### Electrical parameters

	Ex9M6N	Ex9M6Q	Ex9M6H
Tested according to	IEC/EN 60947-2		
Rated op. voltage $U_e$	415 / 690 V AC		
Rated insulation voltage $U_i$	1000 V		
Rated impulse withstand voltage $U_{imp}$	8 kV		
Rated frequency	50/60 Hz		
Rated ultimate short-circuit breaking capacity $I_{cu}$	50 kA / 415 V 30 kA / 690 V	70 kA / 415 V 30 kA / 690 V	100 kA / 415 V 30 kA / 690 V
Rated service short-circuit breaking capacity $I_{cs}$	50 kA / 415 V 30 kA / 690 V	70 kA / 415 V 30 kA / 690 V	70 kA / 415 V 30 kA / 690 V
Rated short-circuit making capacity $I_{cm}$	105 kA / 415 V 63 kA / 690 V	154 kA / 415 V 63 kA / 690 V	220 kA / 415 V 63 kA / 690 V
Rated short time (1s) withstand current $I_{ow}$	20 kA		
Rated current	800 — 1600 A		
Overvoltage category	III		
Utilization category	B		
Mechanical service life	6 000 operation cycles		
Electrical service life	1 000 operation cycles		
Recommended frequency of switch. cycles	20 operating cycles per hour		
Maximum frequency of switch. cycles	60 operating cycles per hour		
Total disconnection time at short circuit	< 10 ms		
Internal resistance per pole at 1600 A	0.05 mΩ		
Power loss per pole at 1600 A	128 W		
Line voltage connection	line voltage on top, load on bottom		

# Technical Data Ex9M6

## Electronic Moulded Case Circuit Breakers up to 1600 A

### Mechanical parameters

Device width 3P / 4P	210 mm / 280 mm
Device height	286 mm
Device depth	191 (198) mm
Mounting	onto panel
Degree of protection	IP20
Terminals	M10 screws
Bushbar width	≤ 50 mm
Fastening torque of terminals	25 — 30 Nm
Operating temperature	-25 — +70 °C
Altitude	≤ 2 000 m
Relative humidity	≤ 50 % at 40 °C, ≤ 90 % monthly average
Pollution degree	3
Weight 3P / 4P	13.5 / 17.5 kg
Mounting position	vertical, can be rotated by 90° in each axis

### Wiring diagram

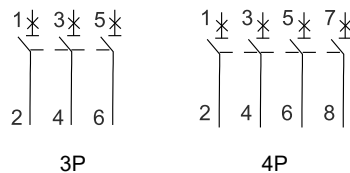

### Dimensions

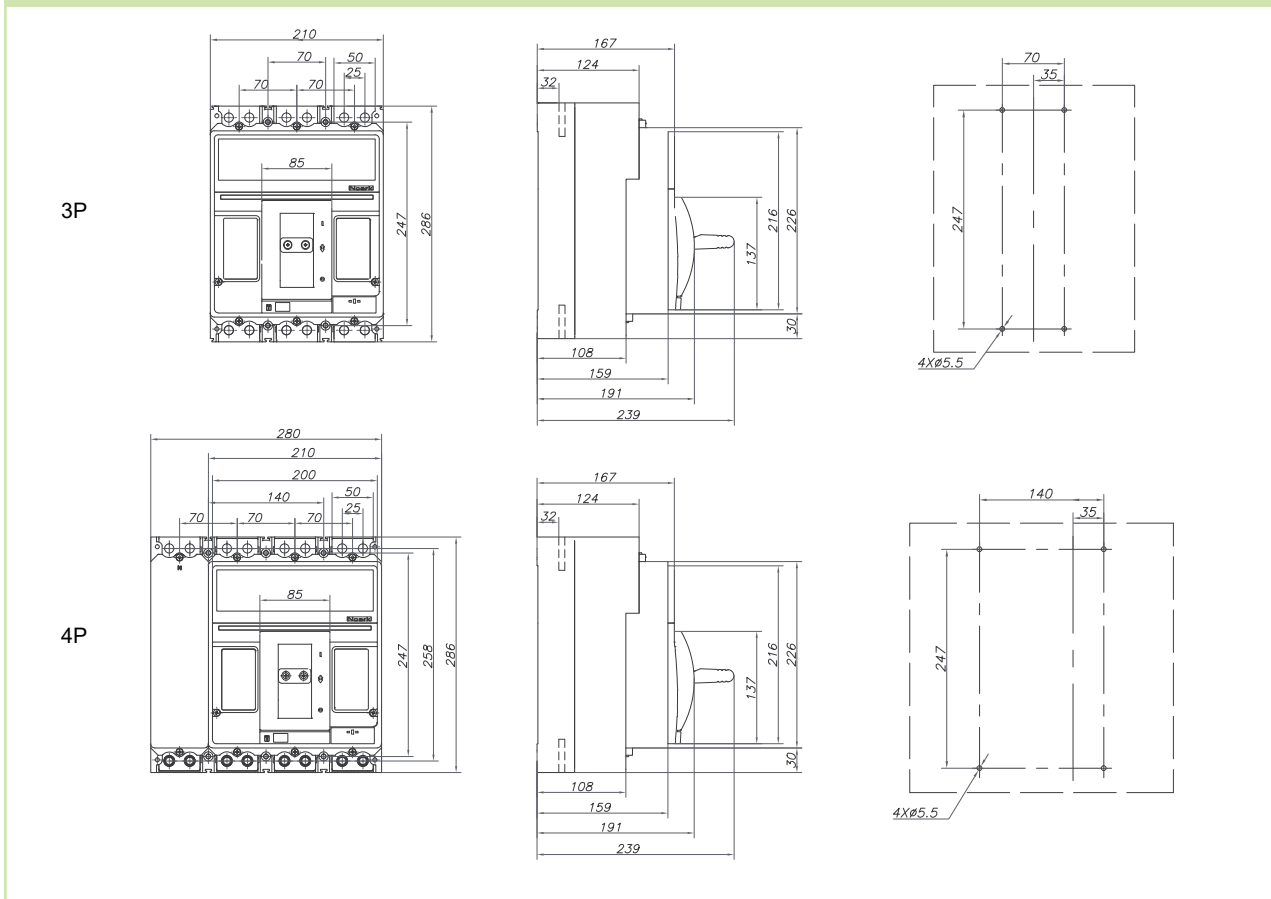

Ordering information p. 22

# Technical Data Ex9M6

## Electronic Moulded Case Circuit Breakers up to 1600 A

### Installation space

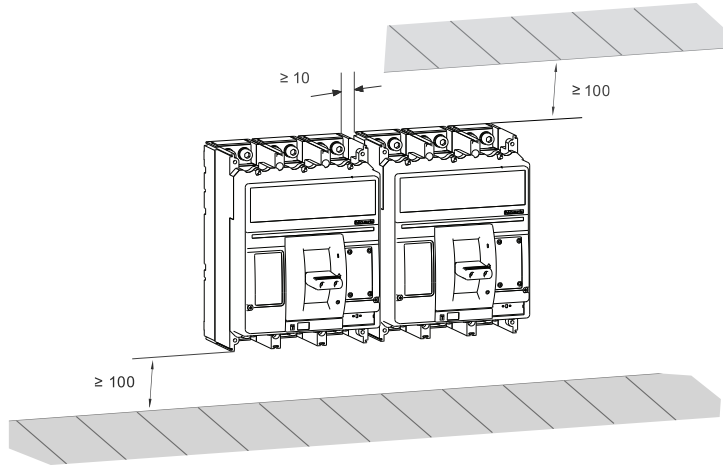

### Tripping characteristics

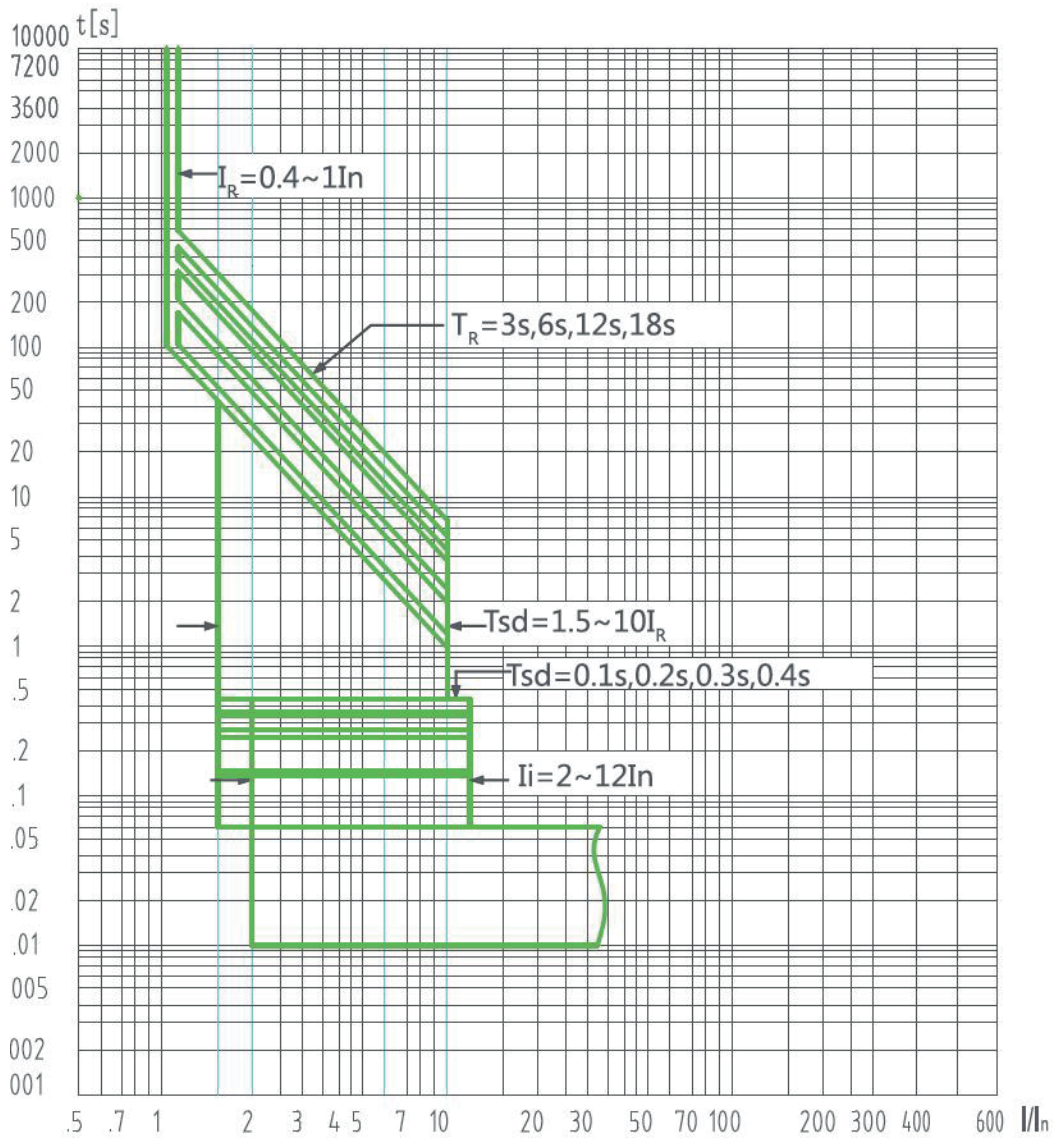

Ordering information p. 22

# Technical Data Ex9M6

## Electronic Moulded Case Circuit Breakers up to 1600 A

### Control panel

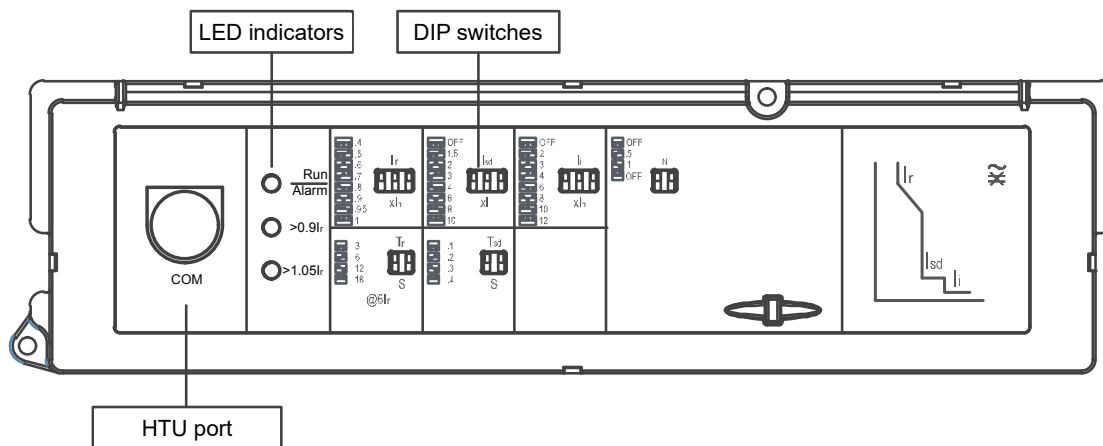

For configuring the operation panel please check the manual of the Electronic tripping unit. The manual can be found at: [www.noark-electric.eu](http://www.noark-electric.eu)

# Technical Data Ex9M6 MOD

## Motor operated electronic MCCBs up to 1600 A

### General parameters

Suitable for household as well as industrial applications

Thermal release adjustable  $I_r = (0.4-0.5-0.6-0.7-0.8-0.8-0.9-0.95-1) \times I_n$

Instantaneous short-circuit current release adjustable  $I_i = (2-3-4-6-8-10-12) \times I_n$

Internal accessories

Auxiliary contact unit	AX21	101395
Alarm contact unit	AL21	101396
Shunt trip releases	SHT26	110460-110467
Undervoltage releases	UVT26	110468-110469

Max. number of installed internal accessories is 2 pcs of AX21, 1 pc of AL21, 1 piece of XF26 and 1 pc of a release (SHT26 or UVT26)

2x AX, 1x AL, 1x SHT26, 1x XF26 with same operative voltage are pre-mounted (customizable under request)

External accessories

Front connection panel	JP26	110694-110697
------------------------	------	---------------

Mounting screws and phase barriers in the scope of delivery

### Electrical parameters

	Ex9M6N	Ex9M6Q	Ex9M6H
Tested according to	IEC/EN 60947-2		
Rated op. voltage $U_e$	415 / 690 V AC		
Rated insulation voltage $U_i$	1000 V		
Rated impulse withstand voltage $U_{imp}$	8 kV		
Rated frequency	50/60 Hz		
Rated ultimate short-circuit breaking capacity $I_{cu}$	50 kA / 415 V 30 kA / 690 V	70 kA / 415 V 30 kA / 690 V	100 kA / 415 V 30 kA / 690 V
Rated service short-circuit breaking capacity $I_{cs}$	50 kA / 415 V 30 kA / 690 V	70 kA / 415 V 30 kA / 690 V	70 kA / 415 V 30 kA / 690 V
Rated short-circuit making capacity $I_{cm}$	105 kA / 415 V 63 kA / 690 V	154 kA / 415 V 63 kA / 690 V	220 kA / 415 V 63 kA / 690 V
Rated short time (1s) withstand current $I_{ow}$	20 kA		
Rated current	800 — 1600 A		
Overvoltage category	III		
Utilization category	B		
Mechanical service life	6 000 operation cycles		
Electrical service life	1 000 operation cycles		
Recommended frequency of switch. cycles	20 operating cycles per hour		
Maximum frequency of switch. cycles	60 operating cycles per hour		
Total disconnection time at short circuit	< 10 ms		
Internal resistance per pole at 1600 A	0.05 mΩ		
Power loss per pole at 1600 A	128 W		
Line voltage connection	line voltage on top, load on bottom		



# Technical Data Ex9M6 MOD

## Motor operated electronic MCCBs up to 1600 A

### Mechanical parameters

Device width 3P / 4P	210 mm / 280 mm
Device height	286 mm
Device depth	198 mm
Mounting	onto panel
Degree of protection	IP20
Terminals	M10 screws
Bushbar width	≤ 50 mm
Fastening torque of terminals	25 — 30 Nm
Operating temperature	-25 — +70 °C
Altitude	≤ 2 000 m
Relative humidity	≤ 50 % at 40 °C, ≤ 90 % monthly average
Pollution degree	3
Weight 3P / 4P	16 / 20 kg
Mounting position	vertical, can be rotated by 90° in each axis

### Wiring diagram

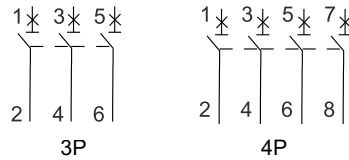

### Dimensions

3P

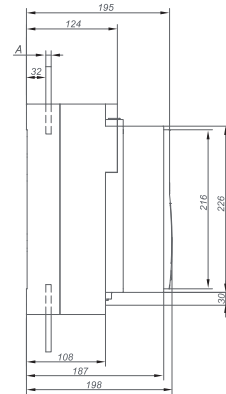
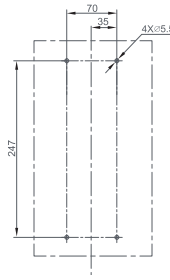
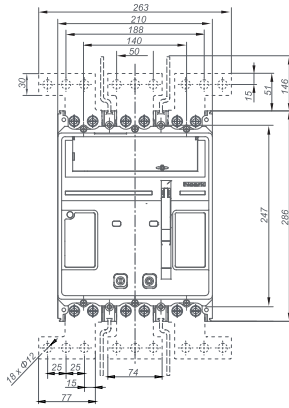

4P

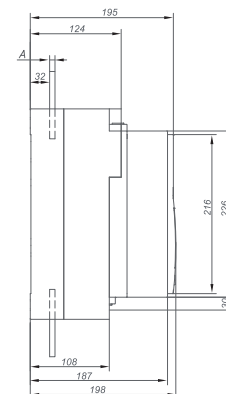
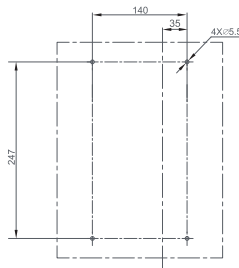
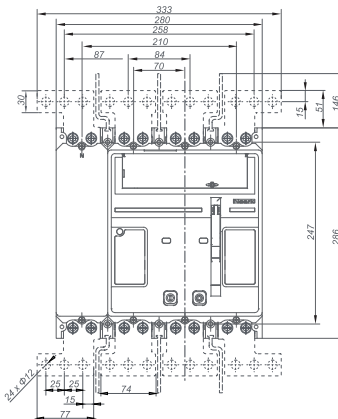

In [A]	800, 1000, 1250	1600
A [mm]	10	20

# Technical Data Ex9M6 MOD

Motor operated electronic MCCBs up to 1600 A

## Installation space

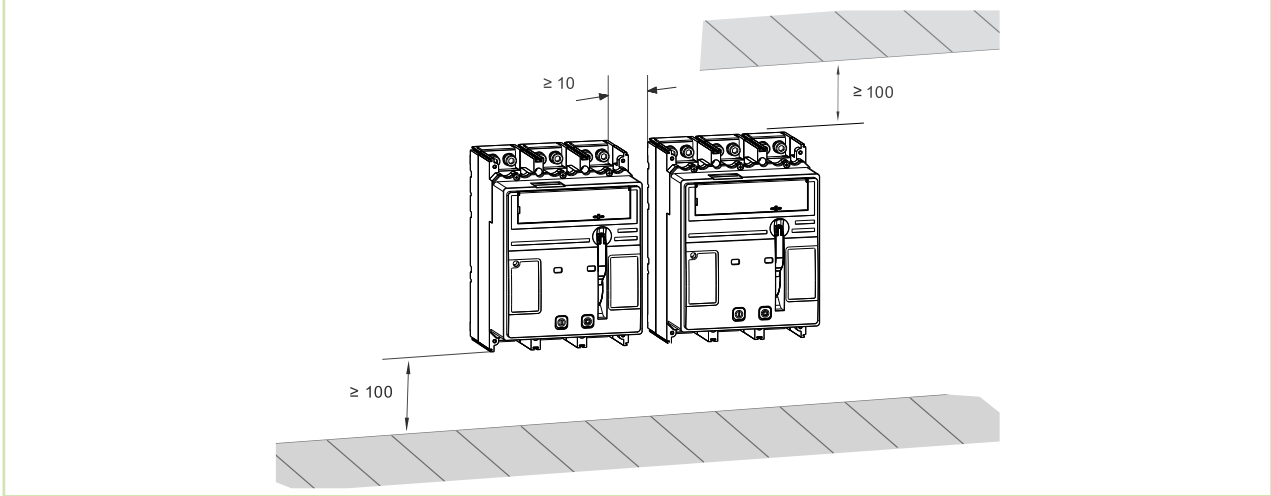

## Tripping characteristics

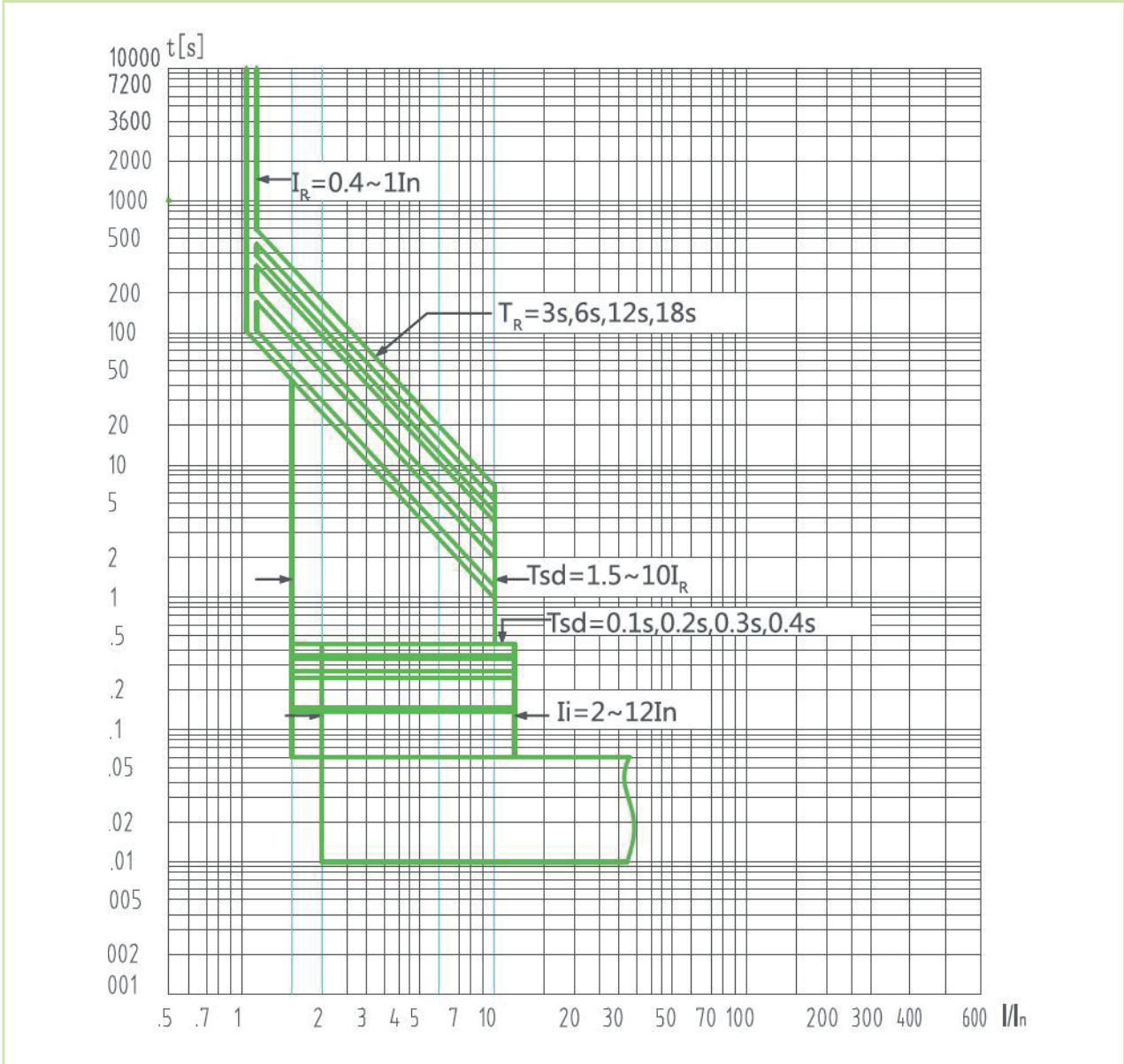

Ordering information p. 26

# Technical Data Ex9M6 MOD

Motor operated electronic MCCBs up to 1600 A

## Control panel

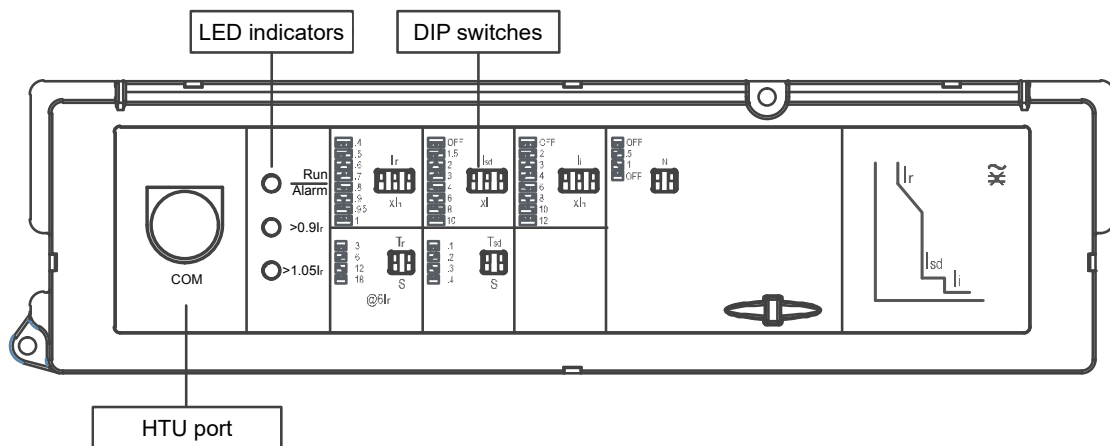

For configuring the operation panel please check the manual of the Electronic tripping unit.  
The manual can be found at: [www.noark-electric.eu](http://www.noark-electric.eu)

# Technical Data Ex9M6 MOD

## Motor operated electronic MCCBs up to 1600 A

### Remote motor operator MOD (MOD version only)

#### General parameters

The electric motor charges the spring mechanism when the circuit breaker is closed

The electric motor MOD is equipped with a limit switch which signals the "charged" position of the mechanism (spring is charged)

The spring-mechanism charging handle can be used when maintaining or without power supply

#### Electrical parameters

Operating voltage $U_e$	230 V AC 400 V AC 110 V DC 220 V DC
Operating frequency	1 operating cycle in 3 minutes
Operating threshold	85 - 110% $U_e$
Power consumption AC DC	40 VA 40 W
Charging time	$\leq 4$ s
Insulation voltage	400 V
Peak current	$6 \times I_n$

# Technical Data Ex9M6 MOD

## Motor operated electronic MCCBs up to 1600 A

### Closing releases XF (MOD version only)

#### General parameters

Remotely close the breaker after the spring has stored energy

Operating voltage range 85 - 110% of nominal value  $U_e$ . Maximum allowed control command length 2 s (can be blocked e.g. by means of NC auxiliary contact, see below)

#### Electrical parameters

Operating voltage $U_e$	230 V AC 400 V AC 110 V DC 220 V DC
Operating threshold	85 - 110% $U_e$
Minimum duration of control impuls	0.2 s
Max. allowed duration of control impuls	2 s
Pick-up power time 100ms AC DC	200 VA 200 W
Power consumption AC DC	5 VA 5 W
Circuit breaker closing time	$\leq 50$ ms
Breaking time	$30 \pm 10$ ms
Insulation voltage	400 V
Peak current	$6 \times I_n$

#### Connection diagram for long control signals

In case external control circuit cannot assure not-exceeding of max. impuls duration, AX contact of NC configuration can be used for limiting (direct connection with XF 230 or 400 V AC, signal to advanced control system in case of use of SHT for DC control voltages due to maximum allowed current of AX).

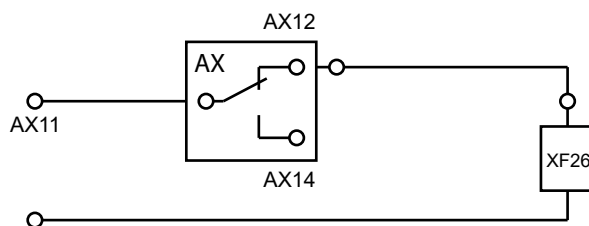

# Technical Data Ex9M1SD

## AC MCCB Switch Disconnectors up to 125 A

### General parameters

Suitable mainly for industrial applications

#### Internal accessories

Auxiliary contact unit	AX21	101395
Early-make auxiliary contact	EC 21	106315
Shunt trip releases	SHT21	101397-101405
Undervoltage releases	UVT21	101406-101407

Max. number of installed internal accessories is 2 pcs of AX21, 1 pc of EC 21 and 1 pc of a release (SHT21 or UVT21)

#### External accessories

Direct rotary handle	RHD21	101410
Extended rotary handle	ERH21	101409
Remote motor operators	MOD21	101411-101415
Terminal cover, short	TCV21 3P, TCV21 4P	101439, 102372
Terminal cover, long	TCE21 3P, TCE21 4P	101440, 102373
Phase barrier set	PB21 3P, 4P	101441, 104852
Connection terminals	MC21	103705-103708
DIN-rail adaptor	DRA21	106319

Mounting screws, box terminals as well as phase barriers in the scope of delivery

### Electrical parameters

Tested according to	IEC/EN 60947-3
Rated operating voltage $U_e$	415 / 690 V AC
Rated insulation voltage $U_i$	800 V AC
Rated impulse withstand voltage $U_{imp}$	8 kV
Rated current $I_n$	63 — 125 A
Rated short time withstand current $I_{cw}$	
1 s	1 800 A
3 s	1 800 A
Rated short time making capacity $I_{cm}$	3 kA
Overvoltage category	III
Utilization category	A
Mechanical service life	15 000 operation cycles
Electrical service life	5 000 operation cycles
Maximum frequency of switch. cycles	120 cycles per hour

# Technical Data Ex9M1SD

## AC MCCB Switch Disconnectors up to 125 A

### Mechanical parameters

Device width (3P / 4P)	90 mm / 120 mm
Device height	140 mm
Device depth	81.6 mm
Mounting	onto panel
Degree of protection	IP40, IP20 terminals
Terminals	box
Terminal capacity	4 — 95 mm <sup>2</sup>
Fastening torque of terminals	8 Nm
Ambient temperature	-25 — +70 °C
Altitude	≤ 2 000 m
Relative humidity	≤ 50 % at 40 °C, ≤ 90 % monthly average
Resistance to humidity and heat	class 2
Pollution degree	3
Weight (3P / 4P)	1.0 kg / 1.5 kg
Mounting position	vertical, can be rotated by 90° in each axis

### Wiring diagram

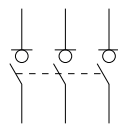

3P

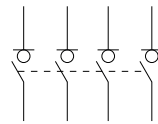

4P

# Technical Data Ex9M1SD

## AC MCCB Switch Disconnectors up to 125 A

### Dimensions

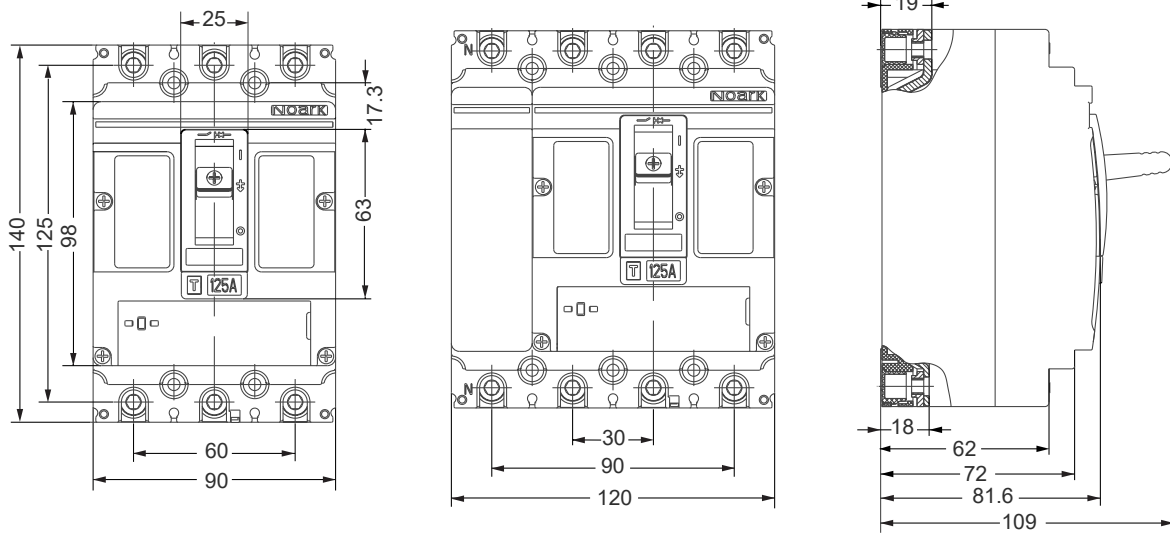

### Installation space

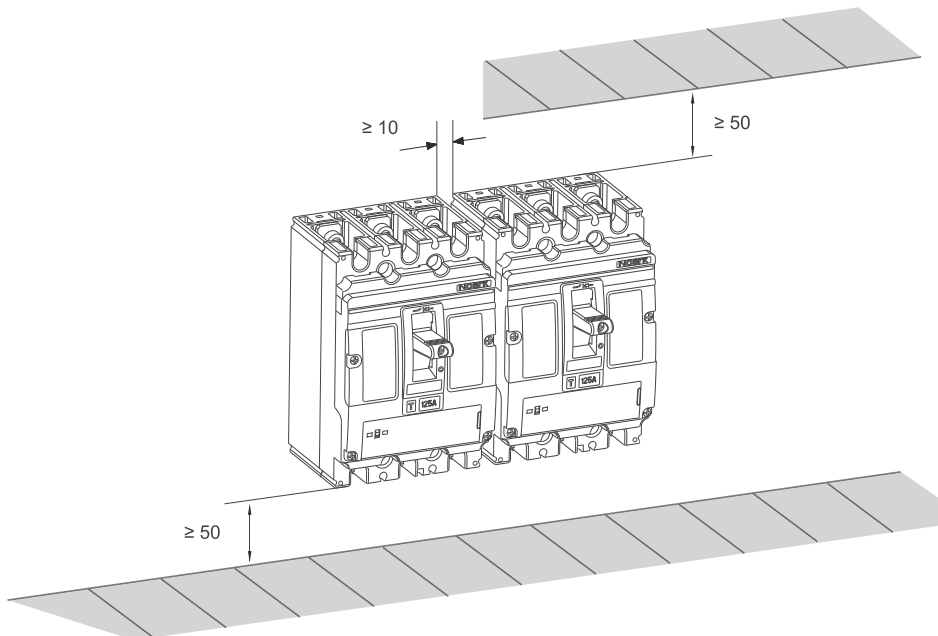



# Technical Data Ex9M2SD

## AC MCCB Switch Disconnectors up to 250 A

### General parameters

Suitable mainly for industrial applications		
Internal accessories		
Auxiliary contact unit	AX21	101395
Early-make auxiliary contact	EC 21	106315
Shunt trip releases	SHT22	101416-101424
Undervoltage releases	UVT22	101425-101426
Max. number of installed internal accessories is 2 pcs of AX21, 1 pc of EC 21 and 1 pc of a release (SHT22 or UVT22)		
External accessories		
Direct rotary handle	RHD22	101429
Extended rotary handle	ERH22	101428
Remote motor operators	MOD22	101430-101434
Terminal cover, short	TCV22 3P, TCV22 4P	101442, 102374
Terminal cover, long	TCE22 3P, TCE22 4P	101443, 102375
Phase barrier set	PB22 3P, 4P	101444, 104853
Connection terminals	MC22	103709-103714
DIN-rail adaptor	DRA22	106320
Mounting screws, box terminals as well as phase barriers in the scope of delivery		

### Electrical parameters

Tested according to	IEC/EN 60947-3
Rated operating voltage $U_e$	415 / 690 V AC
Rated insulation voltage $U_i$	800 V AC
Rated impulse withstand voltage $U_{imp}$	8 kV
Rated current $i_n$	125 — 250 A
Rated short time withstand current $I_{cw}$	
1 s	3 200 A
3 s	3 200 A
Rated short time making capacity $I_{cm}$	5 kA
Overvoltage category	III
Utilization category	A
Mechanical service life	15 000 operation cycles
Electrical service life	5 000 operation cycles
Maximum frequency of switch. cycles	120 cycles per hour

# Technical Data Ex9M2SD

## AC MCCB Switch Disconnectors up to 250 A

### Mechanical parameters

Device width (3P / 4P)	105 mm / 140 mm
Device height	157 mm
Device depth	91.5 mm
Mounting	onto panel
Degree of protection	IP40, IP20 terminals
Terminals	box
Terminal capacity	10 — 120 mm <sup>2</sup>
Fastening torque of terminals	25 Nm
Ambient temperature	-25 — +70 °C
Altitude	≤ 2 000 m
Relative humidity	≤ 50 % at 40 °C, ≤ 90 % monthly average
Resistance to humidity and heat	class 2
Pollution degree	3
Weight (3P / 4P)	1.5 / 2.0 kg
Mounting position	vertical, can be rotated by 90° in each axis

### Wiring diagram

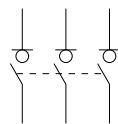

3P

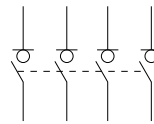

4P

# Technical Data Ex9M2SD

AC MCCB Switch Disconnectors up to 250 A

## Dimensions

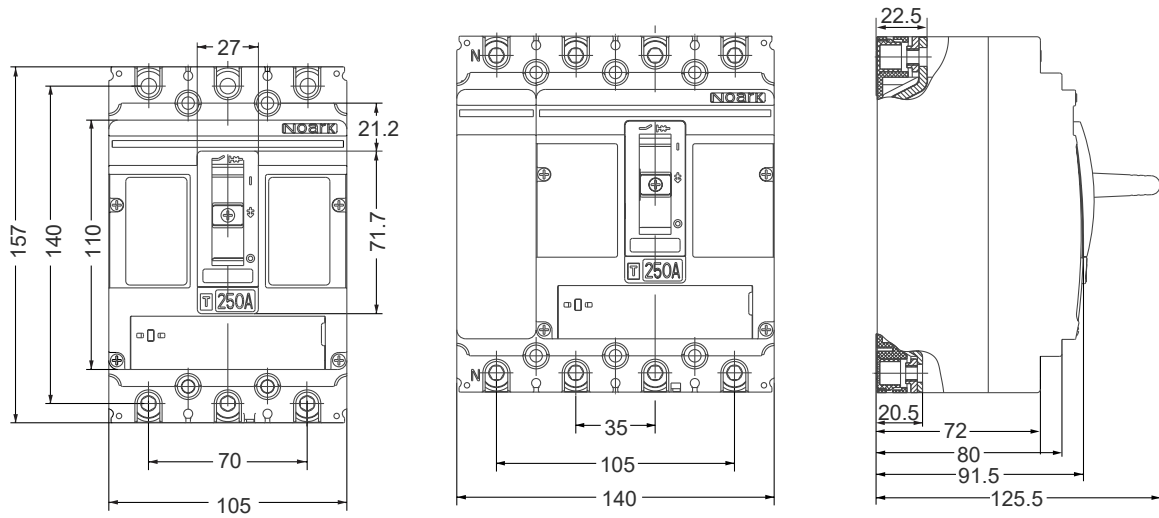

## Installation space

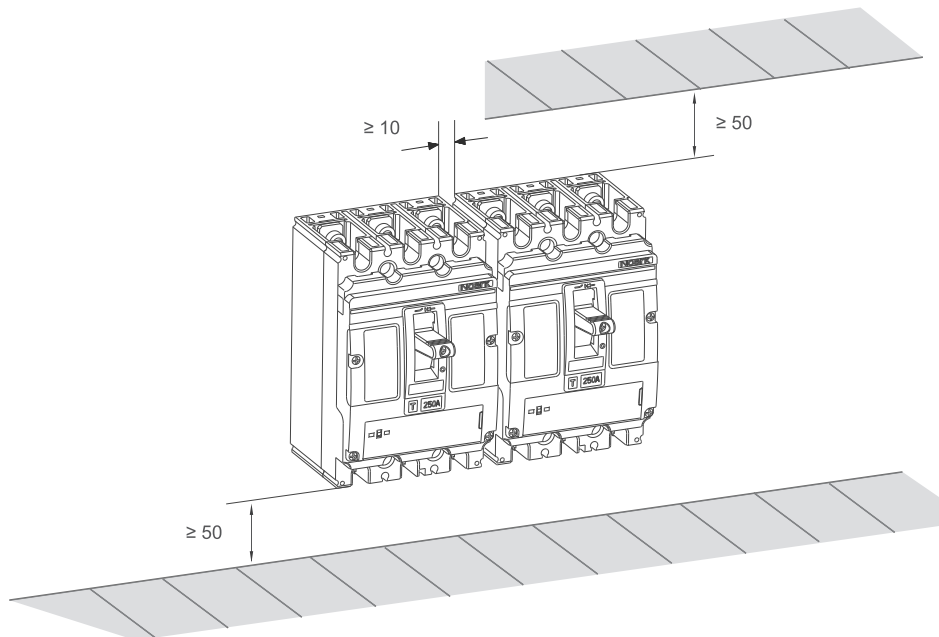

# Technical Data Ex9M3SD

## AC MCCB Switch Disconnectors up to 400 A

### General parameters

Suitable mainly for industrial applications

#### Internal accessories

Auxiliary contact unit	AX21	101395
Early-make auxiliary contact	EC 23	106317
Shunt trip releases	SHT22	101416-101424
Undervoltage releases	UVT22	101425-101426

Max. number of installed internal accessories is 3 pcs of AX21, 1 pc of EC 23 and 1 pc of a release (SHT22 or UVT22)

#### External accessories

Direct rotary handle	RHD23	101483
Extended rotary handle	ERH23	101482
Remote motor operators	MOD23	101484-101488
Terminal cover, short	TCV23 3P, TCV23 4P	101489, 102376
Terminal cover, long	TCE23 3P, TCE23 4P	101490, 102377
Phase barrier set	PB23 3P, 4P	101491, 104854
Connection terminals	MC23	103715-103722

Mounting screws as well as phase barriers in the scope of delivery

### Electrical parameters

Tested according to	IEC/EN 60947-3
Rated operating voltage $U_e$	415 / 690 V AC
Rated insulation voltage $U_i$	800 V AC
Rated impulse withstand voltage $U_{imp}$	8 kV
Rated current $I_n$	250 — 400 A
Rated short time withstand current $I_{cw}$	
1 s	5 000 A
3 s	5 000 A
Rated short time making capacity $I_{cm}$	7.7 kA
Overvoltage category	III
Utilization category	A
Mechanical service life	10 000 operation cycles
Electrical service life	2 000 operation cycles
Maximum frequency of switch. cycles	60 cycles per hour

# Technical Data Ex9M3SD

## AC MCCB Switch Disconnectors up to 400 A

### Mechanical parameters

Device width (3P / 4P)	140 mm / 185 mm
Device height	255 mm
Device depth	118.5 mm
Mounting	onto panel
Degree of protection	IP40, IP20 terminals
Terminals	M10 screws
Busbar thickness	≤ 8 mm
Busbar width	≤ 30 mm
Cable lug width	≤ 30 mm
Fastening torque of terminals	25 — 30 Nm
Ambient temperature	-25 — +70 °C
Altitude	≤ 2 000 m
Relative humidity	≤ 50 % at 40 °C, ≤ 90 % monthly average
Resistance to humidity and heat	class 2
Pollution degree	3
Weight (3P / 4P)	4.5 kg / 6 kg
Mounting position	vertical, can be rotated by 90° in each axis

### Wiring diagram

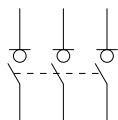

3P

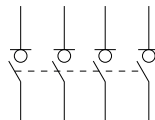

4P

# Technical Data Ex9M3SD

## AC MCCB Switch Disconnectors up to 400 A

### Dimensions

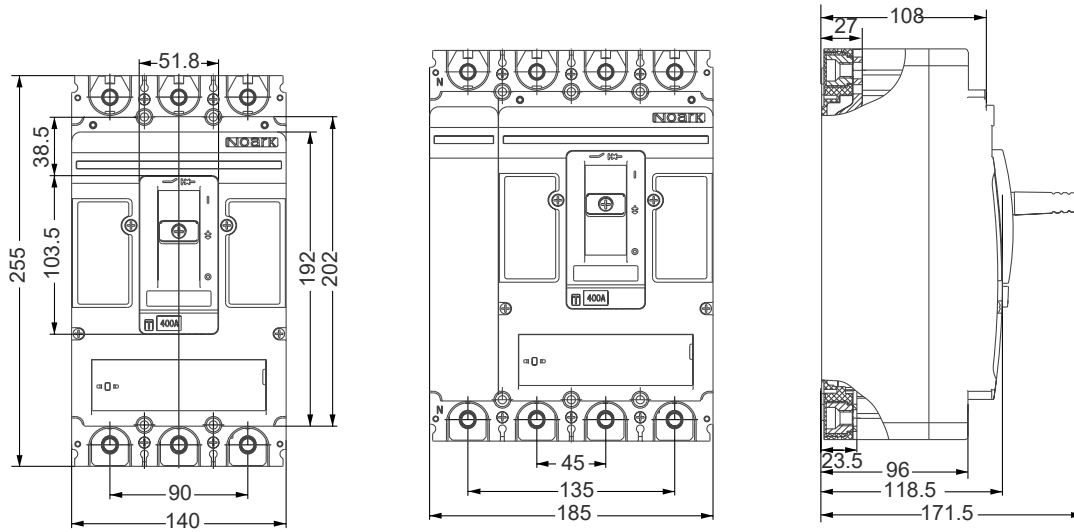

### Installation space

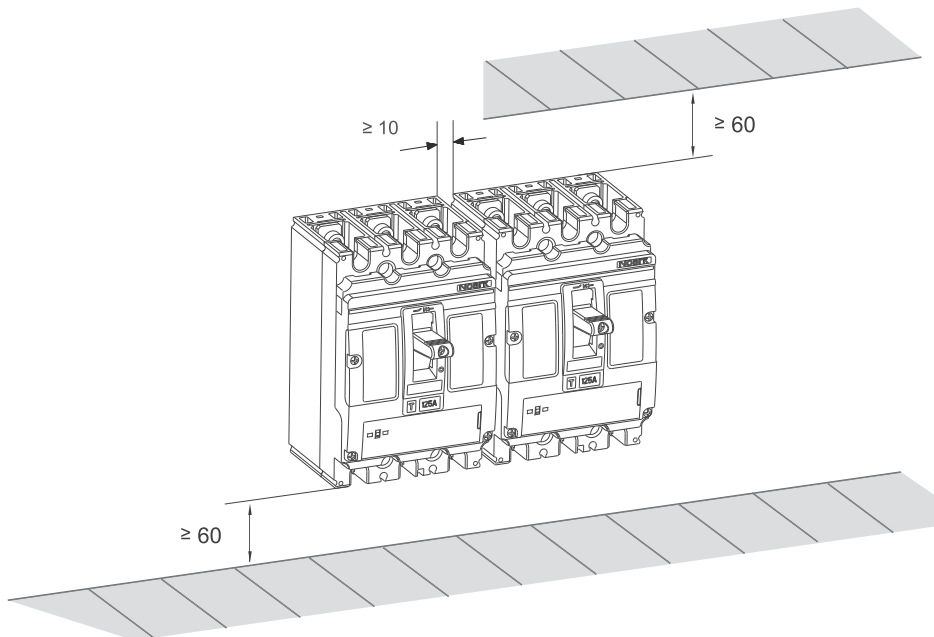

# Technical Data Ex9M4SD

## AC MCCB Switch Disconnectors up to 630 A

### General parameters

Suitable mainly for industrial applications

#### Internal accessories

Auxiliary contact unit	AX21	101395
Early-make auxiliary contact	EC 23	106317
Shunt trip releases	SHT24	103723-103730
Undervoltage releases	UVT24	103733-103740

Max. number of installed internal accessories is 4 pcs of AX21, 1 pc of EC 23 and 1 pc of a release (SHT24 or UVT24)

#### External accessories

Direct rotary handle	RHD24	103742
Extended rotary handle	ERH24	103741
Remote motor operators	MOD24	103743-103747
Terminal cover, short	TCV24 3P, 4P	103748, 103750
Terminal cover, long	TCE24 3P, 4P	103749, 104855
Phase barrier set	PB24 3P, 4P	103751, 104856
Connection terminals	MC24	106314

Mounting screws as well as phase barriers in the scope of delivery

### Electrical parameters

Tested according to	IEC/EN 60947-3
Rated operating voltage $U_e$	415 / 690 V AC
Rated insulation voltage $U_i$	800 V AC
Rated impulse withstand voltage $U_{imp}$	8 kV
Rated current $I_n$	630 A
Rated short time withstand current $I_{ow}$	
1 s	8 000 A
3 s	8 000 A
Rated short time making capacity $I_{cm}$	14 kA
Overvoltage category	III
Utilization category	A
Mechanical service life	5 000 operation cycles
Electrical service life	2 000 operation cycles
Maximum frequency of switch. cycles	60 cycles per hour

# Technical Data Ex9M4SD

## AC MCCB Switch Disconnectors up to 630 A

### Mechanical parameters

Device width (3P / 4P)	195 mm / 260 mm
Device height	300 mm
Device depth	142 mm
Mounting	onto panel
Degree of protection	IP40, IP20 terminals
Terminals	M12 screws
Busbar thickness	≤ 10 mm
Busbar width	≤ 50 mm
Cable lug width	≤ 50 mm
Fastening torque of terminals	25 — 30 Nm
Ambient temperature	-25 — +70 °C
Altitude	≤ 2 000 m
Relative humidity	≤ 50 % at 40 °C, ≤ 90 % monthly average
Resistance to humidity and heat	class 2
Pollution degree	3
Weight (3P / 4P)	9.5 kg / 12.7 kg
Mounting position	vertical, can be rotated by 90° in each axis

### Wiring diagram

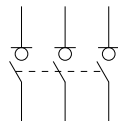

3P

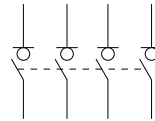

4P



# Technical Data Ex9M4SD

AC MCCB Switch Disconnectors up to 630 A

## Dimensions

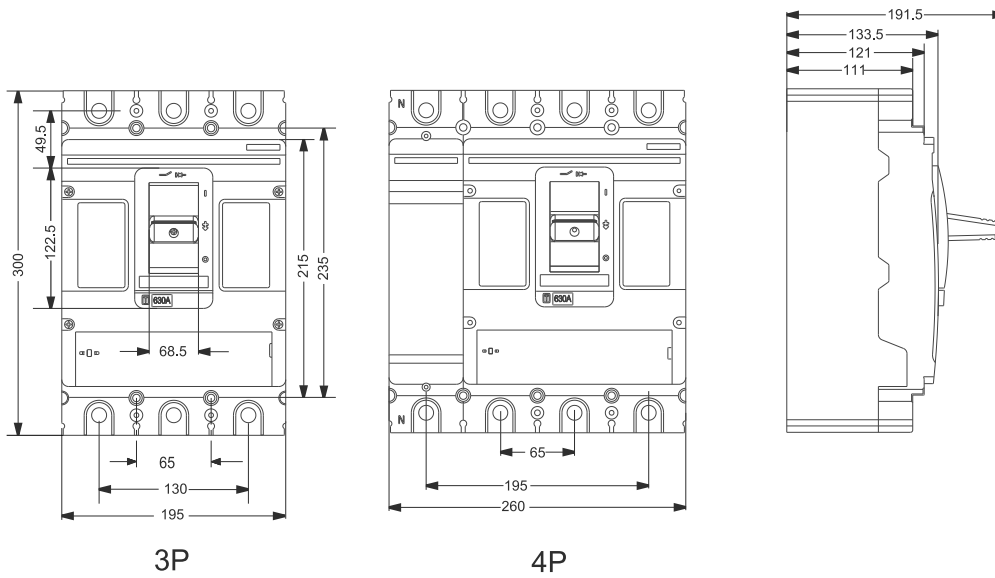

## Installation space

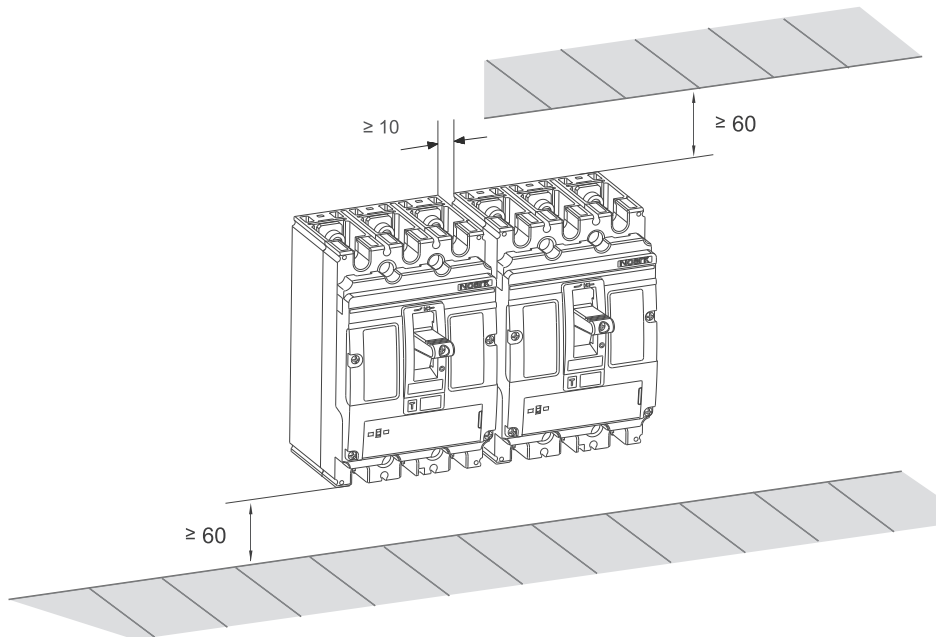

# Technical Data Ex9M5SD

## AC MCCB Switch Disconnectors up to 800 A

### General parameters

Suitable mainly for industrial applications

#### Internal accessories

Auxiliary contact unit	AX21	101395
Early-make auxiliary contact	EC 23	106317
Shunt trip releases	SHT24	103723-103730
Undervoltage releases	UVT24	103733-103740

Max. number of installed internal accessories is 4 pcs of AX21, 1 pc of EC 23 and 1 pc of a release (SHT24 or UVT24)

#### External accessories

Direct rotary handle	RHD24	103742
Extended rotary handle	ERH24	103741
Remote motor operators	MOD24	103743-103747
Terminal cover, short	TCV24 3P, 4P	103748, 103750
Terminal cover, long	TCE24 3P, 4P	103749, 104855
Phase barrier set	PB24 3P, 4P	103751, 104856
Connection terminals	MC24	106314

Mounting screws as well as phase barriers in the scope of delivery

### Electrical parameters

Tested according to	IEC/EN 60947-3
Rated operating voltage $U_e$	415 / 690 V AC
Rated insulation voltage $U_i$	800 V AC
Rated impulse withstand voltage $U_{imp}$	8 kV
Rated current $I_n$	800 A
Rated short time withstand current $I_{cw}$	
1 s	10 000 A
3 s	10 000 A
Rated short time making capacity $I_{cm}$	17 kA
Overvoltage category	III
Utilization category	A
Mechanical service life	5 000 operation cycles
Electrical service life	2 000 operation cycles
Maximum frequency of switch. cycles	60 cycles per hour

# Technical Data Ex9M5SD

## AC MCCB Switch Disconnectors up to 800 A

### Mechanical parameters

Device width (3P / 4P)	195 mm / 260 mm
Device height	300 mm
Device depth	142 mm
Mounting	onto panel
Degree of protection	IP40, IP20 terminals
Terminals	M12 screws
Busbar thickness	≤ 10 mm
Busbar width	≤ 50 mm
Cable lug width	≤ 50 mm
Fastening torque of terminals	25 — 30 Nm
Ambient temperature	-25 — +70 °C
Altitude	≤ 2 000 m
Relative humidity	≤ 50 % at 40 °C, ≤ 90 % monthly average
Resistance to humidity and heat	class 2
Pollution degree	3
Weight (3P / 4P)	9.5 kg / 12.7 kg
Mounting position	vertical, can be rotated by 90° in each axis

### Wiring diagram

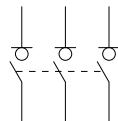

3P

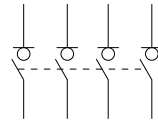

4P

# Technical Data Ex9M5SD

AC MCCB Switch Disconnectors up to 800 A

## Dimensions

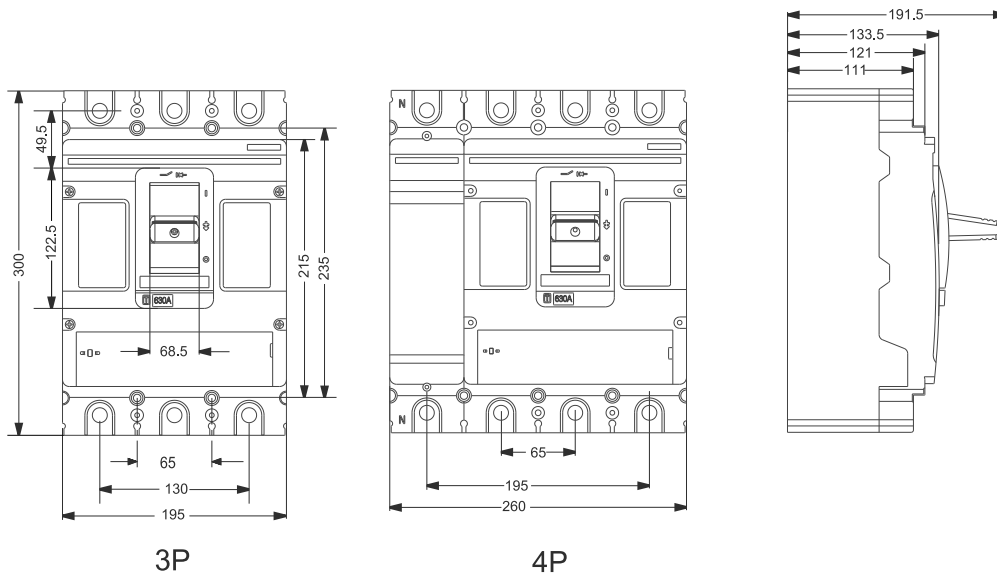

## Installation space

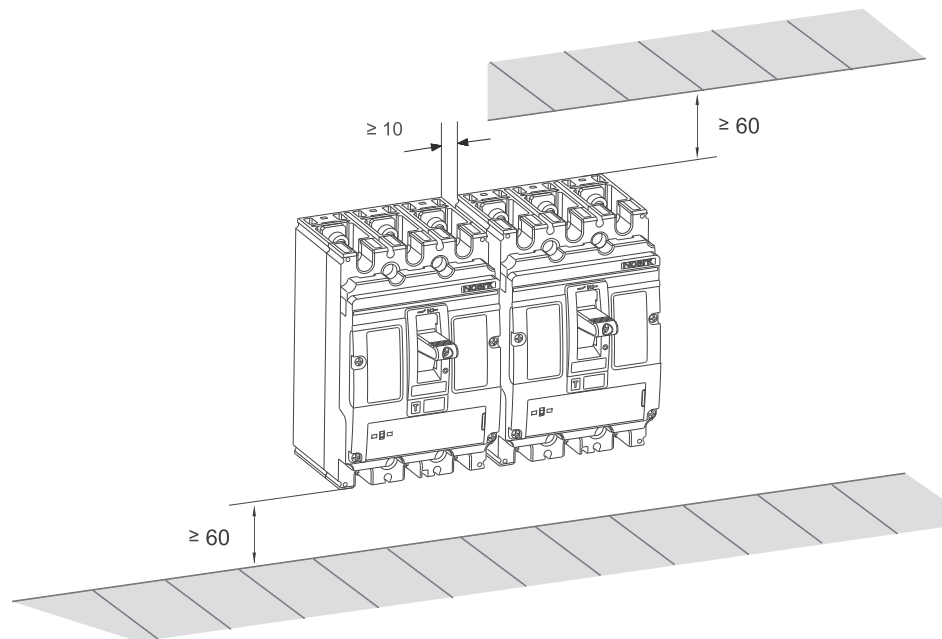

Ordering information p. 36

# Technical Data Ex9M6SD

## Moulded Case Switch Disconnectors up to 1600 A

### General parameters

Suitable for household as well as industrial applications

#### Internal accessories

Auxiliary contact unit	AX21	101395
Shunt trip releases	SHT26	110460 — 110467
Undervoltage releases	UVT26	110468 — 110469

Max. number of installed internal accessories is 2 pcs of AX21 and 1 pc of a release (SHT26 or UVT26)

#### External accessories

Extended handle	LHD26	110698
Extended rotary handle	ERH26	108846
Front connection plate	JP26	110694 — 110697

Mounting screws and phase barriers in the scope of delivery

### Electrical parameters

Tested according to	IEC/EN 60947-3
Rated op. voltage $U_e$	415 / 690 V AC
Rated insulation voltage $U_i$	1500 V
Rated impulse withstand voltage $U_{imp}$	12 kV
Rated frequency	50/60 Hz
Rated current	800 — 1600 A
Overvoltage category	III
Utilization category	AC-22A, AC-23A
Mechanical service life	6 000 operation cycles
Electrical service life	1 000 operation cycles
Maximum frequency of switch. cycles	60 operating cycles per hour
Total disconnection time at short circuit	< 10 ms
Internal resistance per pole at 1600 A	0.05 m $\Omega$
Power loss per pole at 1600 A	128 W
Line voltage connection	line voltage on top, load on bottom

### Wiring diagram

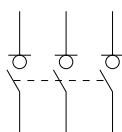

3P

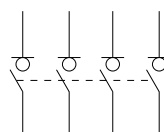

4P

# Technical Data Ex9M6SD

## Moulded Case Switch Disconnectors up to 1600 A

### Mechanical parameters

Device width 3P / 4P	210 mm / 280 mm
Device height	286 mm
Device depth	191 (198) mm
Mounting	onto panel
Degree of protection	IP20
Terminals	M10 screws
Bushbar width	≤ 50 mm
Fastening torque of terminals	25 — 30 Nm
Operating temperature	-40 — +70 °C
Altitude	≤ 2 000 m
Relative humidity	≤ 50 % at 40 °C, ≤ 90 % monthly average
Pollution degree	3
Weight 3P / 4P	13.5 / 17.5 kg
Mounting position	vertical, can be rotated by 90° in each axis

### Dimensions

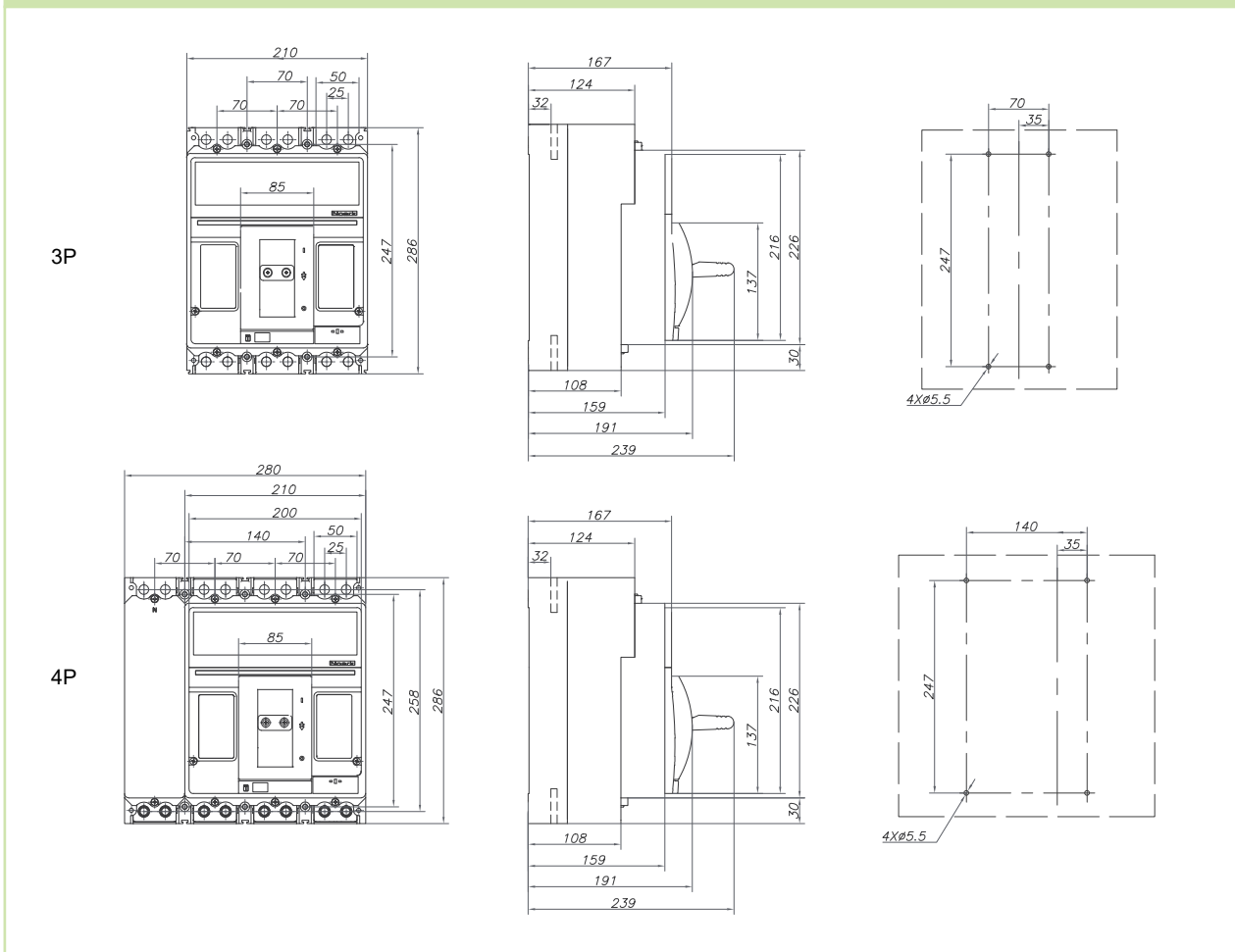

Ordering information p. 40

# Technical Data Ex9M6SD

Moulded Case Switch Disconnectors up to 1600 A

## Installation space

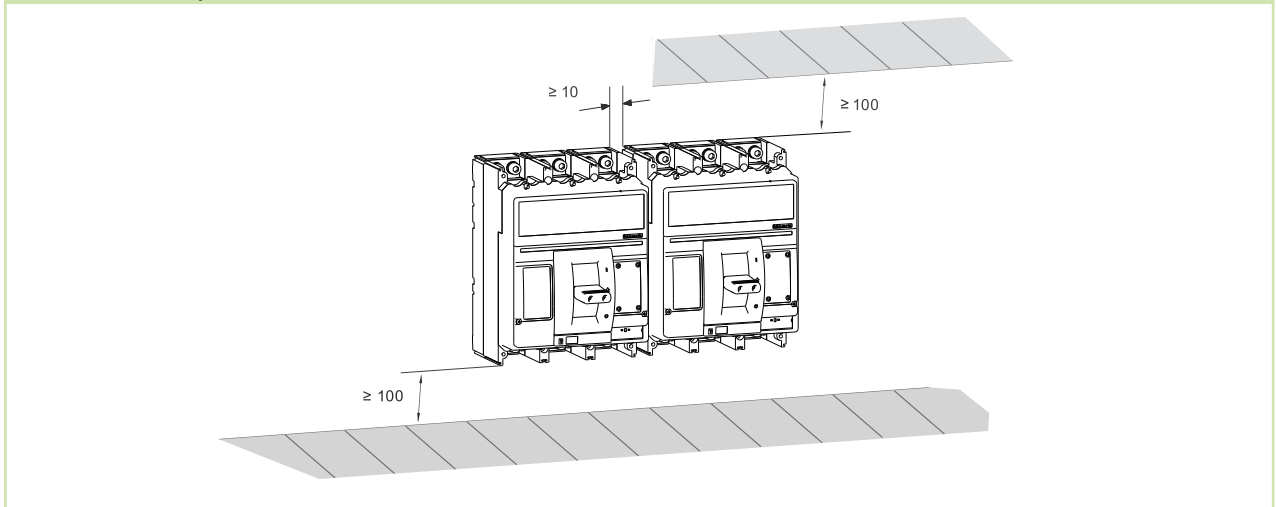

# Technical Data Ex9MD1

## DC Moulded Case Circuit Breakers up to 125 A

### General parameters

Suitable for PV and similar applications		
Thermal release adjustable (0.8-0.9-1) x I <sub>n</sub>		
Instantaneous short-circuit current release fixed 10 x I <sub>n</sub>		
Internal accessories		
Auxiliary contact unit	AX21	101395
Alarm contact unit	AL21	101396
Early-make auxiliary contact	EC 21	106315
Shunt trip releases	SHT21	101397-101405
Undervoltage releases	UVT21	101406-101407
Max. number of installed internal accessories is 2 pcs of AX21, 1 pc of AL21 or EC 21 and 1 pc of a release (SHT21 or UVT21)		
External accessories		
Direct rotary handle	RHD21	101410
Extended rotary handle	ERH21	101409
Remote motor operators	MOD21	101411-101415
Terminal cover, short	TCV21 3P, TCV21 4P	101439, 102372
Terminal cover, long	TCE21 3P, TCE21 4P	101440, 102373
Phase barrier set	PB21 3P, PB21 4P	101441, 102398
Connection terminals	MC21	103705-103708
DIN-rail adaptor	DRA21	106319
Mounting screws, interconnection busbars as well as phase barriers in the scope of delivery		

### Electrical parameters

	Ex9MD1B	Ex9MD1S	Ex9MD1N	Ex9MD1H
Tested according to	IEC/EN 60947-2			
Rated op. voltage U <sub>e</sub>	750 (3P), 1000 V DC (4P)			
Rated insulation voltage U <sub>i</sub>	1000 V			
Rated impulse withstand voltage U <sub>imp</sub>	8 kV			
Rated ultimate short-circuit breaking capacity I <sub>cu</sub>	25 kA / 1000 V DC	36 kA / 1000 V DC	50 kA / 1000 V DC	100 kA / 1000 V DC
Rated service short-circuit breaking capacity I <sub>cs</sub>	25 kA / 1000 V DC	36 kA / 1000 V DC	50 kA / 1000 V DC	100 kA / 1000 V DC
Rated short-circuit making capacity I <sub>cm</sub>	52.5 kA / 1000 V DC	75.6 kA / 1000 V DC	105 kA / 1000 V DC	220kA / 1000 V DC
Rated current	16 — 125 A			
Overvoltage category	III			
Utilization category	A			
Mechanical service life	15 000 operation cycles			
Electrical service life	5 000 operation cycles			
Maximum frequency of switch. cycles	120 cycles per hour			
Total disconnection time at short circuit	< 2 ms			
Power loss per pole at 125 A	12.5 W			



# Technical Data Ex9MD1

## DC Moulded Case Circuit Breakers up to 125 A

### Mechanical parameters

Device width (3P / 4P)	90 mm / 120 mm
Device height	140 mm
Device depth	81.6 mm
Mounting	onto panel
Degree of protection	IP40, IP20 terminals
Terminals	M6 screws
Busbar thickness	≤ 4 mm
Busbar width	≤ 14.2 mm
Cable lug width	≤ 14.2 mm
Fastening torque of terminals	10 — 15 Nm
Ambient temperature	-25 — +70 °C
Altitude	≤ 2 000 m
Relative humidity	≤ 50 % at 40 °C, ≤ 90 % monthly average
Resistance to humidity and heat	class 2
Pollution degree	3
Weight (3P / 4P)	1.2 kg / 1.7 kg
Mounting position	vertical, can be rotated by 90° in each axis

### Wiring diagram

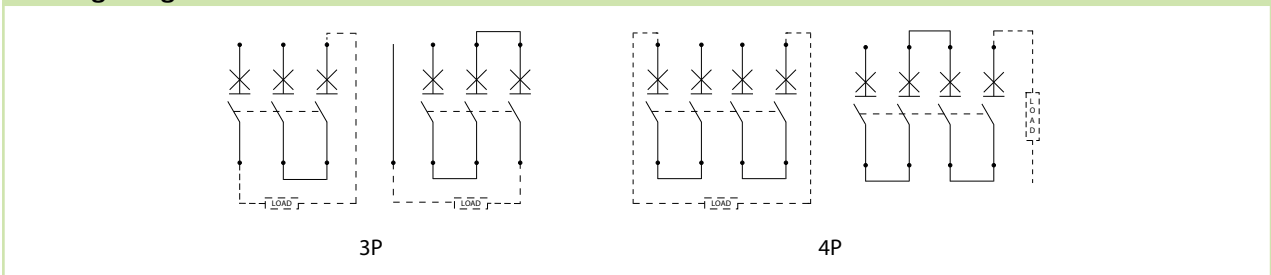

### Dimensions

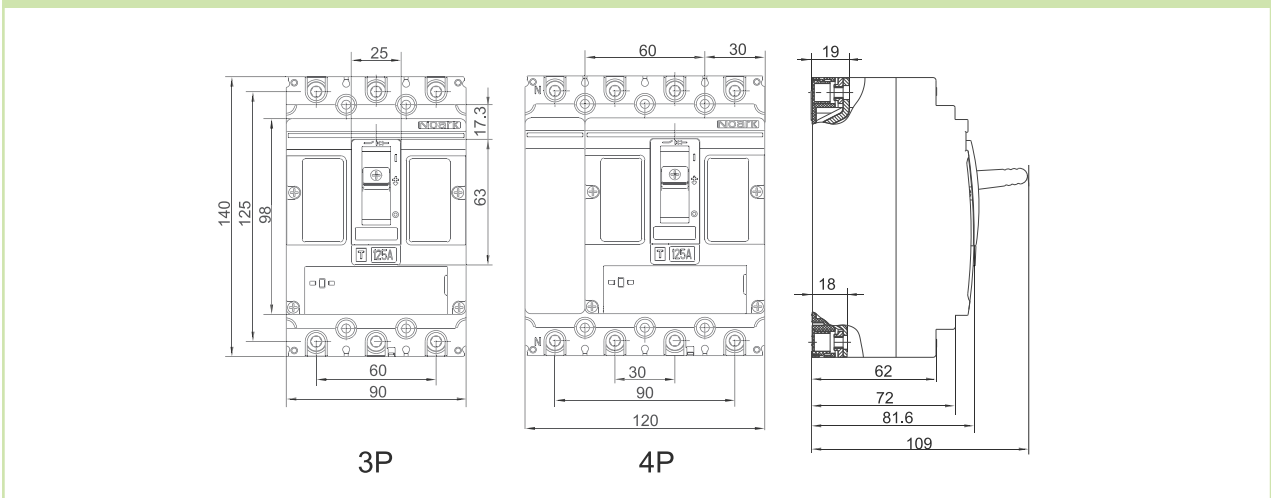

# Technical Data Ex9MD1

## DC Moulded Case Circuit Breakers up to 125 A

### Installation space

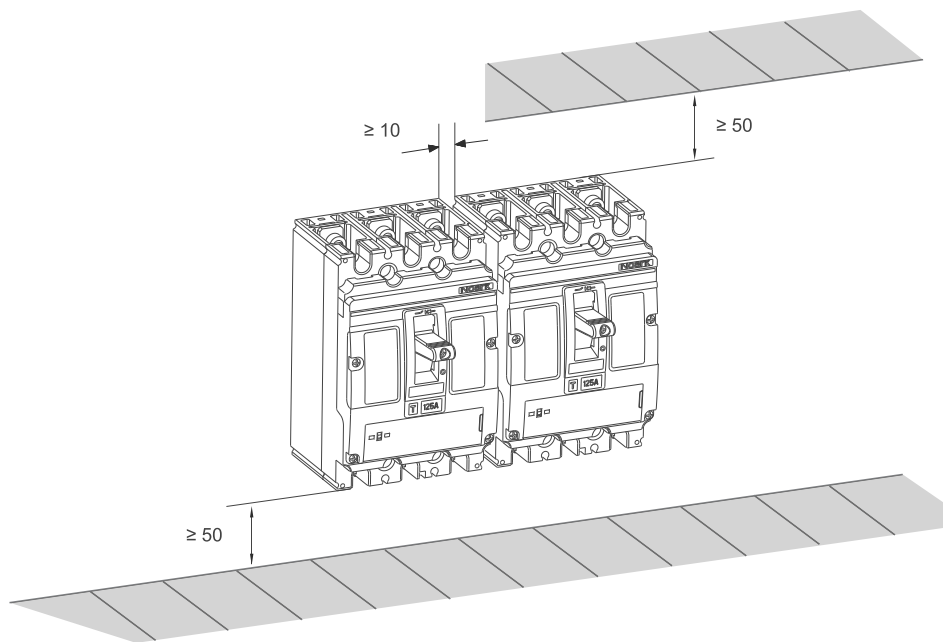

### Tripping characteristic

## Ex9MD1

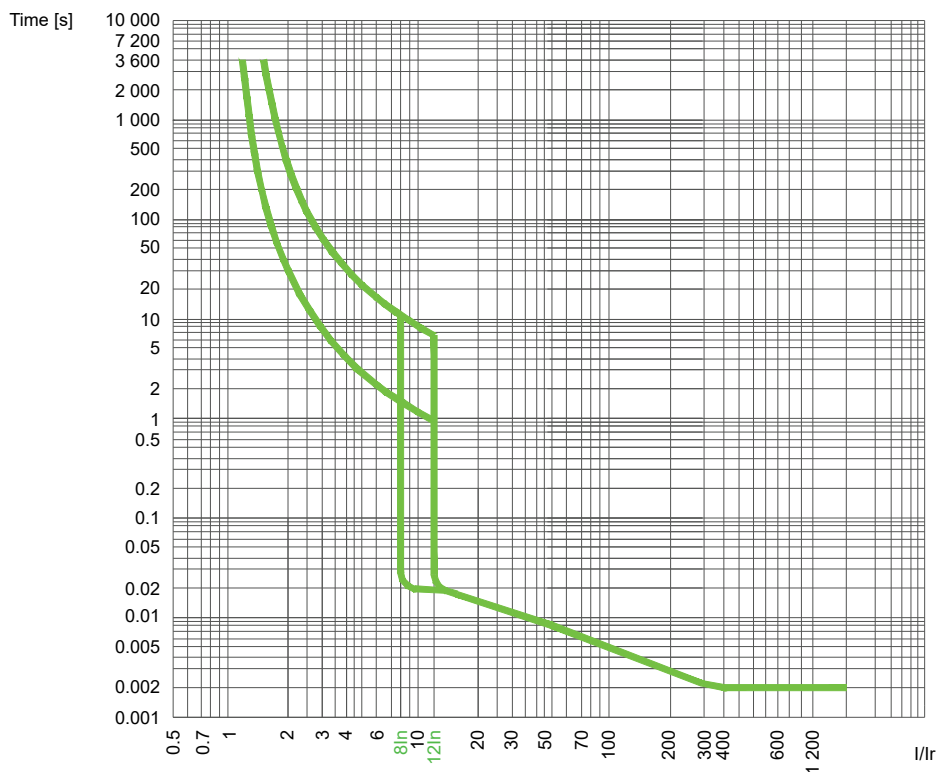

# Technical Data Ex9MD2

## DC Moulded Case Circuit Breakers up to 250 A

### General parameters

Suitable for PV and similar applications

Thermal release adjustable  $(0.8-0.9-1) \times I_n$

Instantaneous short-circuit current release  $(5-6-7-8-9-10) \times I_n$

Internal accessories

Auxiliary contact unit	AX21	101395
Alarm contact unit	AL21	101396
Early-make auxiliary contact	EC 21	106315
Shunt trip releases	SHT22	101416-101424
Undervoltage releases	UVT22	101425-101426

Max. number of installed internal accessories is 2 pcs of AX21, 1 pc of AL21 or EC 21 and 1 pc of a release (SHT22 or UVT22)

External accessories

Direct rotary handle	RHD22	101429
Extended rotary handle	ERH22	101428
Remote motor operators	MOD22	101430-101434
Terminal cover, short	TCV22 3P, TCV22 4P	101442, 102374
Terminal cover, long	TCE22 3P, TCE22 4P	101443, 102375
Phase barrier set	PB22 3P, PB22 4P	101444, 102399
Connection terminals	MC22	103709-103714
DIN-rail adaptor	DRA22	106320

Mounting screws, interconnection busbars as well as phase barriers in the scope of delivery

### Electrical parameters

	Ex9MD2B	Ex9MD2S	Ex9MD2N	Ex9MD2H
Tested according to	IEC/EN 60947-2			
Rated op. voltage $U_e$	750 (3P), 1000 V DC (4P)			
Rated insulation voltage $U_i$	1000 V			
Rated impulse withstand voltage $U_{imp}$	8 kV			
Rated ultimate short-circuit breaking capacity $I_{cu}$	25 kA / 1000 V DC	36 kA / 1000 V DC	50 kA / 1000 V DC	100 kA / 1000 V DC
Rated service short-circuit breaking capacity $I_{cs}$	25 kA / 1000 V DC	36 kA / 1000 V DC	50 kA / 1000 V DC	100 kA / 1000 V DC
Rated short-circuit making capacity $I_{cm}$	52.5 kA / 1000 V DC	75.6 kA / 1000 V DC	105 kA / 1000 V DC	220kA / 1000 V DC
Rated current	125 — 250 A			
Overvoltage category	III			
Utilization category	A			
Mechanical service life	15 000 operation cycles			
Electrical service life	5 000 operation cycles			
Maximum frequency of switch. cycles	120 cycles per hour			
Total disconnection time at short circuit	< 2 ms			
Power loss per pole at 250 A	18.8 W			

# Technical Data Ex9MD2

## DC Moulded Case Circuit Breakers up to 250 A

### Mechanical parameters

Device width (3P / 4P)	105 mm / 140 mm
Device height	157 mm
Device depth	91.5 mm
Mounting	onto panel
Degree of protection	IP40, IP20 terminals
Terminals	M8 screws
Busbar thickness	≤ 6 mm
Busbar width	≤ 25 mm
Cable lug width	≤ 25 mm
Fastening torque of terminals	15 Nm
Ambient temperature	-25 — +70 °C
Altitude	≤ 2 000 m
Relative humidity	≤ 50 % at 40 °C, ≤ 90 % monthly average
Resistance to humidity and heat	class 2
Pollution degree	3
Weight (3P / 4P)	1.7 / 2.2 kg
Mounting position	vertical, can be rotated by 90° in each axis

### Wiring diagram

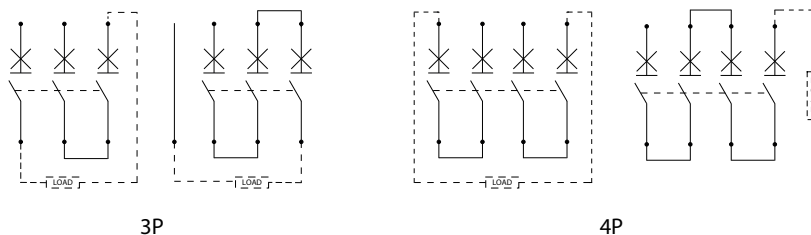

### Dimensions

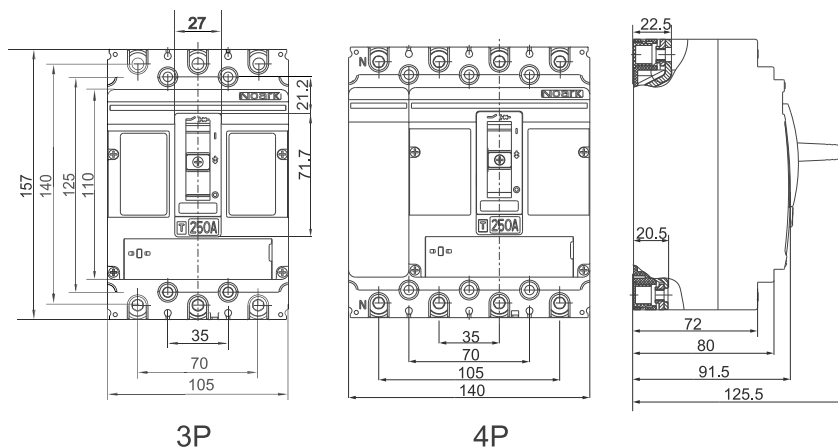

# Technical Data Ex9MD2

## DC Moulded Case Circuit Breakers up to 250 A

### Installation space

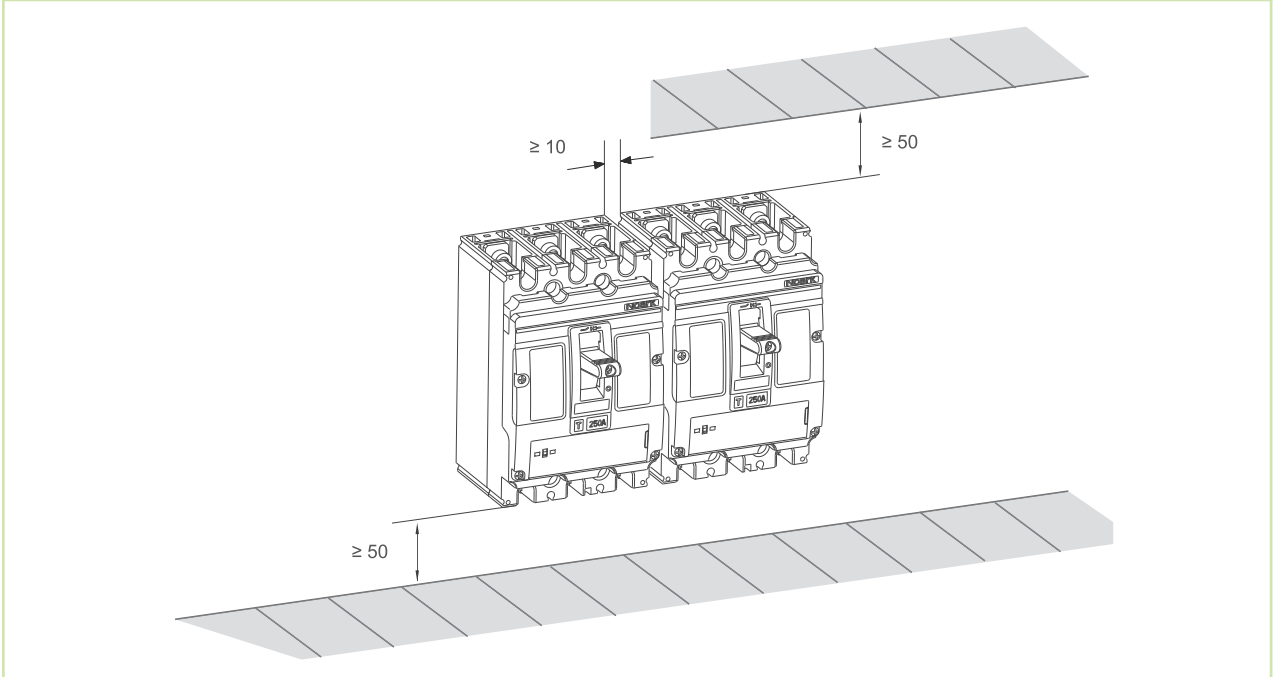

### Tripping characteristic

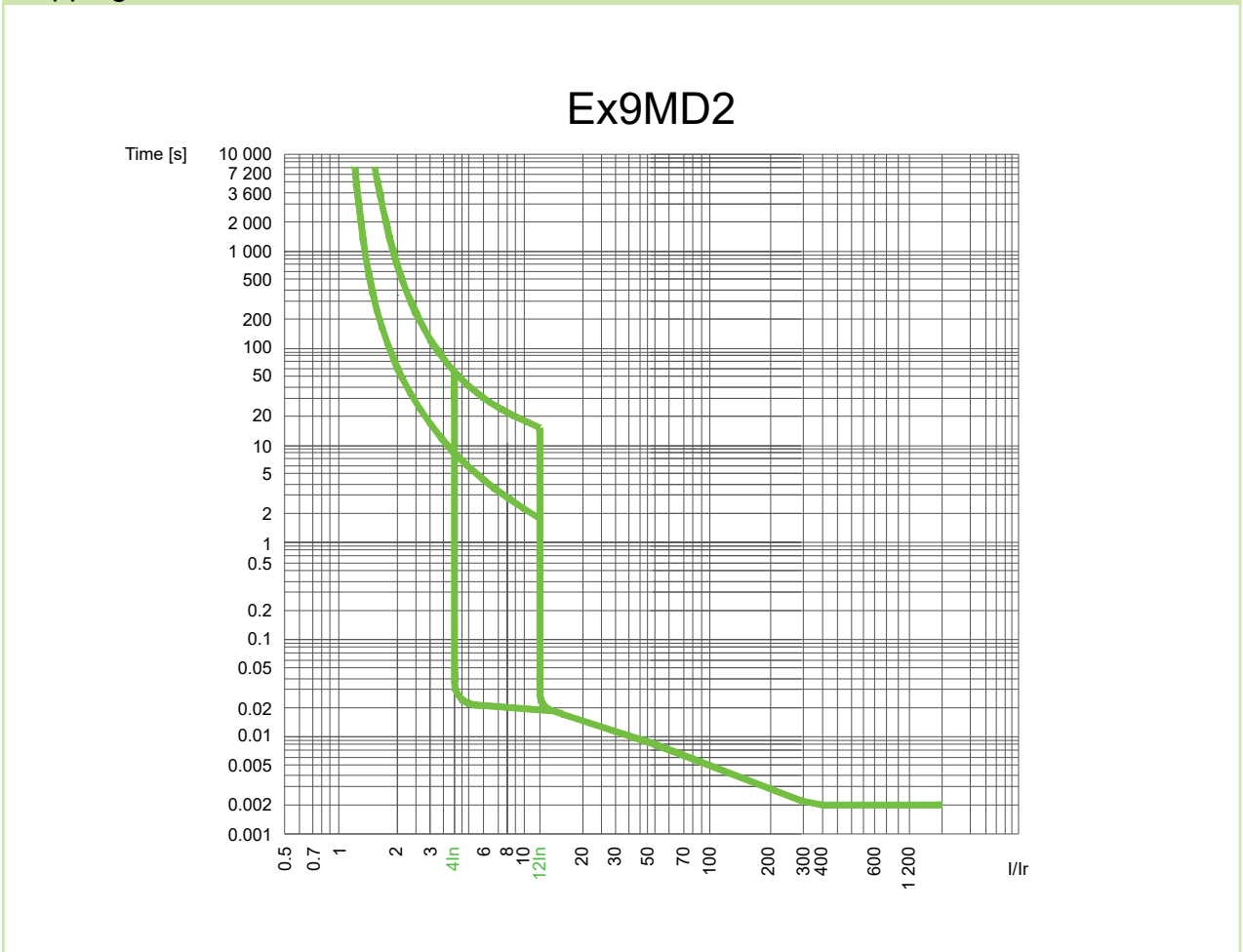

# Technical Data Ex9MD3

## DC Moulded Case Circuit Breakers up to 400 A

### General parameters

Suitable for PV and similar applications

Thermal release adjustable  $(0.8-0.9-1) \times I_n$

Instantaneous short-circuit current release  $(5-6-7-8-9-10) \times I_n$

Internal accessories

Auxiliary contact unit	AX21	101395
Alarm contact unit	AL21	101396
Early-make auxiliary contact	EC 23	106317
Shunt trip releases	SHT22	101416-101424
Undervoltage releases	UVT22	101425-101426

Max. number of installed internal accessories is 3 pcs of AX21, 1 pc of AL21 or EC 23 and 1 pc of a release (SHT22 or UVT22)

External accessories

Direct rotary handle	RHD23	101429
Extended rotary handle	ERH23	101428
Remote motor operators	MOD23	101430-101434
Terminal cover, short	TCV23 3P, TCV23 4P	101442, 102376
Terminal cover, long	TCE23 3P, TCE23 4P	101443, 102377
Phase barrier set	PB23 3P, PB23 4P	101444, 102340
Connection terminals	MC23	103715-103722

Mounting screws, interconnection busbars as well as phase barriers in the scope of delivery

### Electrical parameters

	Ex9MD3B	Ex9MD3S	Ex9MD3N	Ex9MD3H
Tested according to	IEC/EN 60947-2			
Rated op. voltage $U_e$	750 (3P), 1000 V DC (4P)			
Rated insulation voltage $U_i$	1000 V			
Rated impulse withstand voltage $U_{imp}$	8 kV			
Rated ultimate short-circuit breaking capacity $I_{cu}$	25 kA / 1000 V DC	36 kA / 1000 V DC	50 kA / 1000 V DC	100 kA / 1000 V DC
Rated service short-circuit breaking capacity $I_{cs}$	25 kA / 1000 V DC	36 kA / 1000 V DC	50 kA / 1000 V DC	100 kA / 1000 V DC
Rated short-circuit making capacity $I_{cm}$	52.5 kA / 1000 V DC	75.6 kA / 1000 V DC	105 kA / 1000 V DC	220 kA / 1000 V DC
Rated current	250 — 400 A			
Overvoltage category	III			
Utilization category	A			
Mechanical service life	10 000 operation cycles			
Electrical service life	2 000 operation cycles			
Maximum frequency of switch. cycles	60 cycles per hour			
Total disconnection time at short circuit	< 2 ms			
Power loss per pole at 400 A	25 W			

# Technical Data Ex9MD3

## DC Moulded Case Circuit Breakers up to 400 A

### Mechanical parameters

Device width (3P / 4P)	140 mm / 185 mm
Device height	255 mm
Device depth	118.5 mm
Mounting	onto panel
Degree of protection	IP40, IP20 terminals
Terminals	M10 screws
Busbar thickness	≤ 8 mm
Busbar width	≤ 30 mm
Cable lug width	≤ 30 mm
Fastening torque of terminals	25 — 30 Nm
Ambient temperature	-25 — +70 °C
Altitude	≤ 2 000 m
Relative humidity	≤ 50 % at 40 °C, ≤ 90 % monthly average
Resistance to humidity and heat	class 2
Pollution degree	3
Weight (3P / 4P)	5 kg / 6.6 kg
Mounting position	vertical, can be rotated by 90° in each axis

### Wiring diagram

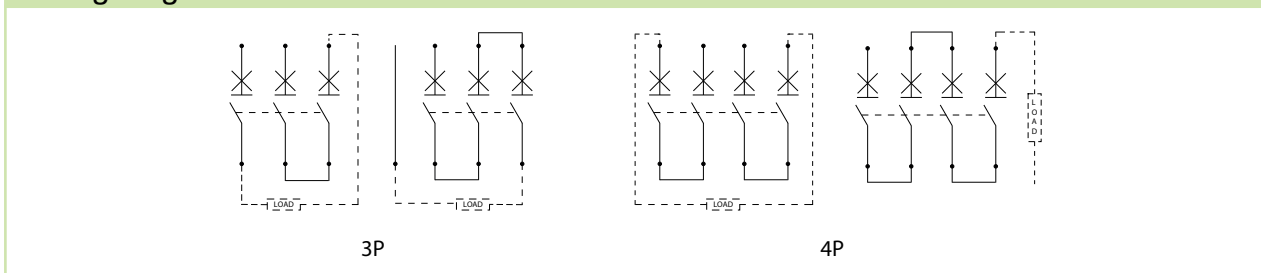

### Dimensions

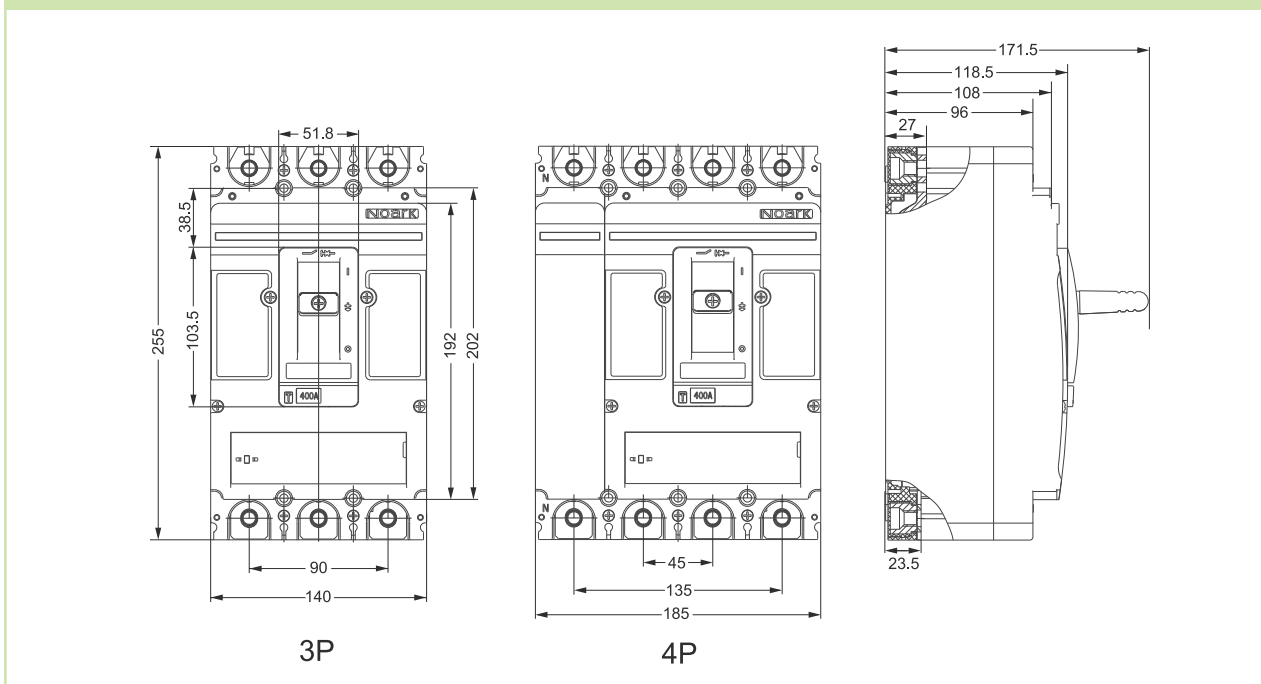

# Technical Data Ex9MD3

## DC Moulded Case Circuit Breakers up to 400 A

### Installation space

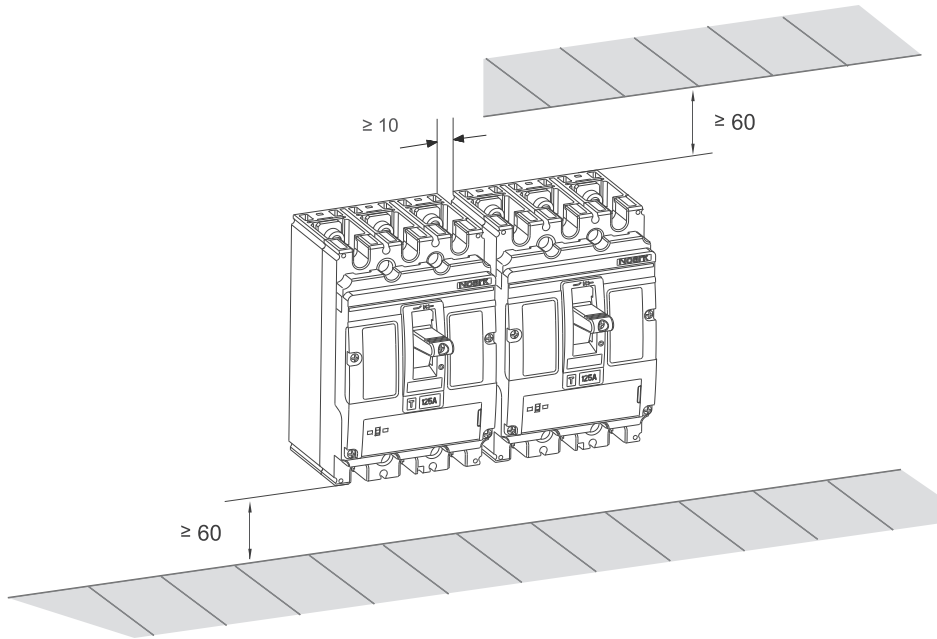

### Tripping characteristics

## Ex9MD3

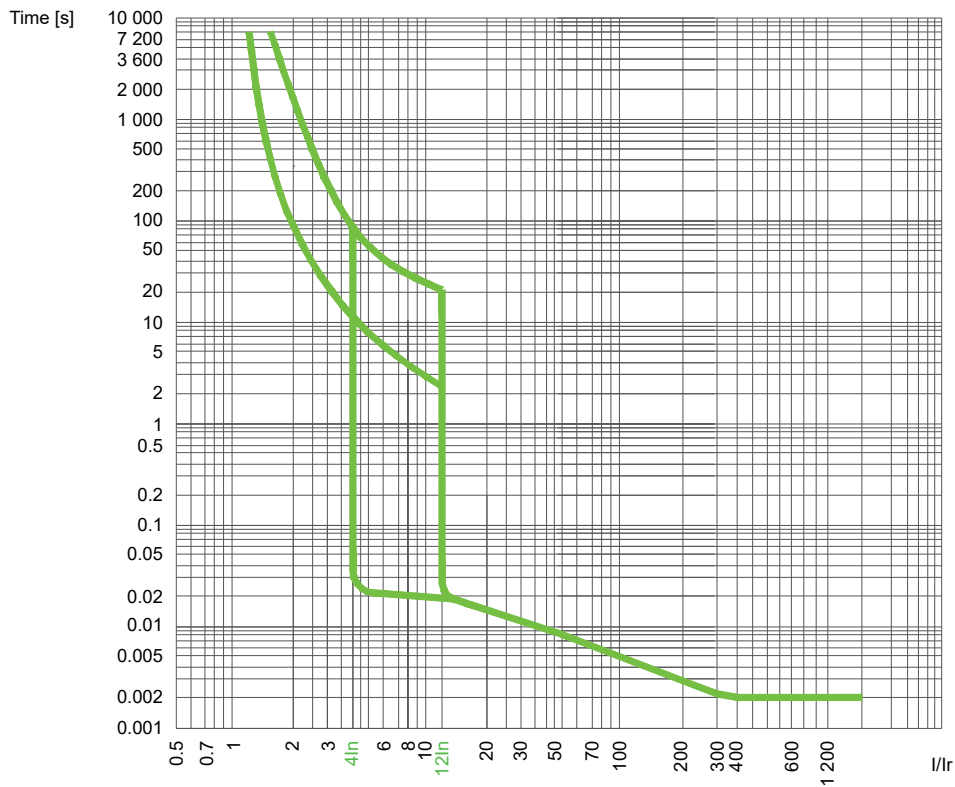



# Technical Data Ex9MD4

## DC Moulded Case Circuit Breakers up to 630 A

### General parameters

Suitable for PV and similar applications

Thermal release adjustable  $(0.8-0.9-1) \times I_n$

Instantaneous short-circuit current release  $(5-6-7-8-9-10) \times I_n$

Internal accessories

Auxiliary contact unit	AX21	101395
Alarm contact unit	AL21	101396
Early-make auxiliary contact	EC 23	106317
Shunt trip releases	SHT24	103723
Undervoltage releases	UVT24	103733-103740

Max. number of installed internal accessories is 4 pcs of AX21, 1 pc of AL21 or EC 23 and 1 pc of a release (SHT24 or UVT24)

External accessories

Direct rotary handle	RHD24	103742
Extended rotary handle	ERH24	103741
Remote motor operators	MOD24	103743-103747
Terminal cover, short	TCV24 3P, TCV24 4P	103748, 103750
Terminal cover, long	TCE24 3P, TCE24 4P	103749, 104855
Phase barrier set	PB24 3P, PB24 4P	103751, 104856
Connection terminals	MC24	106314

Mounting screws, interconnection busbars as well as phase barriers in the scope of delivery

### Electrical parameters

	Ex9MD4B	Ex9MD4S	Ex9MD4N	Ex9MD4H
Tested according to	IEC/EN 60947-2			
Rated op. voltage $U_e$	750 (3P), 1000 V DC (4P)			
Rated insulation voltage $U_i$	1000 V			
Rated impulse withstand voltage $U_{imp}$	8 kV			
Rated ultimate short-circuit breaking capacity $I_{cu}$	25 kA / 1000 V DC	36 kA / 1000 V DC	50 kA / 1000 V DC	100 kA / 1000 V DC
Rated service short-circuit breaking capacity $I_{cs}$	25 kA / 1000 V DC	36 kA / 1000 V DC	50 kA / 1000 V DC	100 kA / 1000 V DC
Rated short-circuit making capacity $I_{cm}$	25 kA / 1000 V DC	36 kA / 1000 V DC	50 kA / 1000 V DC	100 kA / 1000 V DC
Rated current	400 — 630 A			
Overvoltage category	III			
Utilization category	A			
Mechanical service life	10 000 operation cycles			
Electrical service life	2 000 operation cycles			
Maximum frequency of switch. cycles	60 cycles per hour			
Total disconnection time at short circuit	< 2 ms			
Power loss per pole at 630 A	31.8 W			

# Technical Data Ex9MD4

## DC Moulded Case Circuit Breakers up to 630 A

### Mechanical parameters

Device width (3P / 4P)	195 mm / 260 mm
Device height	300 mm
Device depth	142 mm
Mounting	onto panel
Degree of protection	IP40, IP20 terminals
Terminals	M13 screws
Busbar thickness	≤ 10 mm
Busbar width	≤ 50 mm
Cable lug width	≤ 50 mm
Fastening torque of terminals	25 — 30 Nm
Ambient temperature	-25 — +70 °C
Altitude	≤ 2 000 m
Relative humidity	≤ 50 % at 40 °C, ≤ 90 % monthly average
Resistance to humidity and heat	class 2
Pollution degree	3
Weight (3P / 4P)	10,2 kg / 13,5 kg
Mounting position	vertical, can be rotated by 90° in each axis

### Wiring diagram

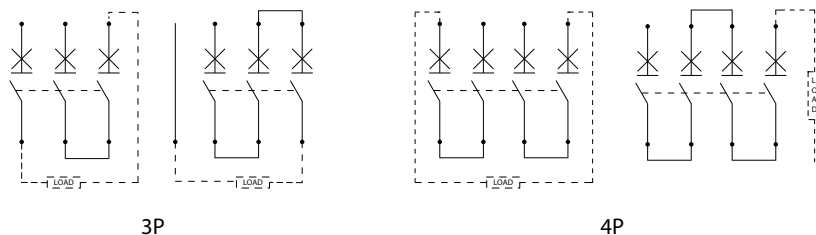

### Dimensions

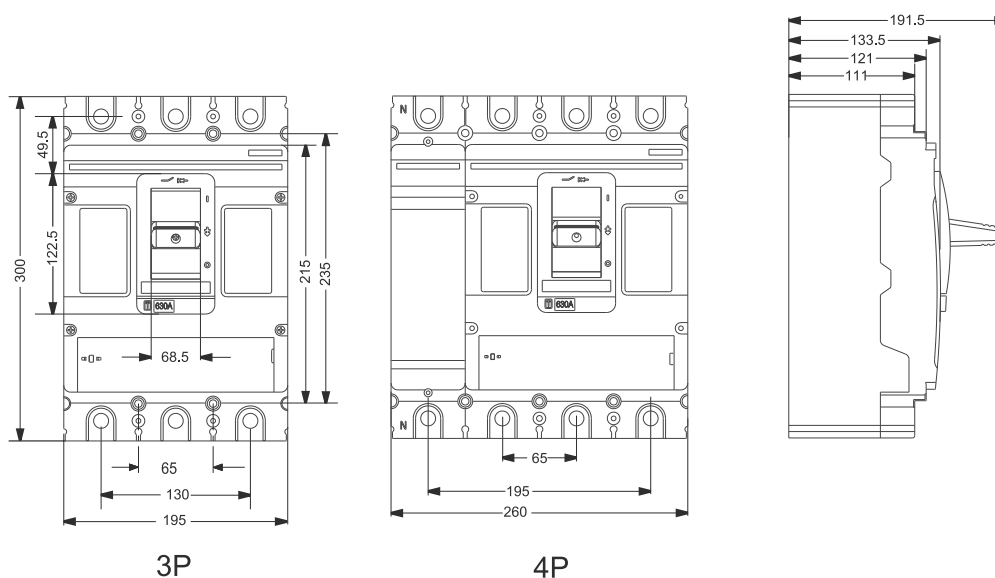

Ordering information p. 50

# Technical Data Ex9MD4

## DC Moulded Case Circuit Breakers up to 630 A

### Installation space

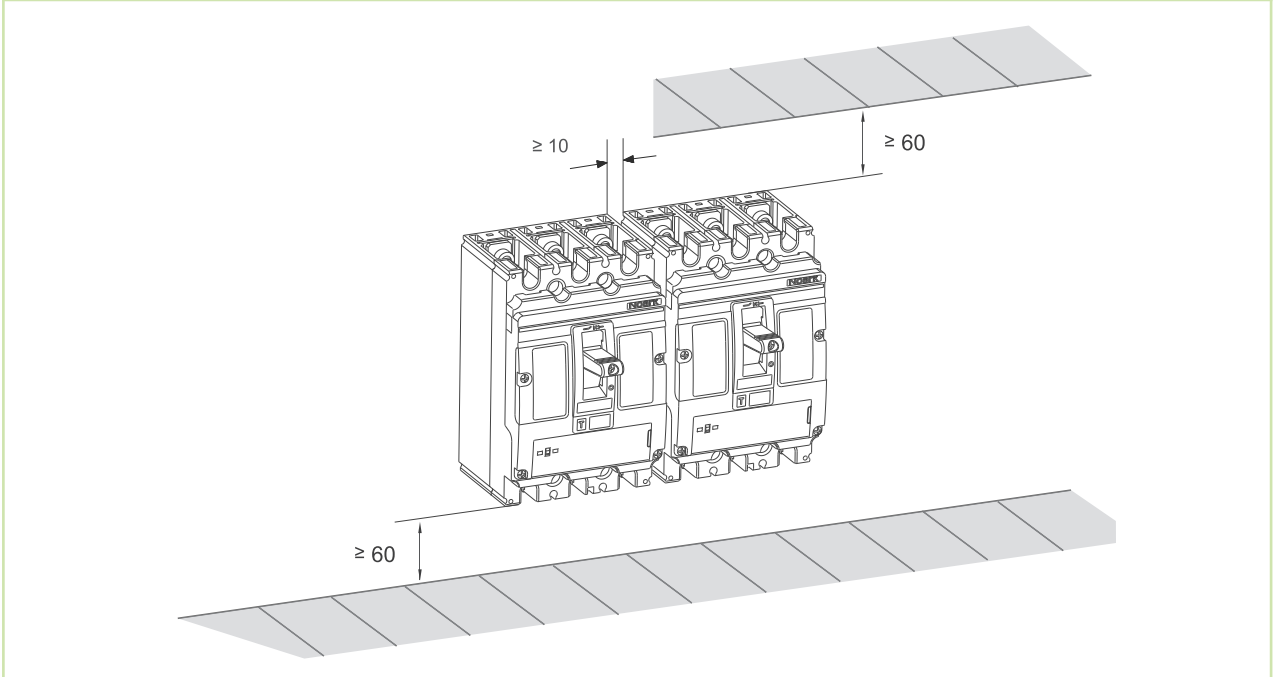

### Tripping characteristics

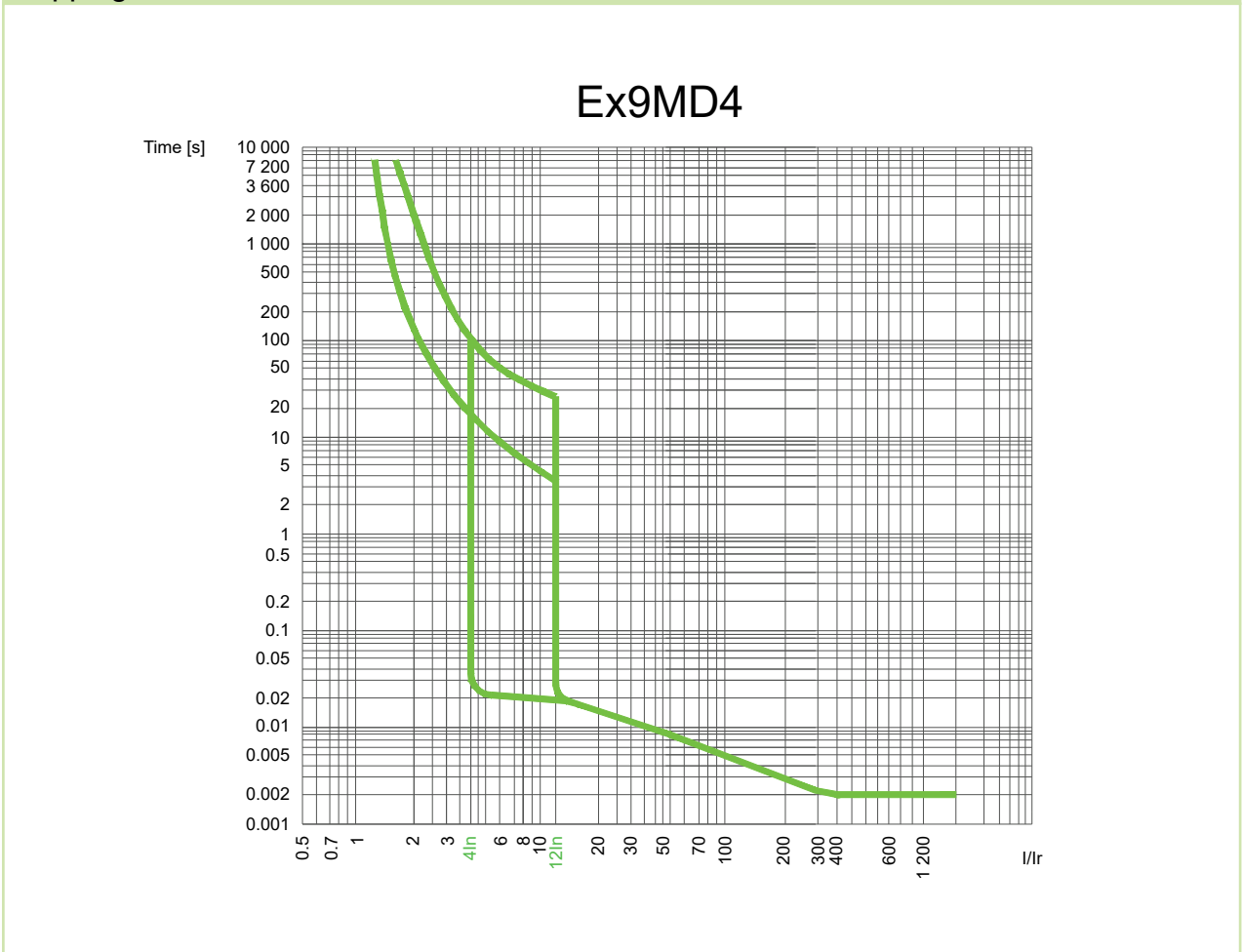

# Technical Data Ex9MD5

## DC Moulded Case Circuit Breakers up to 800 A

### General parameters

Suitable for PV and similar applications

Thermal release adjustable  $(0.8-0.9-1) \times I_n$

Instantaneous short-circuit current release  $(5-6-7-8-9-10) \times I_n$

Internal accessories

Auxiliary contact unit	AX21	101395
Alarm contact unit	AL21	101396
Early-make auxiliary contact	EC 23	106317
Shunt trip releases	SHT24	103723-103730
Undervoltage releases	UVT24	103733-103740

Max. number of installed internal accessories is 4 pcs of AX21, 1 pc of AL21 or EC 23 and 1 pc of a release (SHT24 or UVT24)

External accessories

Direct rotary handle	RHD24	103742
Extended rotary handle	ERH24	103741
Remote motor operators	MOD24	103743-103747
Terminal cover, short	TCV24 3P, TCV24 4P	103748, 103750
Terminal cover, long	TCE24 3P, TCE24 4P	103749, 104855
Phase barrier set	PB24 3P, PB24 4P	103751, 104856
Connection terminals	MC24	106314

Mounting screws, interconnection busbars as well as phase barriers in the scope of delivery

### Electrical parameters

	Ex9MD5B	Ex9MD5S	Ex9MD5N	Ex9MD5H
Tested according to	IEC/EN 60947-2			
Rated op. voltage $U_e$	750 (3P), 1000 V DC (4P)			
Rated insulation voltage $U_i$	1000 V			
Rated impulse withstand voltage $U_{imp}$	8 kV			
Rated ultimate short-circuit breaking capacity $I_{cu}$	25 kA / 1000 V DC	36 kA / 1000 V DC	50 kA / 1000 V DC	100 kA / 1000 V DC
Rated service short-circuit breaking capacity $I_{cs}$	25 kA / 1000 V DC	36 kA / 1000 V DC	50 kA / 1000 V DC	100 kA / 1000 V DC
Rated short-circuit making capacity $I_{cm}$	25 kA / 1000 V DC	36 kA / 1000 V DC	50 kA / 1000 V DC	100 kA / 1000 V DC
Rated current	630 — 800 A			
Overvoltage category	III			
Utilization category	A			
Mechanical service life	5 000 operation cycles			
Electrical service life	1 000 operation cycles			
Maximum frequency of switch. cycles	60 cycles per hour			
Total disconnection time at short circuit	< 2 ms			
Power loss per pole at 400 A	51.2 W			

# Technical Data Ex9MD5

## DC Moulded Case Circuit Breakers up to 800 A

### Mechanical parameters

Device width (3P / 4P)	195 mm / 260 mm
Device height	300 mm
Device depth	142 mm
Mounting	onto panel
Degree of protection	IP40, IP20 terminals
Terminals	M13 screws
Busbar thickness	≤ 10 mm
Busbar width	≤ 50 mm
Cable lug width	≤ 50 mm
Fastening torque of terminals	25 — 30 Nm
Ambient temperature	-25 — +70 °C
Altitude	≤ 2 000 m
Relative humidity	≤ 50 % at 40 °C, ≤ 90 % monthly average
Resistance to humidity and heat	class 2
Pollution degree	3
Weight (3P / 4P)	10,2 kg / 13,5 kg
Mounting position	vertical, can be rotated by 90° in each axis

### Wiring diagram

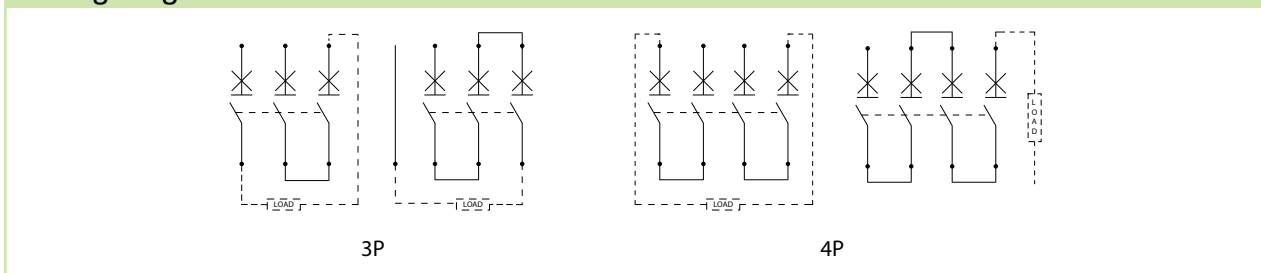

### Dimensions

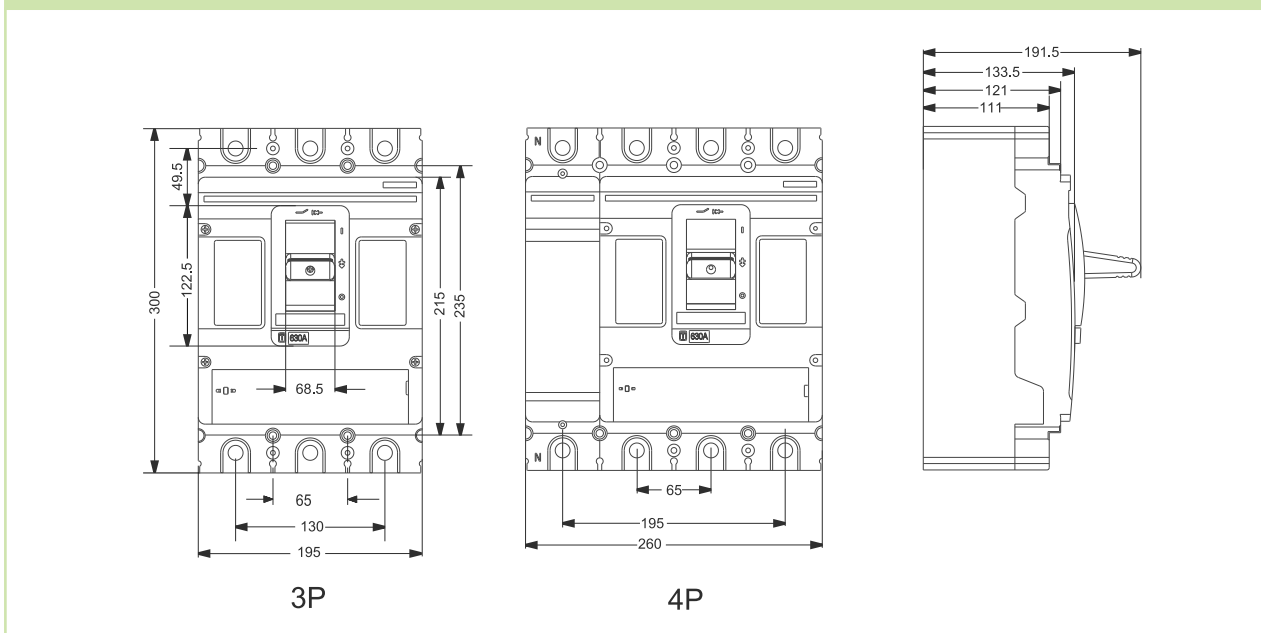

# Technical Data Ex9MD5

## DC Moulded Case Circuit Breakers up to 800 A

### Installation space

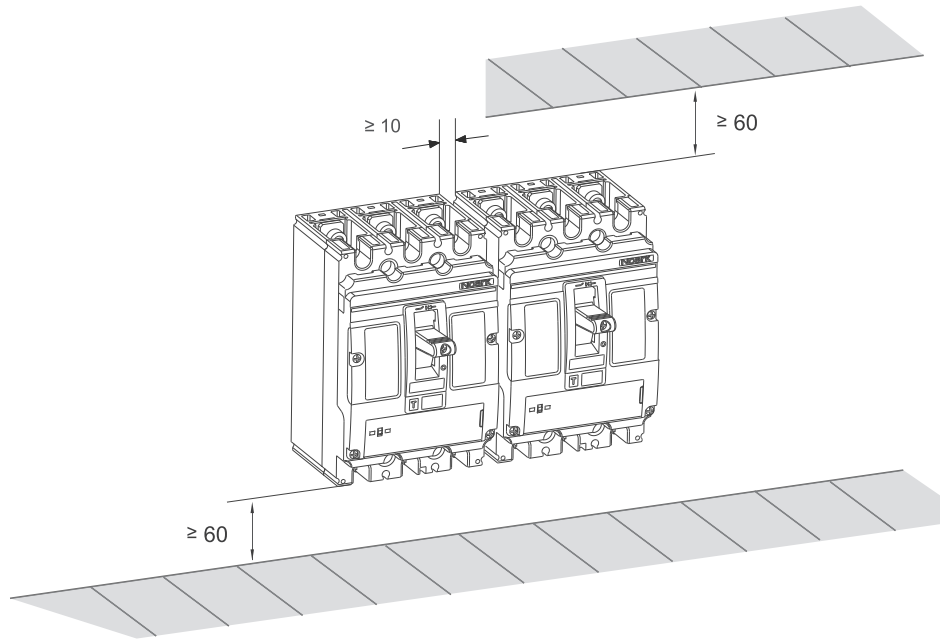

### Tripping characteristics

## Ex9MD5

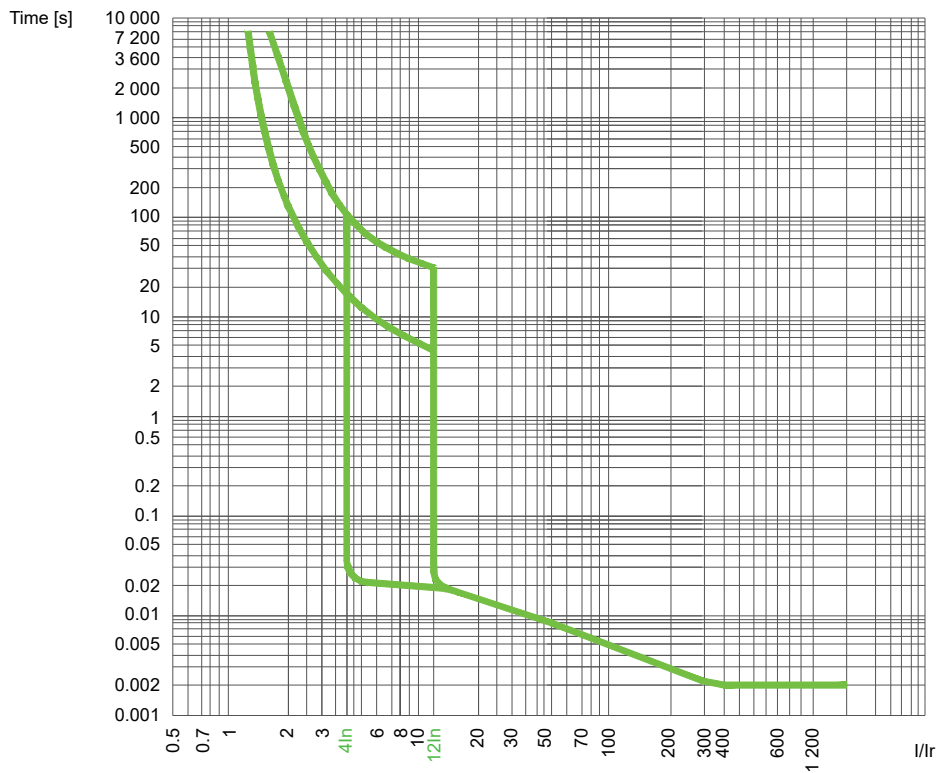

# Technical Data Ex9MV2S

## DC Moulded Case Circuit Breakers for photovoltaic

### General parameters

Suitable for photovoltaics application

#### Internal accessories

Left auxiliary contact unit	AX22V	110199
	2AX22V	110200
Right auxiliary contact unit	AX22VR	110206
	2AX22VR	110207
Left alarm contact unit	AL22V	110201
Left auxiliary + alarm contact unit	AX+AL22V	110202
Right shunt trip releases	SHT22VR	110208-110210

#### External accessories

Extended rotary handle	ERH-1	110211
------------------------	-------	--------

Mounting screws as well as phase barriers in the scope of delivery

### Accessories position

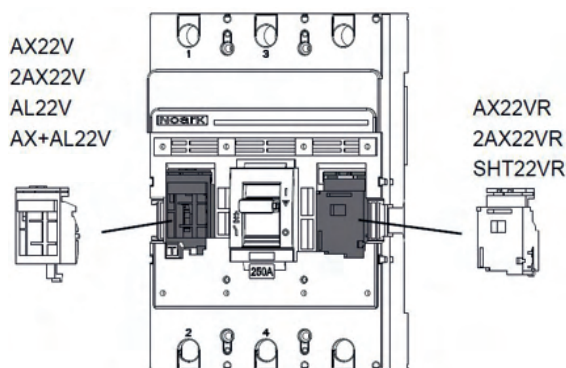

### Electrical parameters

Tested according to	IEC/EN 60947-2			
Rated op. voltage $U_e$	1500 V DC			
Rated insulation voltage $U_i$	1500 V			
Rated impulse withstand voltage $U_{imp}$	12 kV			
Rated ultimate short-circuit breaking capacity $I_{cu}$	15 kA			
Rated service short-circuit breaking capacity $I_{cs}$	15 kA			
Rated current	125 A, 160 A, 200 A, 225 A, 250 A			
Utilization category	A			
Electrical service life	2 000 operation cycles			
Maximum frequency of switch. cycles	120 cycles per hour			
Total disconnection time at short circuit	< 40 ms			
Power loss per pole	max 32 W			
Altitude	2000 m	3000 m	4000 m	5000 m
Rated operational current $I_n$	$1 \times I_n$	$0.97 \times I_n$	$0.93 \times I_n$	$0.89 \times I_n$
Rated operational voltage $U_e$	1500 V DC	1350 V DC	1200 V DC	1050 V DC
Rated insulation voltage $U_i$	1500 V	1500 V	1500 V	1500 V
Dielectric properties	3110 V DC	2890 V DC	2700 V DC	2500 V DC

# Technical Data Ex9MV2S

## DC Moulded Case Circuit Breakers for photovoltaic

### Mechanical parameters

Device width	135 mm
Device height	200 mm
Device depth	103 mm
Mounting	onto panel
Degree of protection	IP20
Mechanical service life	10 000 operation cycles
Terminals	M10 screws
Busbar thickness	≤ 4 mm
Busbar width	≤ 29 mm
Cable lug width	≤ 50 mm
Fastening torque of terminals	25 Nm
Ambient temperature	-40 — +70 °C
Relative humidity	≤ 50 % at 40 °C, ≤ 90 % at 20 °C
Pollution degree	3
Weight	3.3 kg
Mounting position	vertical, can be rotated by 90° in each axis

### Wiring diagram

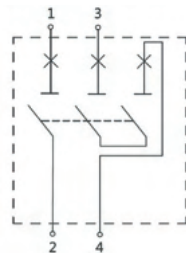

### Dimensions

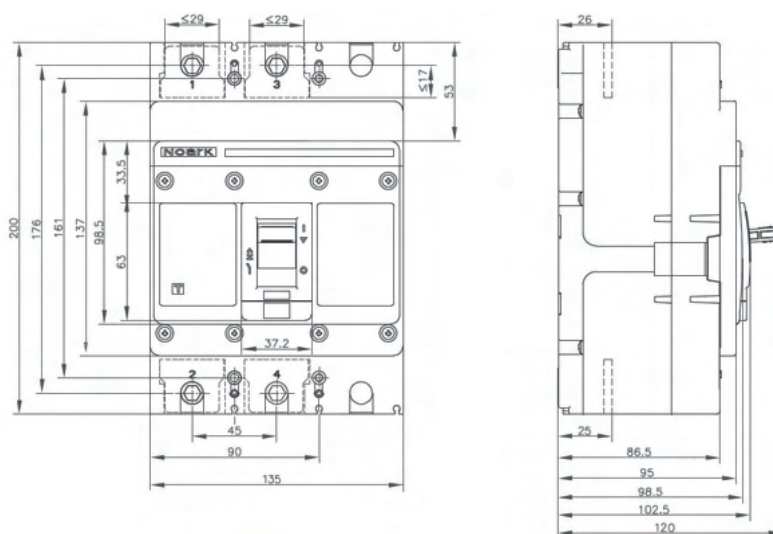



# Technical Data Ex9MV2S

## DC Moulded Case Circuit Breakers for photovoltaic

### Installation space

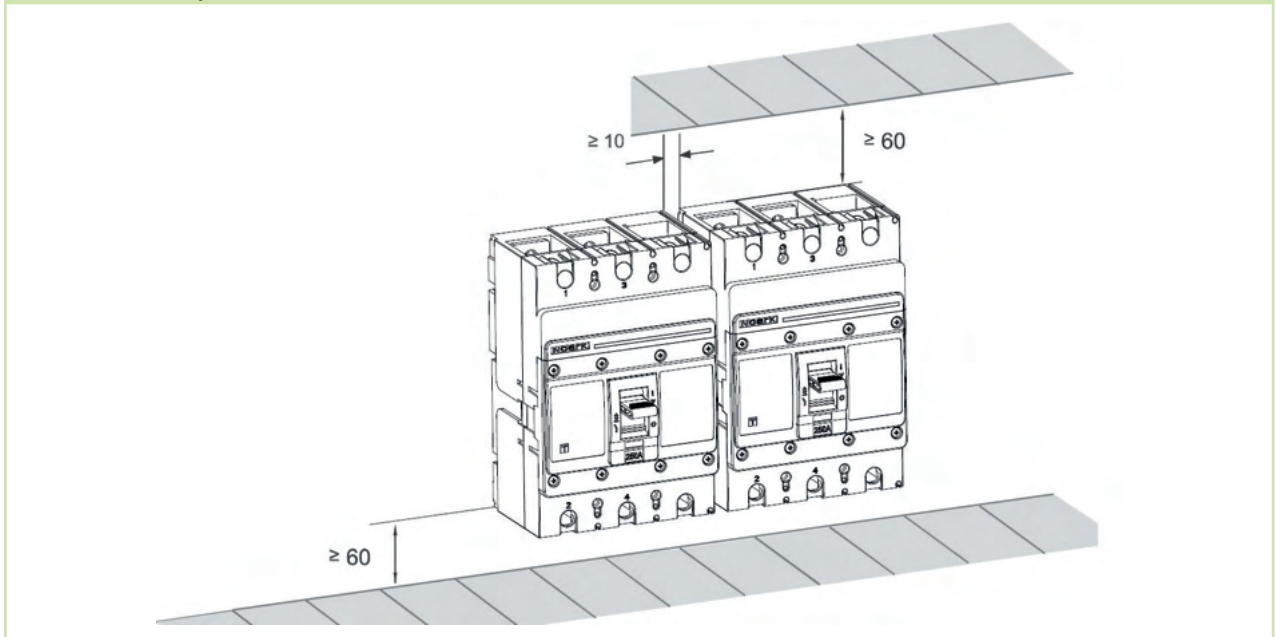

### Tripping characteristics

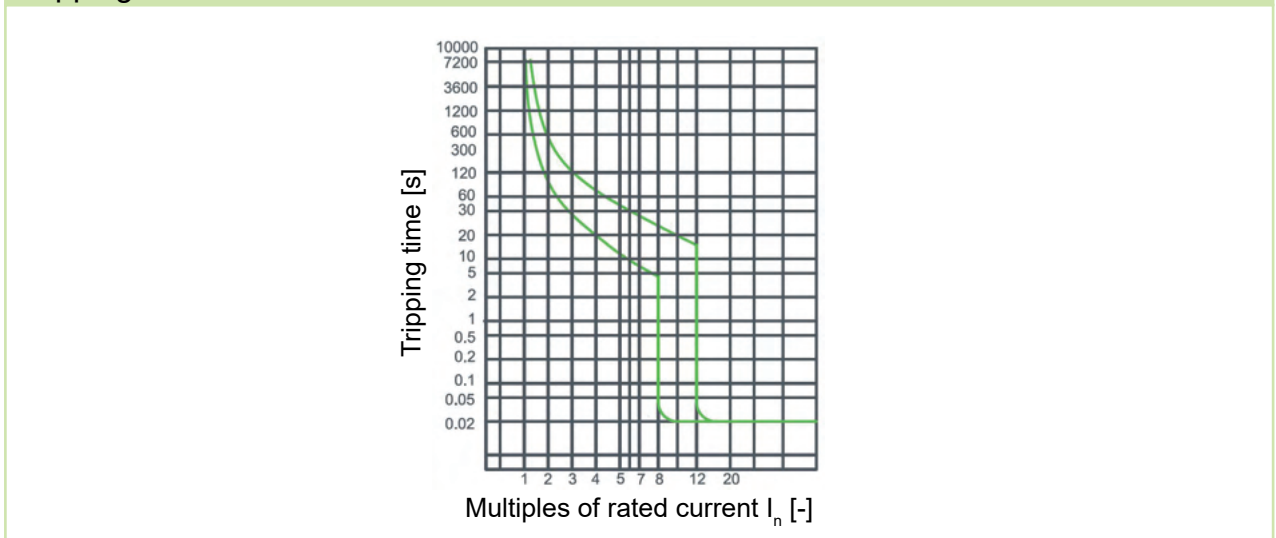

### Temperature derating curve

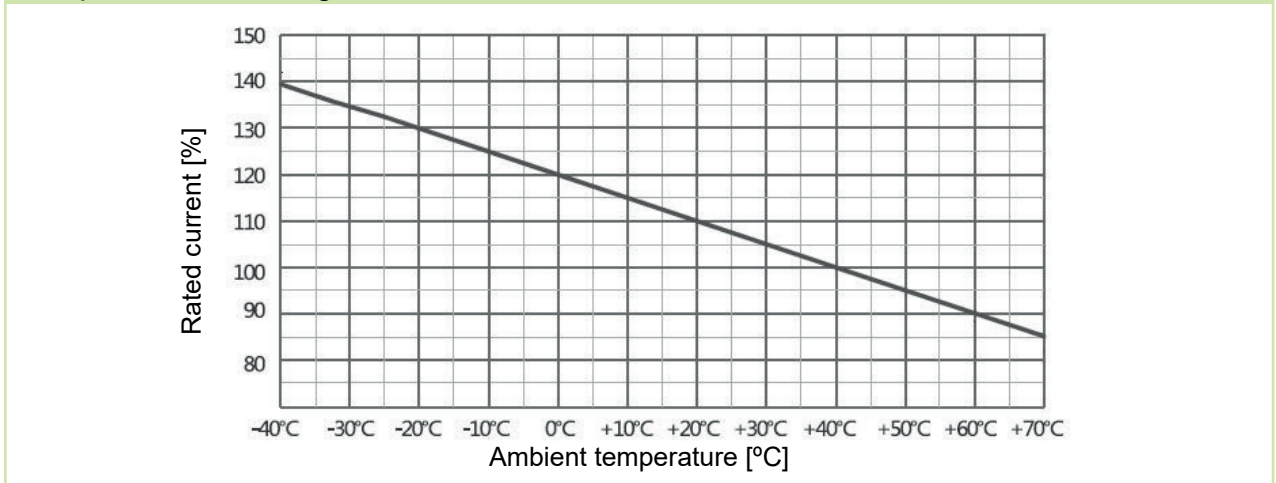

# Technical Data Ex9M1SD DC

## DC MCCB Switch Disconnectors up to 125 A

### General parameters

Suitable for PV and other DC applications

#### Internal accessories

Auxiliary contact unit	AX21	101395
Early-make auxiliary contact	EC 21	106315
Shunt trip releases	SHT21	101397-101405
Undervoltage releases	UVT21	101406-101407

Max. number of installed internal accessories is 2 pcs of AX21, 1 pc of EC 21 and 1 pc of a release (SHT21 or UVT21)

#### External accessories

Direct rotary handle	RHD21	101410
Extended rotary handle	ERH21	101409
Remote motor operators	MOD21	101411-101415
Terminal cover, short	TCV21 3P, TCV21 4P	101439, 102372
Terminal cover, long	TCE21 3P, TCE21 4P	101440, 102373
Phase barrier set	PB21 3P, 4P	101441, 104852
Connection terminals	MC21	103705-103708
DIN-rail mounting adaptor	DRA21	106319

Mounting screws, interconnection busbars as well as phase barriers in the scope of delivery

### Electrical parameters

Tested according to	IEC/EN 60947-3
Rated operating voltage $U_e$	750 V DC (3P) 1000 V DC (4P)
Rated insulation voltage $U_i$	1000 V DC
Rated impulse withstand voltage $U_{imp}$	8 kV
Rated current $I_n$	63 — 125 A
Rated short time withstand current $I_{cw}$	
1 s	1 800 A
3 s	1 800 A
Rated short time making capacity $I_{cm}$	3 kA
Overvoltage category	III
Utilization category	A
Mechanical service life	15 000 operation cycles
Electrical service life	5 000 operation cycles
Maximum frequency of switch. cycles	120 cycles per hour

# Technical Data Ex9M1SD DC

## DC MCCB Switch Disconnectors up to 125 A

### Mechanical parameters

Device width (3P / 4P)	90 mm / 120 mm
Device height	140 mm
Device depth	81.6 mm
Mounting	onto panel
Degree of protection	IP40, IP20 terminals
Terminals	M6 screws
Busbar thickness	≤ 4 mm
Busbar width	≤ 14.2 mm
Cable lug width	≤ 14.2 mm
Fastening torque of terminals	10 — 15 Nm
Ambient temperature	-25 — +70 °C
Altitude	≤ 2 000 m
Relative humidity	≤ 50 % at 40 °C, ≤ 90 % monthly average
Resistance to humidity and heat	class 2
Pollution degree	3
Weight (3P / 4P)	1.0 kg / 1.5 kg
Mounting position	vertical, can be rotated by 90° in each axis

### Wiring diagram

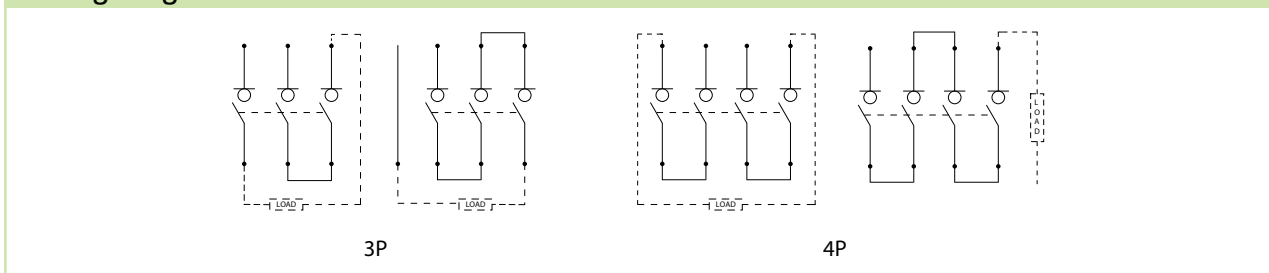

# Technical Data Ex9M1SD DC

## DC MCCB Switch Disconnectors up to 125 A

### Dimensions

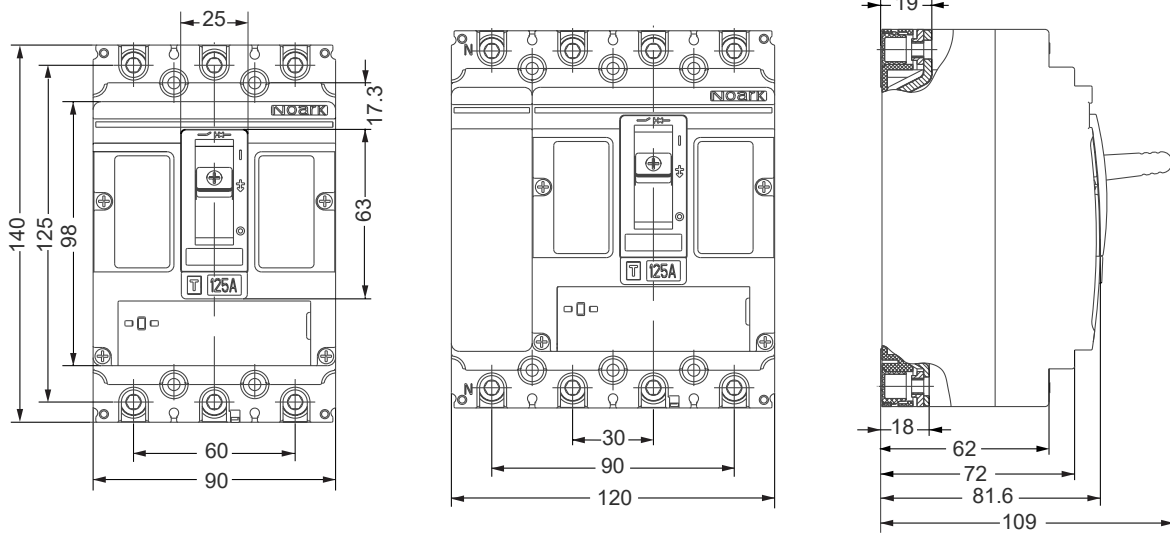

### Installation space

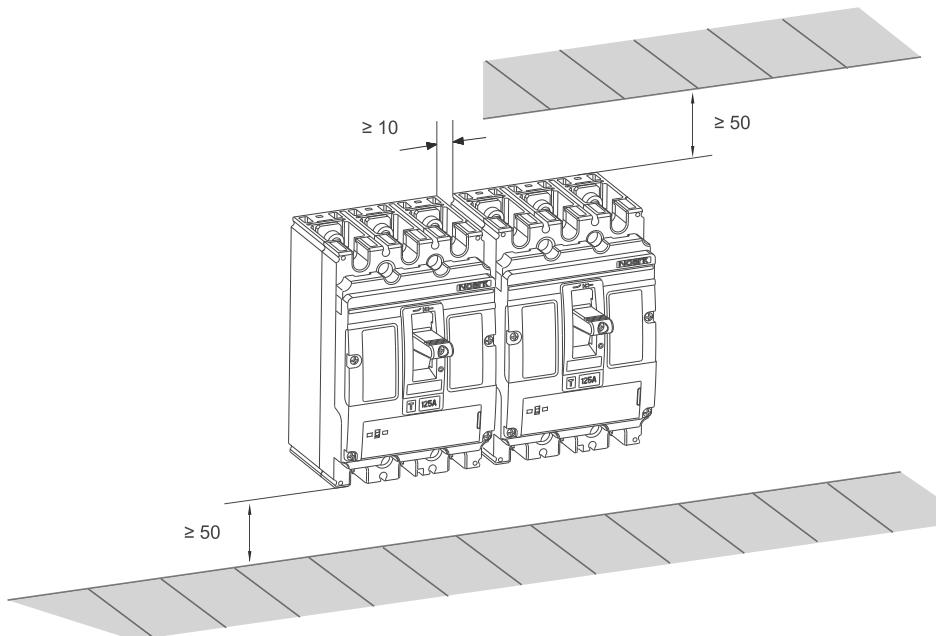

Ordering information p. 60

# Technical Data Ex9M2SD DC

## DC MCCB Switch Disconnectors up to 250 A

### General parameters

Suitable for PV and other DC applications		
Internal accessories		
Auxiliary contact unit	AX21	101395
Early-make auxiliary contact	EC 21	106315
Shunt trip releases	SHT22	101416-101424
Undervoltage releases	UVT22	101425-101426
Max. number of installed internal accessories is 2 pcs of AX21, 1 pc of EC 21 and 1 pc of a release (SHT22 or UVT22)		
External accessories		
Direct rotary handle	RHD22	101429
Extended rotary handle	ERH22	101428
Remote motor operators	MOD22	101430-101434
Terminal cover, short	TCV22 3P, TCV22 4P	101442, 102374
Terminal cover, long	TCE22 3P, TCE22 4P	101443, 102375
Phase barrier set	PB22 3P, 4P	101444, 104853
Connection terminals	MC22	103709-103714
DIN-rail mounting adaptor	DRA22	106320
Mounting screws, interconnection busbars as well as phase barriers in the scope of delivery		

### Electrical parameters

Tested according to	IEC/EN 60947-3
Rated operating voltage $U_e$	750 V DC (3P) 1000 V DC (4P)
Rated insulation voltage $U_i$	1000 V DC
Rated impulse withstand voltage $U_{imp}$	8 kV
Rated current $i_n$	125 — 250 A
Rated short time withstand current $I_{cw}$	
1 s	3 200 A
3 s	3 200 A
Rated short time making capacity $I_{cm}$	5 kA
Overvoltage category	III
Utilization category	A
Mechanical service life	15 000 operation cycles
Electrical service life	5 000 operation cycles
Maximum frequency of switch. cycles	120 cycles per hour

# Technical Data Ex9M2SD DC

## DC MCCB Switch Disconnectors up to 250 A

### Mechanical parameters

Device width (3P / 4P)	105 mm / 140 mm
Device height	157 mm
Device depth	91.5 mm
Mounting	onto panel
Degree of protection	IP40, IP20 terminals
Terminals	M8 screws
Busbar thickness	≤ 6 mm
Busbar width	≤ 25 mm
Cable lug width	≤ 25 mm
Fastening torque of terminals	15 Nm
Ambient temperature	-25 — +70 °C
Altitude	≤ 2 000 m
Relative humidity	≤ 50 % at 40 °C, ≤ 90 % monthly average
Resistance to humidity and heat	class 2
Pollution degree	3
Weight (3P / 4P)	1.5 / 2.0 kg
Mounting position	vertical, can be rotated by 90° in each axis

### Wiring diagram

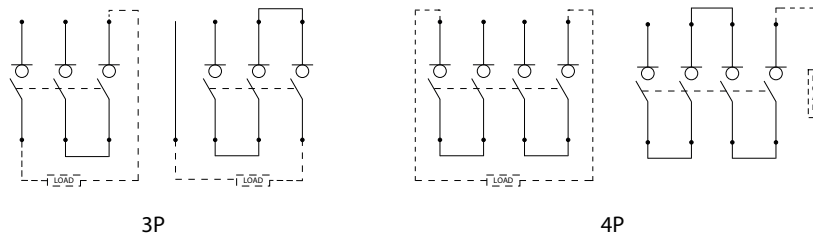

# Technical Data Ex9M2SD DC

## DC MCCB Switch Disconnectors up to 250 A

### Dimensions

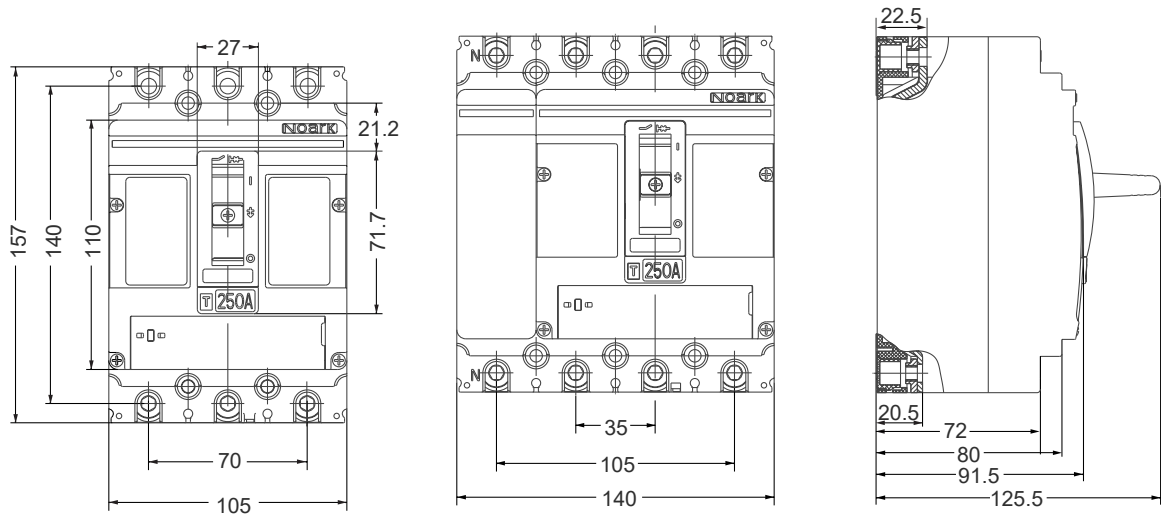

### Installation space

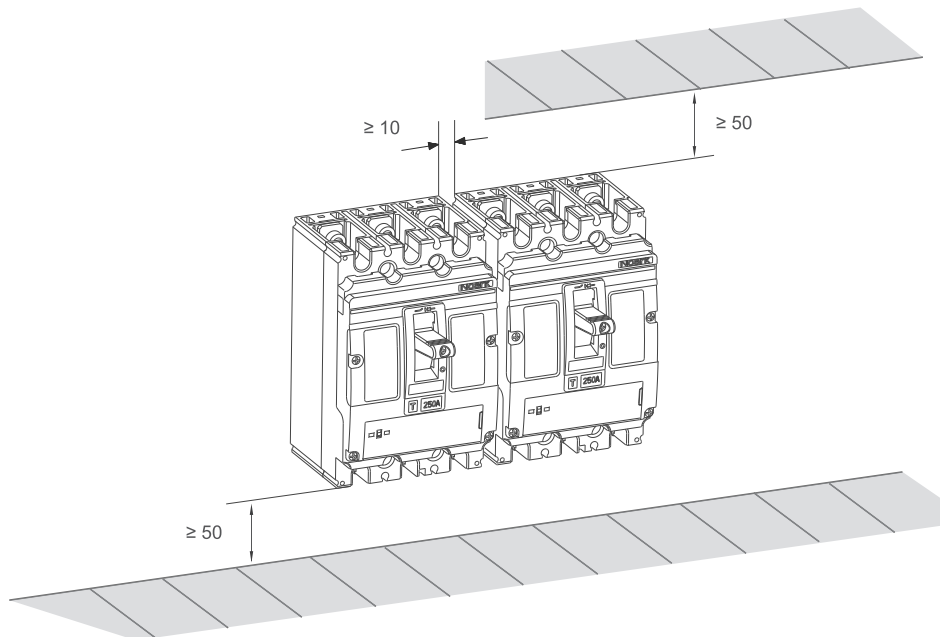

# Technical Data Ex9M3SD DC

## DC MCCB Switch Disconnectors up to 400 A

### General parameters

Suitable for PV and other DC applications

#### Internal accessories

Auxiliary contact unit	AX21	101395
Early-make auxiliary contact	EC 23	106317
Shunt trip releases	SHT22	101416-101424
Undervoltage releases	UVT22	101425-101426

Max. number of installed internal accessories is 3 pcs of AX21, 1 pc of EC 23 and 1 pc of a release (SHT22 or UVT22)

#### External accessories

Direct rotary handle	RHD23	101483
Extended rotary handle	ERH23	101482
Remote motor operators	MOD23	101484-101488
Terminal cover, short	TCV23 3P, TCV23 4P	101489, 102376
Terminal cover, long	TCE23 3P, TCE23 4P	101490, 102377
Phase barrier set	PB23 3P, 4P	101491, 104854
Connection terminals	MC23	103715-103722

Mounting screws, interconnection busbars as well as phase barriers in the scope of delivery

### Electrical parameters

Tested according to	IEC/EN 60947-3
Rated operating voltage $U_e$	750 V DC (3P) 1000 V DC (4P)
Rated insulation voltage $U_i$	1000 V DC
Rated impulse withstand voltage $U_{imp}$	8 kV
Rated current $I_n$	250 — 400 A
Rated short time withstand current $I_{cw}$	
1 s	5 000 A
3 s	5 000 A
Rated short time making capacity $I_{cm}$	7.7 kA
Overvoltage category	III
Utilization category	A
Mechanical service life	10 000 operation cycles
Electrical service life	2 000 operation cycles
Maximum frequency of switch. cycles	60 cycles per hour



# Technical Data Ex9M3SD DC

## DC MCCB Switch Disconnectors up to 400 A

### Mechanical parameters

Device width (3P / 4P)	140 mm / 185 mm
Device height	255 mm
Device depth	118.5 mm
Mounting	onto panel
Degree of protection	IP40, IP20 terminals
Terminals	M10 screws
Busbar thickness	≤ 8 mm
Busbar width	≤ 30 mm
Cable lug width	≤ 30 mm
Fastening torque of terminals	25 — 30 Nm
Ambient temperature	-25 — +70 °C
Altitude	≤ 2 000 m
Relative humidity	≤ 50 % at 40 °C, ≤ 90 % monthly average
Resistance to humidity and heat	class 2
Pollution degree	3
Weight (3P / 4P)	4.5 kg / 6 kg
Mounting position	vertical, can be rotated by 90° in each axis

### Wiring diagram

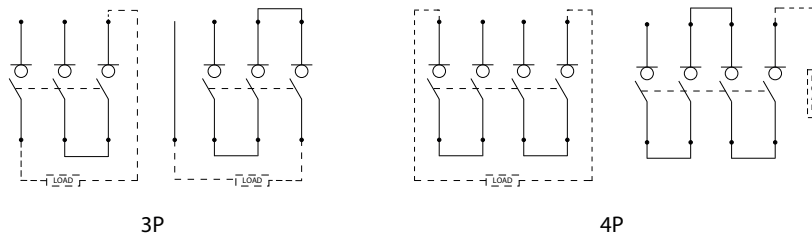

# Technical Data Ex9M3SD DC

DC MCCB Switch Disconnectors up to 400 A

## Dimensions

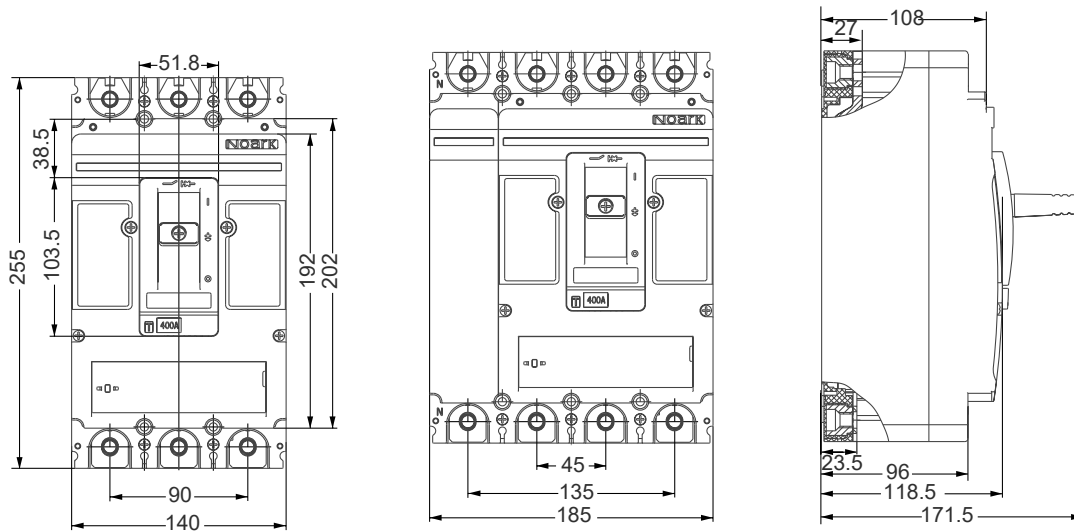

## Installation space

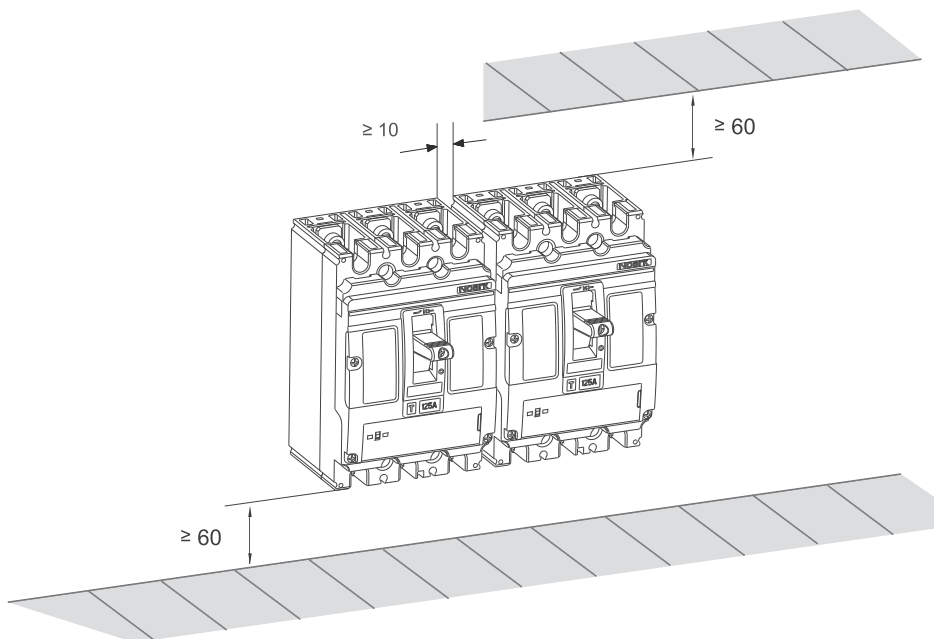

Ordering information p. 60

# Technical Data Ex9M4SD DC

## DC MCCB Switch Disconnectors up to 630 A

### General parameters

Suitable for PV and other DC applications

#### Internal accessories

Auxiliary contact unit	AX21	101395
Early-make auxiliary contact	EC 23	106317
Shunt trip releases	SHT24	103723-103730
Undervoltage releases	UVT24	103733-103740

Max. number of installed internal accessories is 4 pcs of AX21, 1 pc of EC 23 and 1 pc of a release (SHT24 or UVT24)

#### External accessories

Direct rotary handle	RHD24	103742
Extended rotary handle	ERH24	103741
Remote motor operators	MOD24	103743-103747
Terminal cover, short	TCV24 3P, 4P	103748, 103750
Terminal cover, long	TCE24 3P, 4P	103749, 104855
Phase barrier set	PB24 3P, 4P	103751, 104856
Connection terminals	MC24	106314

Mounting screws, interconnection busbars as well as phase barriers in the scope of delivery

### Electrical parameters

Tested according to	IEC/EN 60947-3
Rated operating voltage $U_e$	750 V DC (3P) 1000 V DC (4P)
Rated insulation voltage $U_i$	1000 V DC
Rated impulse withstand voltage $U_{imp}$	8 kV
Rated current $I_n$	630 A
Rated short time withstand current $I_{cw}$	
1 s	8 000 A
3 s	8 000 A
Rated short time making capacity $I_{cm}$	14 kA
Overvoltage category	III
Utilization category	A
Mechanical service life	5 000 operation cycles
Electrical service life	2 000 operation cycles
Maximum frequency of switch. cycles	60 cycles per hour

# Technical Data Ex9M4SD DC

## DC MCCB Switch Disconnectors up to 630 A

### Mechanical parameters

Device width (3P / 4P)	195 mm / 260 mm
Device height	300 mm
Device depth	142 mm
Mounting	onto panel
Degree of protection	IP40, IP20 terminals
Terminals	M12 screws
Busbar thickness	≤ 10 mm
Busbar width	≤ 50 mm
Cable lug width	≤ 50 mm
Fastening torque of terminals	25 — 30 Nm
Ambient temperature	-25 — +70 °C
Altitude	≤ 2 000 m
Relative humidity	≤ 50 % at 40 °C, ≤ 90 % monthly average
Resistance to humidity and heat	class 2
Pollution degree	3
Weight (3P / 4P)	9.5 kg / 12.7 kg
Mounting position	vertical, can be rotated by 90° in each axis

### Wiring diagram

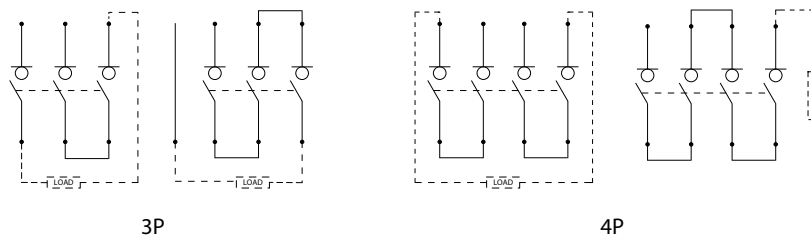

# Technical Data Ex9M4SD DC

DC MCCB Switch Disconnectors up to 630 A

## Dimensions

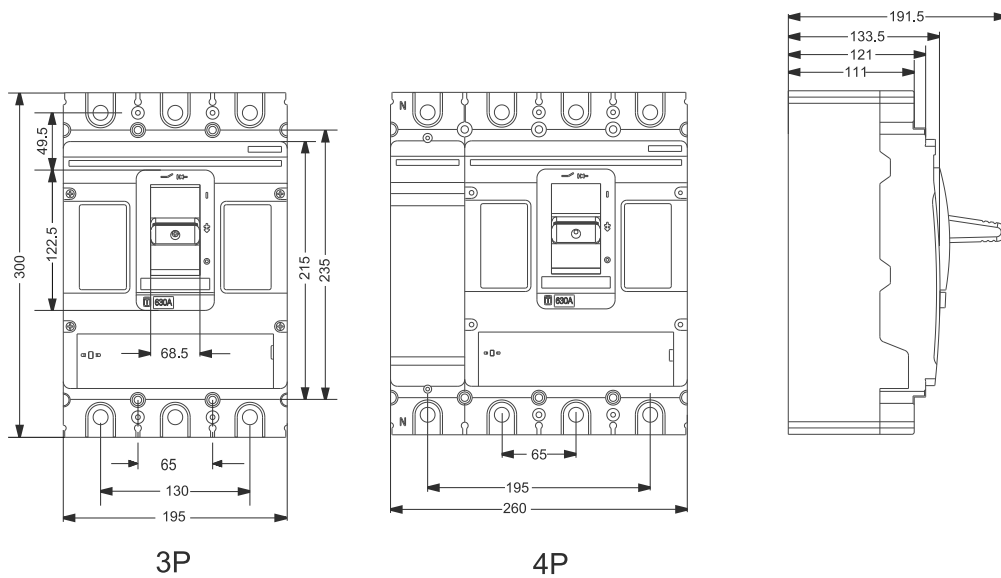

## Installation space

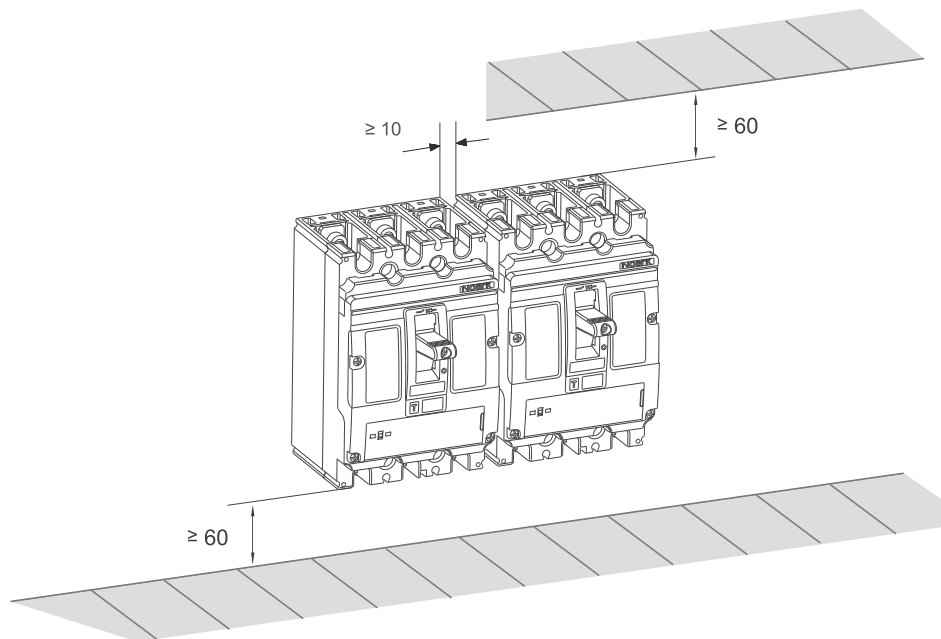

Ordering information p. 60

# Technical Data Ex9M5SD DC

## DC MCCB Switch Disconnectors up to 800 A

### General parameters

Suitable for PV and other DC applications

#### Internal accessories

Auxiliary contact unit	AX21	101395
Early-make auxiliary contact	EC 23	106317
Shunt trip releases	SHT24	103723-103730
Undervoltage releases	UVT24	103733-103740

Max. number of installed internal accessories is 4 pcs of AX21, 1 pc of EC 23 and 1 pc of a release (SHT24 or UVT24)

#### External accessories

Direct rotary handle	RHD24	103742
Extended rotary handle	ERH24	103741
Remote motor operators	MOD24	103743-103747
Terminal cover, short	TCV24 3P, 4P	103748, 103750
Terminal cover, long	TCE24 3P, 4P	103749, 104855
Phase barrier set	PB24 3P, 4P	103751, 104856
Connection terminals	MC24	106314

Mounting screws, interconnection busbars as well as phase barriers in the scope of delivery

### Electrical parameters

Tested according to	IEC/EN 60947-3
Rated operating voltage $U_e$	750 V DC (3P) 1000 V DC (4P)
Rated insulation voltage $U_i$	1000 V DC
Rated impulse withstand voltage $U_{imp}$	8 kV
Rated current $I_n$	800 A
Rated short time withstand current $I_{cw}$	
1 s	10 000 A
3 s	10 000 A
Rated short time making capacity $I_{cm}$	17 kA
Overvoltage category	III
Utilization category	A
Mechanical service life	5 000 operation cycles
Electrical service life	2 000 operation cycles
Maximum frequency of switch. cycles	60 cycles per hour

# Technical Data Ex9M5SD DC

## DC MCCB Switch Disconnectors up to 800 A

### Mechanical parameters

Device width (3P / 4P)	195 mm / 260 mm
Device height	300 mm
Device depth	142 mm
Mounting	onto panel
Degree of protection	IP40, IP20 terminals
Terminals	M12 screws
Busbar thickness	≤ 10 mm
Busbar width	≤ 50 mm
Cable lug width	≤ 50 mm
Fastening torque of terminals	25 — 30 Nm
Ambient temperature	-25 — +70 °C
Altitude	≤ 2 000 m
Relative humidity	≤ 50 % at 40 °C, ≤ 90 % monthly average
Resistance to humidity and heat	class 2
Pollution degree	3
Weight (3P / 4P)	9.5 kg / 12.7 kg
Mounting position	vertical, can be rotated by 90° in each axis

### Wiring diagram

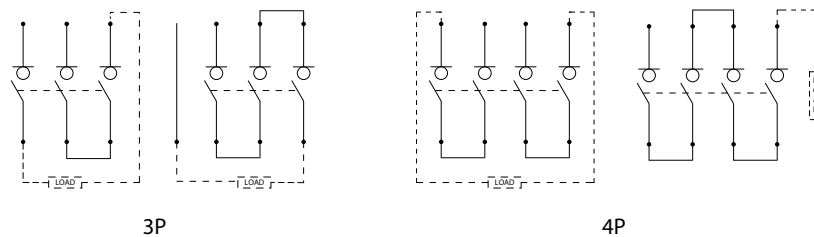

# Technical Data Ex9M5SD DC

DC MCCB Switch Disconnectors up to 800 A

## Dimensions

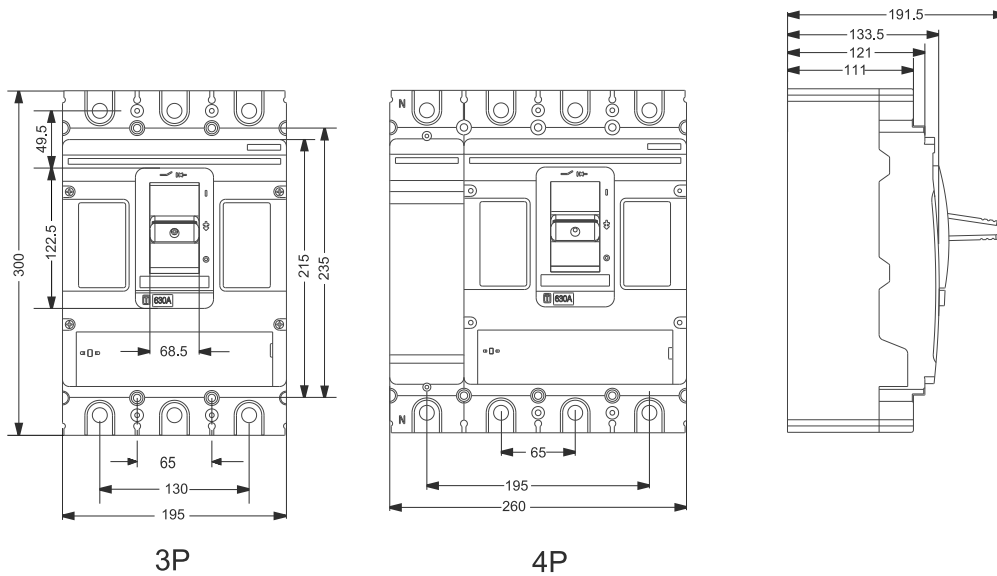

## Installation space

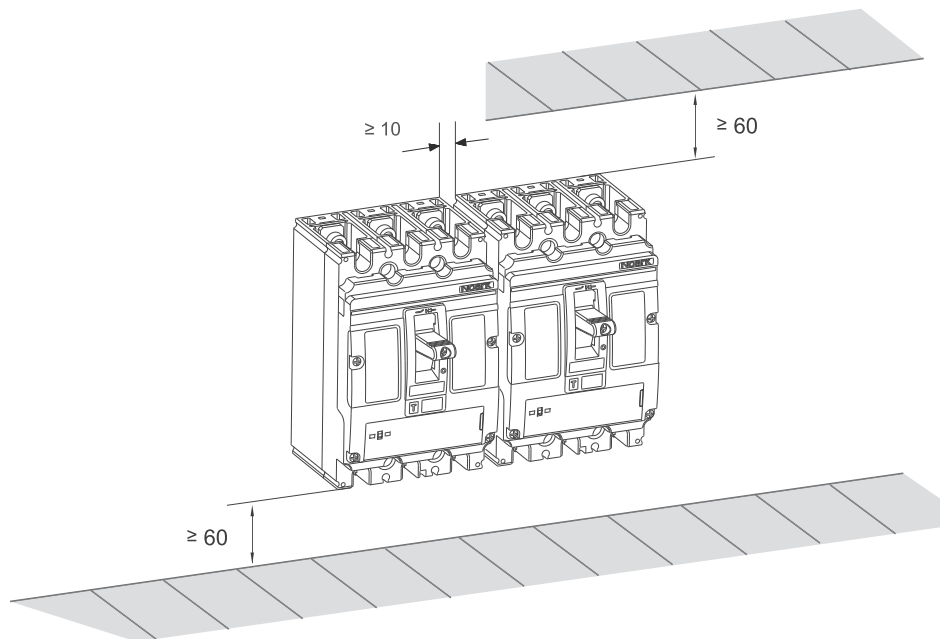

Ordering information p. 60



# Technical Data Ex9M Accessories

## Accessories for Moulded Case Circuit Breakers Ex9M

### Auxiliary and signal contact units AX21, AL21

#### General parameters

Contact units for auxiliary and signal contact functions are suitable for all MCCB frame sizes

Auxiliary contacts synchronous with main contacts of the circuit breaker

Signal contacts active on electrical tripping of the circuit breaker (tripping signal contacts)

With connection wires

#### Electrical parameters

	AX21	AL21
Contacts	1 changeover (CO)	1 changeover (CO)
Contact function	auxiliary	signal
Tested according to	IEC/EN 60947-1, IEC/EN 60947-5-1	
Rated op. voltage U	240/415 V AC, 110/220 V DC	
Rated frequency	50/60 Hz	
Rated op. current I <sub>e</sub> AC	5 A (240 V), 2 A (415 V)	
Rated op. current I <sub>e</sub> DC	1 A (110 V), 0.25 A (220 V)	
Rated thermal current I <sub>th</sub>	5 A	
Rated op. current I <sub>e</sub> , ut. cat. AC-15	5 A (240 V), 2 A (415 V)	
Rated op. current I <sub>e</sub> , ut. cat. DC-13	1 A (110 V), 0.25 A (220 V)	
Rated insulation voltage U <sub>i</sub>	500 V	

#### Mechanical parameters

	AX21	AL21
Suitable for	M1, M2, M3, M4, M5	M1, M2, M3, M4, M5
Connection	equipped with connection wires	

#### Wiring diagrams

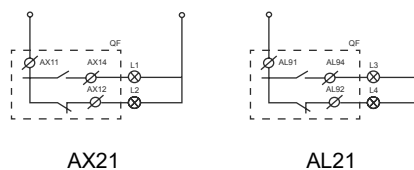

# Technical Data Ex9M Accessories

## Accessories for Moulded Case Circuit Breakers Ex9M

### Early-make auxiliary contacts EC 2i

#### General parameters

Early-make auxiliary contacts

Contact unit EC 21 is installed in the special place in the MCCB (M1, M2 frame size), unit EC 23 as two connected contact units. One in special place and second in AL place (limit use of AL in M3, M4, M5)

Does not limit using of voltage releases and motor operator

Equipped with connection wires

Compatible with MCCB devices produced from 3/2014 only!

Please, note the requirement for early-make contact function in the order of MCCB!

#### Electrical parameters

	EC 21	EC 23
Contacts	1 NO	1 NO
Contact function	early-make auxiliary	
Tested according to	IEC/EN 60947-1, IEC/EN 60947-5-1	
Rated op. voltage U	240/415 V AC, 110/220 V DC	
Rated frequency	50/60 Hz	
Rated op. current I <sub>e</sub> AC	5 A (240 V), 2 A (415 V)	
Rated op. current I <sub>e</sub> DC	1 A (110 V), 0.25 A (220 V)	
Rated thermal current I <sub>th</sub>	5 A	
Rated op. current I <sub>e</sub> , ut. cat. AC-15	5 A (240 V), 2 A (415 V)	
Rated op. current I <sub>e</sub> , ut. cat. DC-13	1 A (110 V), 0.25 A (220 V)	
Rated insulation voltage U <sub>i</sub>	500 V	
Early make function	M1, ON -> OFF: 10 ms M1, OFF -> ON: 15 ms M2, ON -> OFF: 16 ms M2, OFF -> ON: 18 ms	M3, ON -> OFF: 68 ms M3, OFF -> ON: 75 ms M4/M5, ON -> OFF: 82 ms M4/M5, OFF -> ON: 90 ms

#### Mechanical parameters

	EC 21	EC 23
Suitable for	M1, M2	M3, M4, M5
Connection	equipped with connection wires	

# Technical Data Ex9M Accessories

## Accessories for Moulded Case Circuit Breakers Ex9M

### Early-make auxiliary contacts EC 2i

#### Wiring diagrams

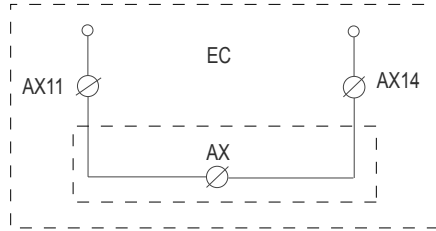

EC 21

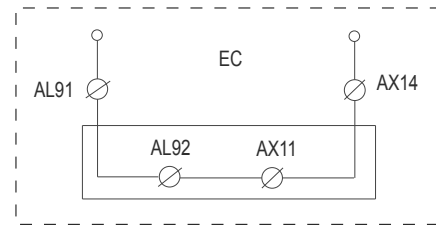

EC 23

#### Mounting position

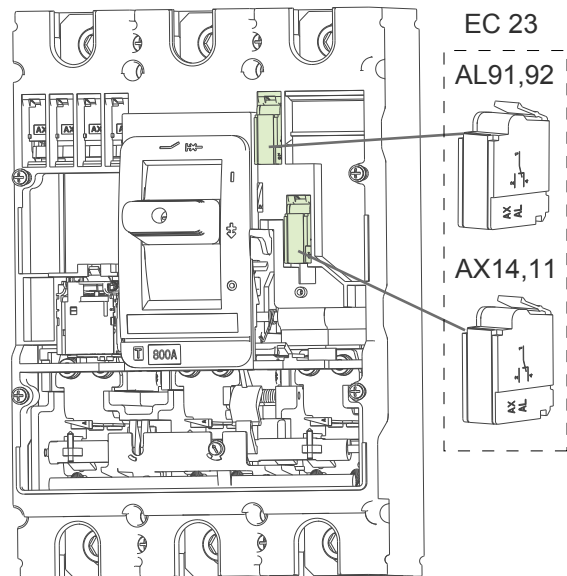
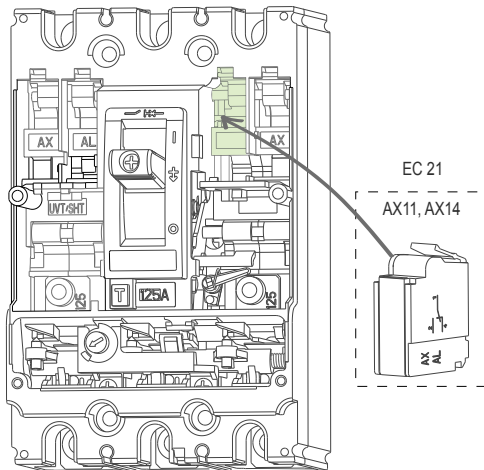

Matching order of the contact units and respective chambers has to be kept!

# Technical Data Ex9M Accessories

## Accessories for Moulded Case Circuit Breakers Ex9M

### Shunt trip releases SHT2*i*

#### General parameters

It is possible to use one unit of shunt trip release SHT2*i* or one unit of undervoltage release UVT2*i*

Can be used for remote switch off

SHT21 for MCCBs of frame size M1

SHT22 for MCCBs of frame sizes M2 and M3

SHT24 for MCCBs of frame sizes M4 and M5

With connection wires

#### Electrical parameters

	SHT21	SHT22	SHT24
Tested according to	IEC/EN 60947-1, IEC/EN 60947-5-1		
Rated operating voltage U (according to type)	48 V AC 110 V AC 220 — 240 V AC 380 — 415 V AC 24 V DC 48 V DC 110 V DC 220 V DC	48 V AC 110 V AC 220 — 240 V AC 380 — 415 V AC 24 V DC 48 V DC 110 V DC 220 V DC	110 V AC 220 — 240 V AC 380 — 415 V AC 110 — 120 V DC 220 V DC 24 V DC 48 V DC
Rated frequency	50/60 Hz DC		
Rated insulation voltage U	500 V		
Tripping time	< 20 ms	< 20 ms	< 30 ms

#### Mechanical parameters

	SHT21	SHT22	SHT24
Suitable for	M1	M2, M3	M4, M5
Connection	equipped with connection wires		

#### Wiring diagrams

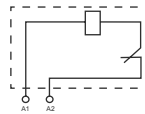

SHT2*i*

# Technical Data Ex9M Accessories

## Accessories for Moulded Case Circuit Breakers Ex9M

### Undervoltage releases UVT2i

#### General parameters

It is possible to use one unit of shunt trip release SHT2i or one unit of undervoltage release UVT2i

To switch connected breaker off in case of voltage drop

UVT21 for MCCBs of frame size M1

UVT22 for MCCBs of frame size M2 and M3

UVT24 for MCCBs of frame size M4 and M5

With connection wires

#### Electrical parameters

	UVT21	UVT22	UVT24
Tested according to	IEC/EN 60947-1, IEC/EN 60947-5-1		
Rated operating voltage $U_n$	220 — 240 V AC 380 — 415 V AC	220 — 240 V AC 380 — 415 V AC	110 V AC 220 — 240 V AC 380 — 415 V AC 110 — 120 V DC 220 V DC 24 V DC 48 V DC
Rated frequency $f$	50/60 Hz DC		
Rated insulation voltage $U_i$	500 V		
Tripping time	< 20 ms	< 20 ms	< 20 ms
Making treshold	85 % $U_n$	85 % $U_n$	85 % $U_n$
Tripping treshold	35 % $U_n$	35 % $U_n$	35 % $U_n$

#### Mechanical parameters

	UVT21	UVT22	UVT24
Suitable for	M1	M2, M3	M4, M5
Connection	equipped with connection wires		

#### Wiring diagrams

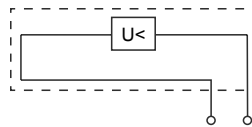

UVT2i

# Technical Data Ex9M Accessories

## Accessories for Moulded Case Circuit Breakers Ex9M

### Direct rotary handles RHD2i

#### General parameters

Rotary handle for direct mounting onto breaker

Scope of delivery: mechanism block, rotary handle

Can be locked in ON and OFF position with up to three padlocks (not in the scope of delivery)

#### Electrical parameters

	RHD21	RHD22	RHD23	RHD24
Tested according to	IEC/EN 60947-3			
Degree of protection	IP40			

#### Mechanical parameters

	RHD21	RHD22	RHD23	RHD24
Suitable for	M1	M2	M3	M4, M5
Mechanical shock resistance	IK07			
Indication	connected breaker status ON-OFF-TRIP			
Mounting	directly onto breaker			
Toggle colour	grey			

#### Dimensions

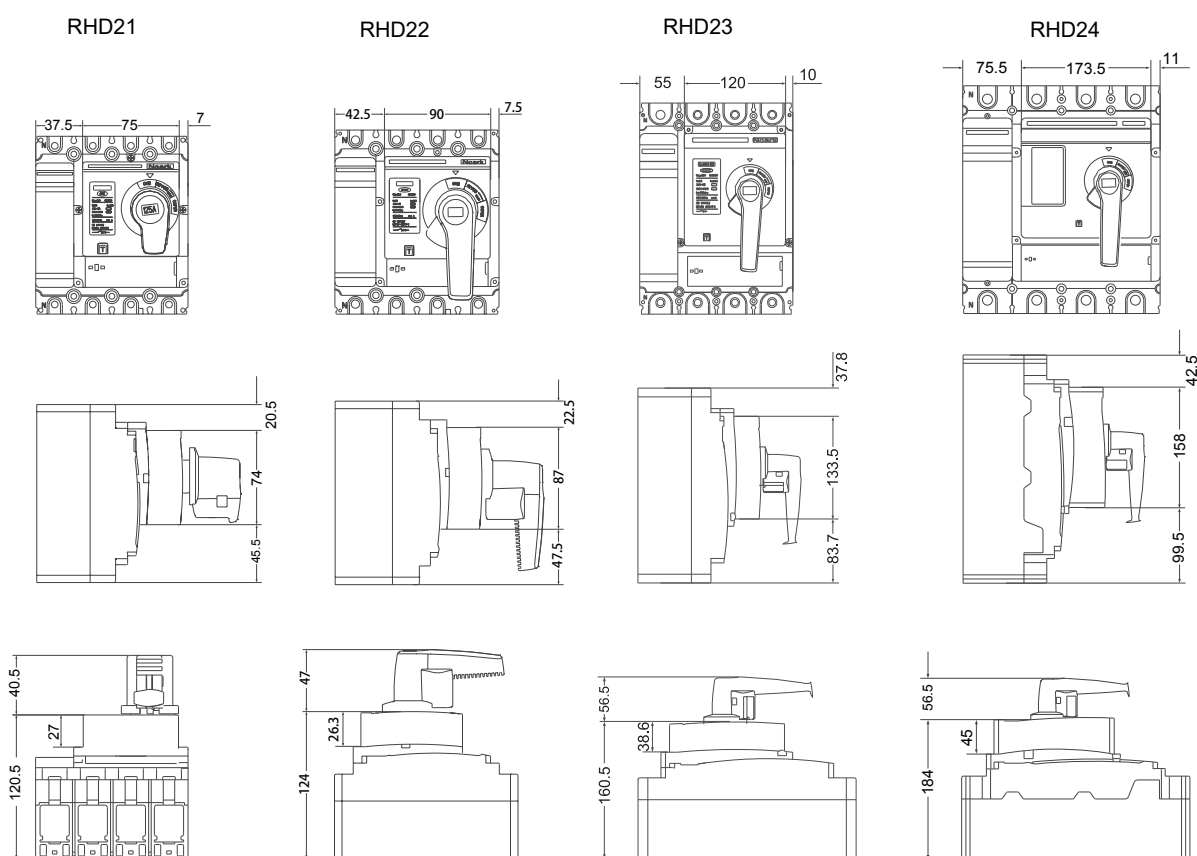

Ordering information p. 64

# Technical Data Ex9M Accessories

## Accessories for Moulded Case Circuit Breakers Ex9M

### Extended rotary handles ERH2i

#### General parameters

Rotary handle with extension shaft

Scope of delivery: mechanism block, extension shaft, rotary handle

Can be locked in ON and OFF position with up to three padlocks (not in the scope of delivery)

Extension shaft can be shortened

Possibility of longer extension shaft 500 mm (only the shaft as separated item)

#### Electrical parameters

	ERH21	ERH22	ERH23	ERH24
Tested according to	IEC/EN 60947-3			
Degree of protection	IP54			

#### Mechanical parameters

	ERH21	ERH22	ERH23	ERH24
Suitable for	M1	M2	M3	M4, M5
Length of the extension shaft	300 mm	300 mm	300 mm	300 mm
Mechanical shock resistance	IK08			
Indication	connected breaker status ON-OFF-TRIP			
Mounting	directly onto breaker			
Toggle colour	grey			

#### Dimensions

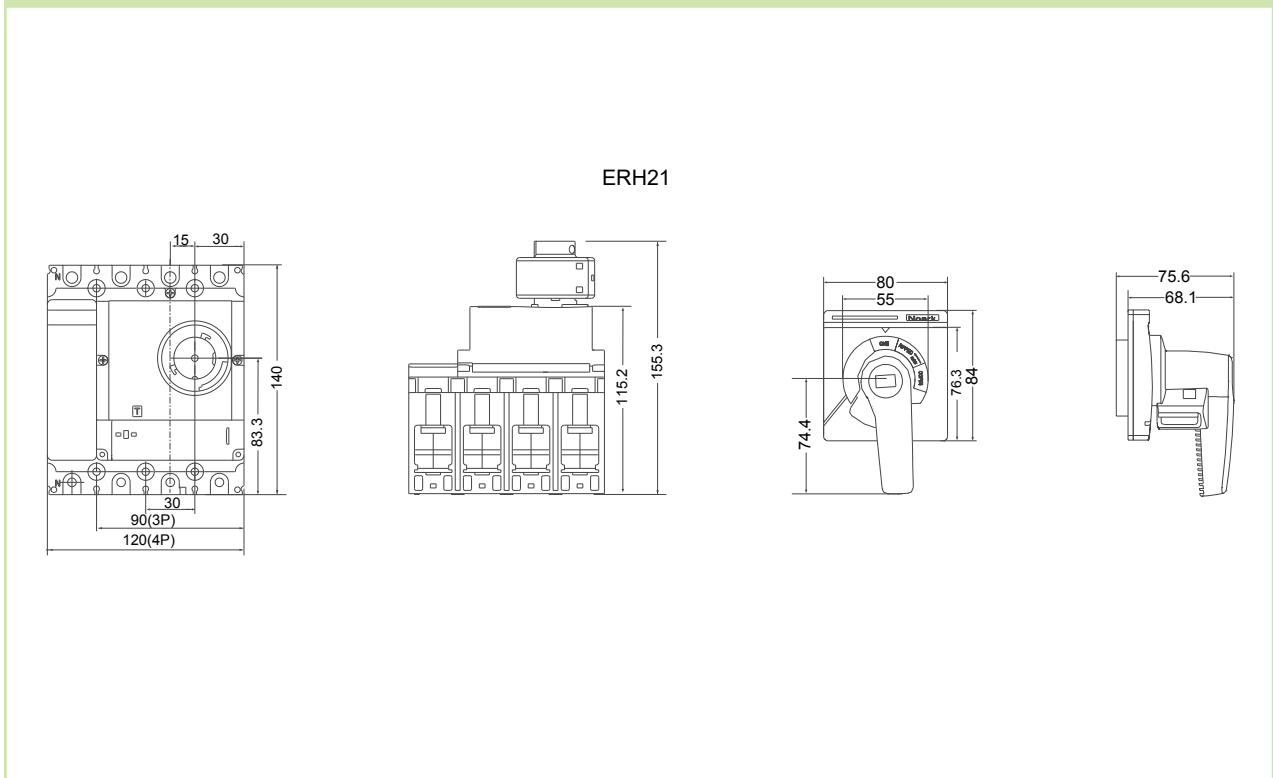

# Technical Data Ex9M Accessories

## Accessories for Moulded Case Circuit Breakers Ex9M

### Extended rotary handles ERH2i

#### Dimensions

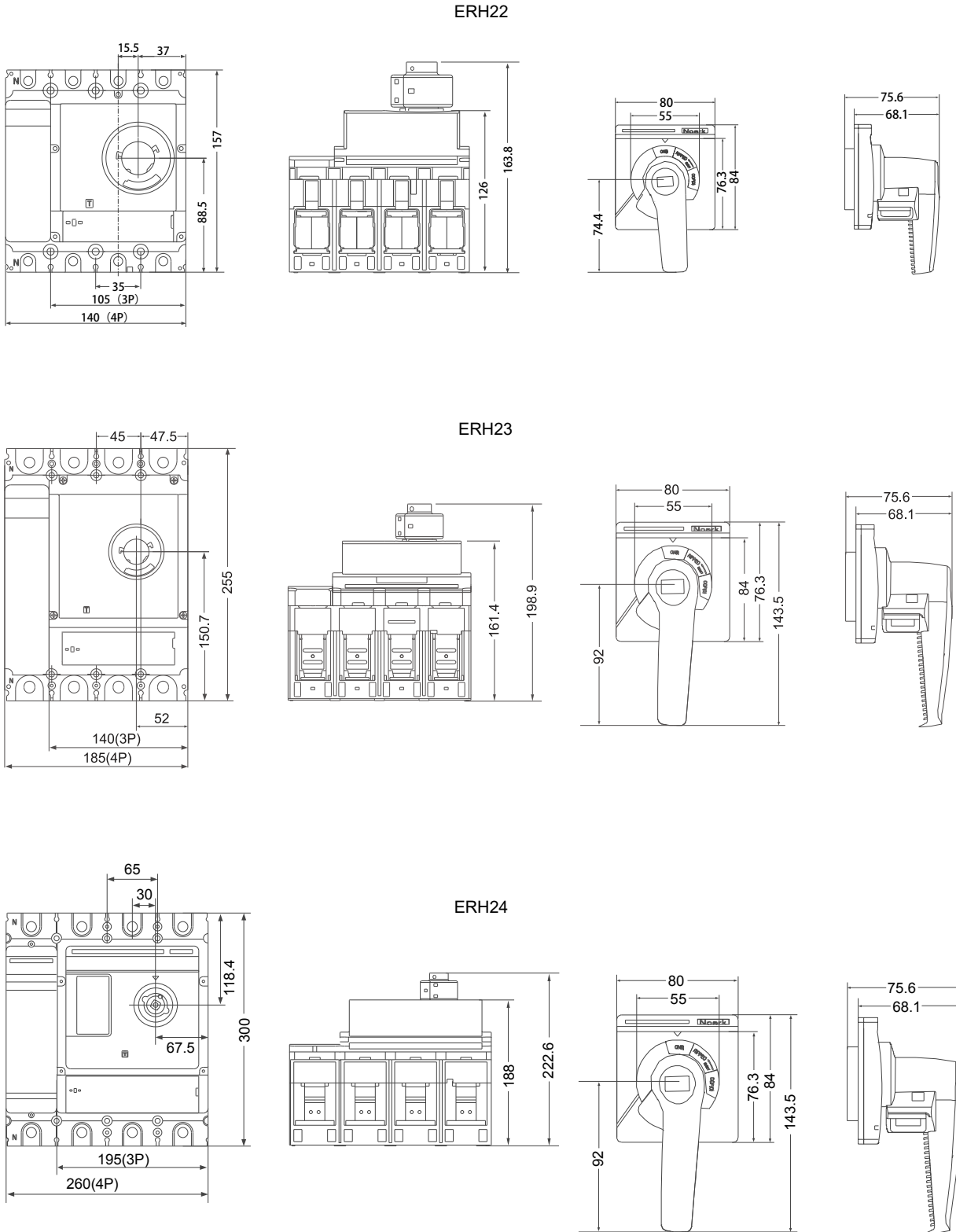

Ordering information p. 64



# Technical Data Ex9M Accessories

## Accessories for Moulded Case Circuit Breakers Ex9M

### Remote motor operators MOD2i

#### General parameters

Motor drives for electrical and remote control of MCCBs

#### Electrical parameters

	MOD21	MOD22	MOD23	MOD24
Tested according to	IEC/EN 60947-1, IEC/EN 60947-5-1			
Rated operating voltage $U_s$ (according to type)	230 V AC 110 V AC 220 V DC 110 V DC 24 V DC			
Rated frequency	50/60 Hz DC			
Power consumption	150 VA	150 VA	300 VA	300 VA
Total time to switch ON	75 ms	75 ms	1000 ms	1000 ms
Total time to switch OFF	500 ms	500 ms	1000 ms	1000 ms
Min. pulse duration for ON	300 ms	300 ms	300 ms	300 ms
Min. pulse duration for OFF	300 ms	300 ms	300 ms	300 ms
Max. pulse duration	limited by internal contact switch			

#### Mechanical parameters

	MOD21	MOD22	MOD23	MOD24
Suitable for	M1	M2	M3	M4, M5
Terminals	lift			
Terminal capacity	0.2 — 1.5 mm <sup>2</sup>			
Mechanical service life	10 000 operation cycles		8 000 operation cycles	
Maximum frequency of switch. cycles	120 operating cycles per hour			

#### Wiring diagram

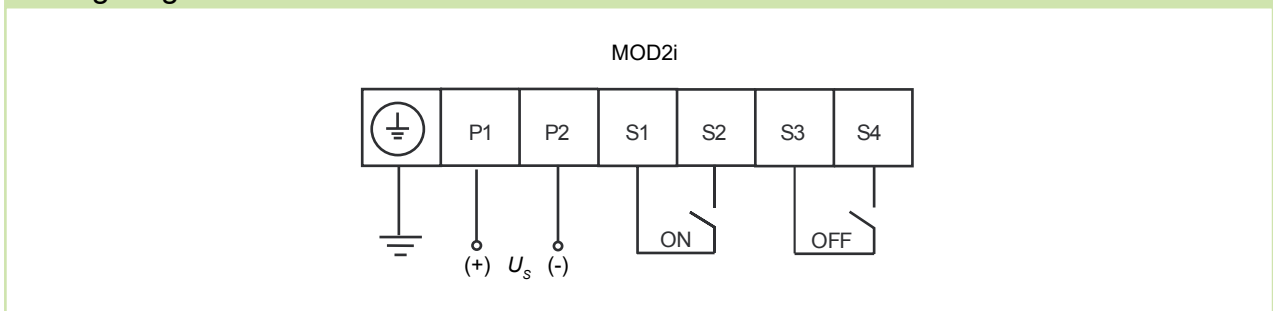

# Technical Data Ex9M Accessories

## Accessories for Moulded Case Circuit Breakers Ex9M

### Remote motor operators MOD2*i*

#### Dimensions

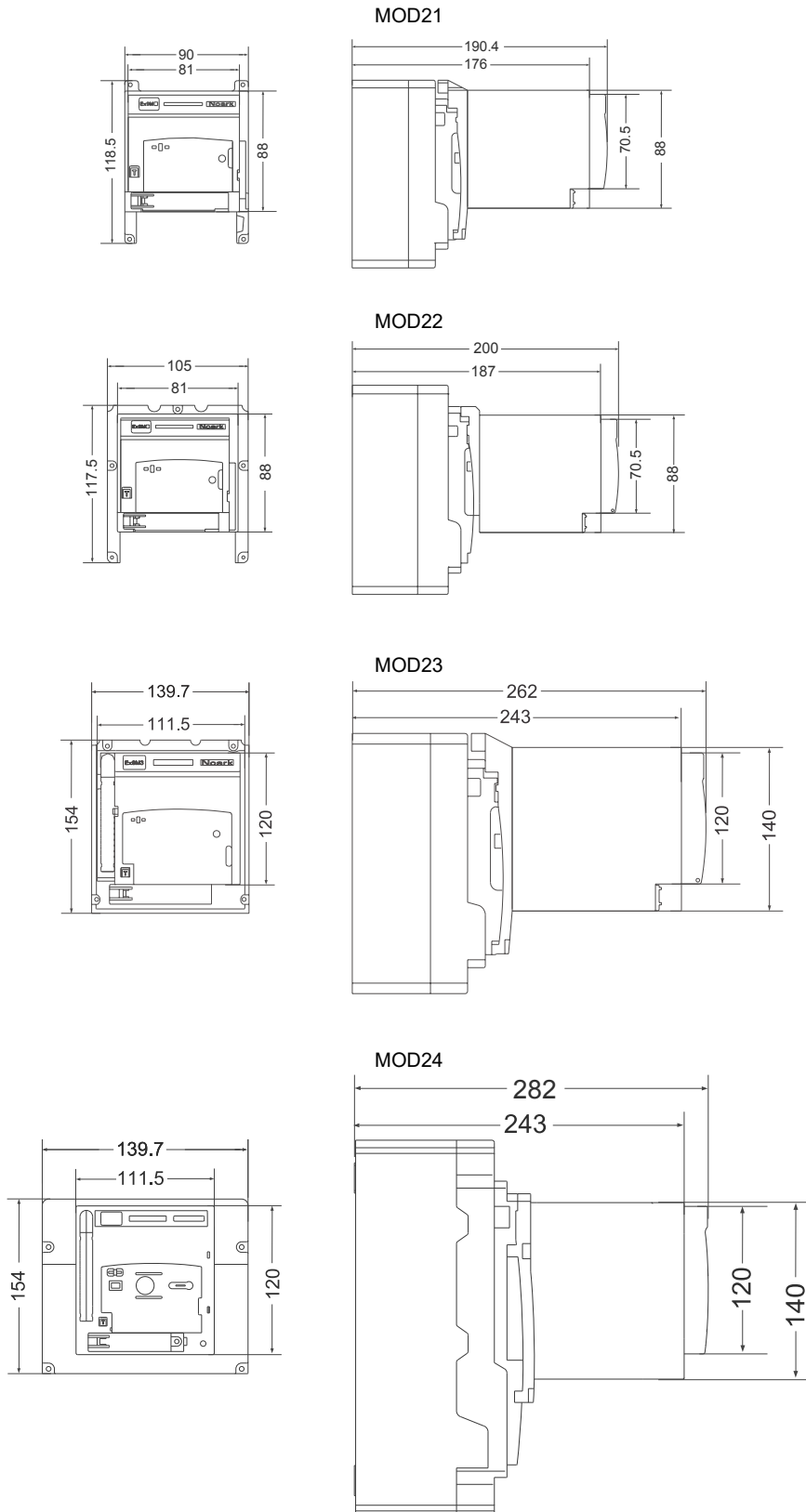

Ordering information p. 63

# Technical Data Ex9M Accessories

## Accessories for Moulded Case Circuit Breakers Ex9M

### Connection terminals MC2i

#### General parameters

Box and tunnel connection terminals for Ex9M MCCBs and MCCB based switch disconnectors

Versions suitable for all frame sizes

Screws in the scope of delivery

#### Mechanical parameters - box terminals

	MC21	MC22	MC23	MC23 UL
Suitable for	M1	M2	M3	M3
Terminal type	box			
Terminal capacity	4 — 95 mm <sup>2</sup>	10 — 120 mm <sup>2</sup>	120 — 240 mm <sup>2</sup>	120 — 240 mm <sup>2</sup>
Fastening torque of terminals	8 Nm	25 Nm	35 Nm	35 Nm

#### Drawings - box terminals



MC21(22)



MC23

#### Mechanical parameters - tunnel terminals

	MC21 W	MC22 W	MC22 W2	MC22 W6	MC23 W2	MC23 W4	MC24 W2
Suitable for	M1	M2	M2	M2	M3	M3	M4, M5
Terminal type	tunnel						
Terminal capacity	1x 16 - 95 mm <sup>2</sup>	1x 35 - 240 mm <sup>2</sup>	2x 35 - 120 mm <sup>2</sup>	6x 10 - 35 mm <sup>2</sup>	2x 120 - 240 mm <sup>2</sup>	4x 35 - 95 mm <sup>2</sup>	2x 240 mm <sup>2</sup>
Fastening torque of terminals (to MCCB)	10 - 15 Nm	15 Nm	15 Nm	15 Nm	35 Nm	35 Nm	35 Nm
Fastening torque of terminals (wires)	10 Nm	30 Nm	30 Nm	10 Nm	35 Nm	30 Nm	35 Nm

#### Drawings - tunnel terminals

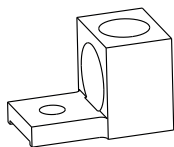

MC21 W

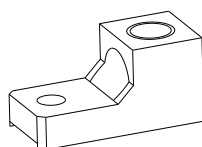

MC22 W

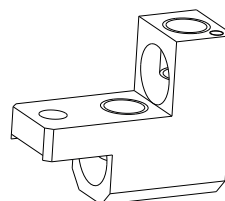

MC22 W2

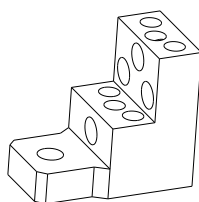

MC22 W6

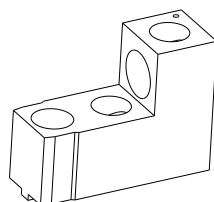

MC23 W2

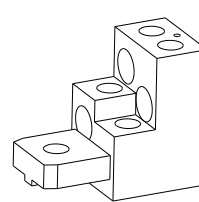

MC23 W4

# Technical Data Ex9M Accessories

## Accessories for Moulded Case Circuit Breakers Ex9M

### DIN-rail adaptors DRA2i

#### General parameters

Adaptors for mounting of MCCBs and MCCB Switch Disconnectors onto 35 mm device DIN-rail

Suitable for M1 and M2 frame sizes, 3P and 4P versions

#### Mechanical parameters

	DRA21	DRA22
Suitable for	M1	M2
Mounting	easy mounting onto 35 mm device rail (DIN)	

#### Drawings and dimensions

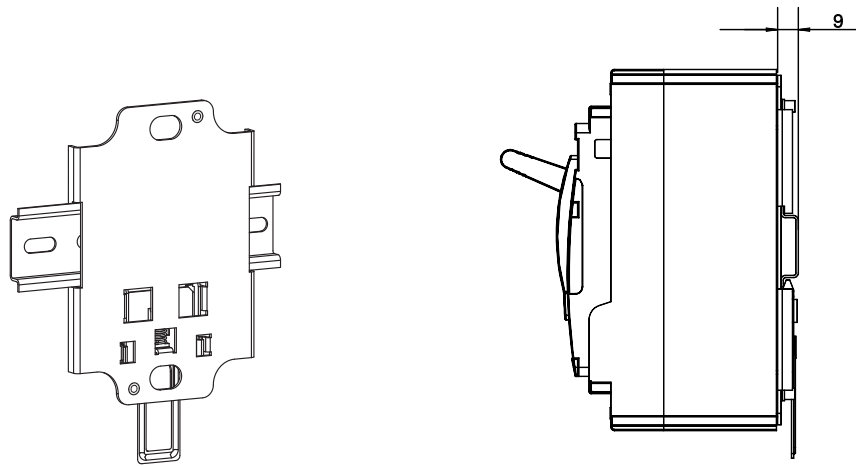

# Technical Data Ex9M Accessories

## Accessories for Moulded Case Circuit Breakers Ex9M

### Mounting depth spacers WG

#### General parameters

Set of mounting depth spacers for compensation of differences in height between frame sizes

Suitable for all variants of MCCBs and MCCB Switch Disconnectors

Variants with height 10 and 13 mm

#### Mechanical parameters

	WG 10	WG 13
Suitable for height compensation	M1 -> M2	M2 -> M3 M3 -> M4/M5
Height	10 mm	13 mm

#### Mounting

WG \ Ex9M	9M1/9M2	9M1/9M3	9M1/9M4	9M2/9M3	9M2/9M4	9M3/9M4
WG10	4X	4X	4X			
WG13		8X	12X	8X	12X	4X

# Technical Data Ex9M6 Accessories

## Accessories for electronic Moulded Case Circuit Breakers Ex9M6

### Auxiliary and signal contact units AX21, AL21

#### General parameters

Contact units for auxiliary and signal contact functions are suitable for all MCCB frame sizes
Auxiliary contacts synchronous with main contacts of the circuit breaker
Signal contacts active on electrical tripping of the circuit breaker (tripping signal contacts)
With connection wires

#### Electrical parameters

	AX21	AL21
Contacts	1 changeover (CO)	1 changeover (CO)
Contact function	auxiliary	signal
Tested according to	IEC/EN 60947-1, IEC/EN 60947-5-1	
Rated op. voltage U	240/415 V AC, 110/220 V DC	
Rated frequency	50/60 Hz	
Rated op. current I <sub>o</sub> AC	5 A (240 V), 2 A (415 V)	
Rated op. current I <sub>o</sub> DC	1 A (110 V), 0.25 A (220 V)	
Rated thermal current I <sub>th</sub>	5 A	
Rated op. current I <sub>o</sub> , ut. cat. AC-15	5 A (240 V), 2 A (415 V)	
Rated op. current I <sub>o</sub> , ut. cat. DC-13	1 A (110 V), 0.25 A (220 V)	
Rated insulation voltage U <sub>i</sub>	500 V	

#### Mechanical parameters

	AX21	AL21
Suitable for MCCBs size	M1, M2, M3, M4, M5, M6	M1, M2, M3, M4, M5, M6
Connection	equipped with connection wires	

#### Wiring diagrams

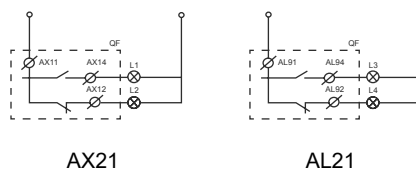

# Technical Data Ex9M6 Accessories

## Accessories for electronic Moulded Case Circuit Breakers Ex9M6

### Shunt trip releases SHT26

#### General parameters

Remotely opens the breaker after supplying of control impulse

Operating voltage range 85-110 % of nominal value  $U_e$ . Maximum allowed control command length 2 s (can be blocked e.g. by means of NO auxiliary contact)

#### Electrical parameters

Operating voltage $U_e$	48 V AC 110 V AC 220-240 V AC 380-415 V AC 24 V DC 48 V DC 110 V DC 220 V DC
Operating threshold	70 - 110% $U_e$
Pick-up power time 100ms AC DC	200 VA 200 W
Power consumption AC DC	5 VA 5 W
Minimum duration of control impuls	0.2 s
Max. allowed duration of control impuls	2 s
Circuit breaker opening time	< 30 ms
Breaking time	50 ± 10 ms
Insulation voltage	415 V
Peak current	6 x $I_n$

#### Connection diagram for long control signals

In case external control circuit cannot assure not-exceeding of max. impuls duration, AX contact of NO configuration can be used for limiting (direct connection with SHT 230 or 400 V AC, signal to advanced control system in case of use of SHT for DC control voltages due to maximum allowed current of AX).

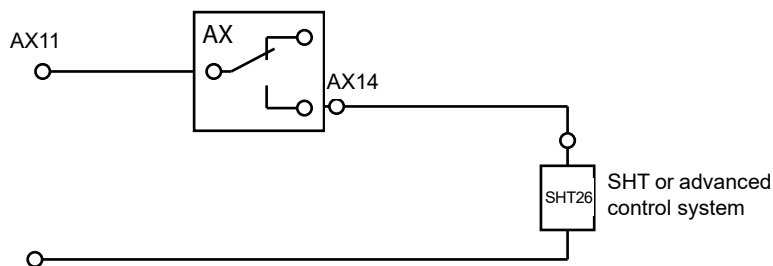

# Technical Data Ex9M6 Accessories

## Accessories for electronic Moulded Case Circuit Breakers Ex9M6

### Shunt trip releases UVT26

#### General parameters

Opens the breaker when the voltage drops or power off to prevent the load from damage caused by undervoltage
The control power supply of UVT could be from the primary side of circuit breaker or from independent supply
The undervoltage release instantaneously opens the circuit breaker when its supply voltage drops to a value between 35 % and 70 % of its rated voltage
If the voltage is less than 35 % of supply voltage $U_e$ , it is impossible to close the circuit breaker
Circuit breaker can be closed when the supply voltage of the release is 85 % - 110 % of supply voltage $U_e$

#### Electrical parameters

Operating voltage $U_e$	220 - 240 V AC 380 - 415 V AC
Operating threshold not close actuation closing	< 35 % $U_e$ 35 - 70 % $U_e$ 85 - 110 % $U_e$
Pick-up power	200 VA
Power consumption	50 VA
Accuracy	$\pm 20$ %
Insulation voltage	415 V

#### Mechanical parameters

	<b>UVT26</b>
Suitable for	Ex9M6
Connection	equipped with connection wires

#### Wiring diagrams

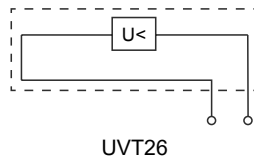



# Technical Data Ex9M6 Accessories

## Accessories for electronic Moulded Case Circuit Breakers Ex9M6

### Extended rotary handles ERH26

#### General parameters

Rotary handle with extension shaft

Scope of delivery: mechanism block, extension shaft, rotary handle

Can be locked in ON and OFF position with up to three padlocks (not in the scope of delivery)

Extension shaft can be shortened

#### Mechanical parameters

	<b>ERH26</b>
Suitable for	Ex9M6
Length of the extension shaft	150 mm min
Indication	connected breaker status ON-OFF-TRIP
Degree of protection	IP30
Mounting	directly onto breaker
Toggle colour	black

#### Dimensions

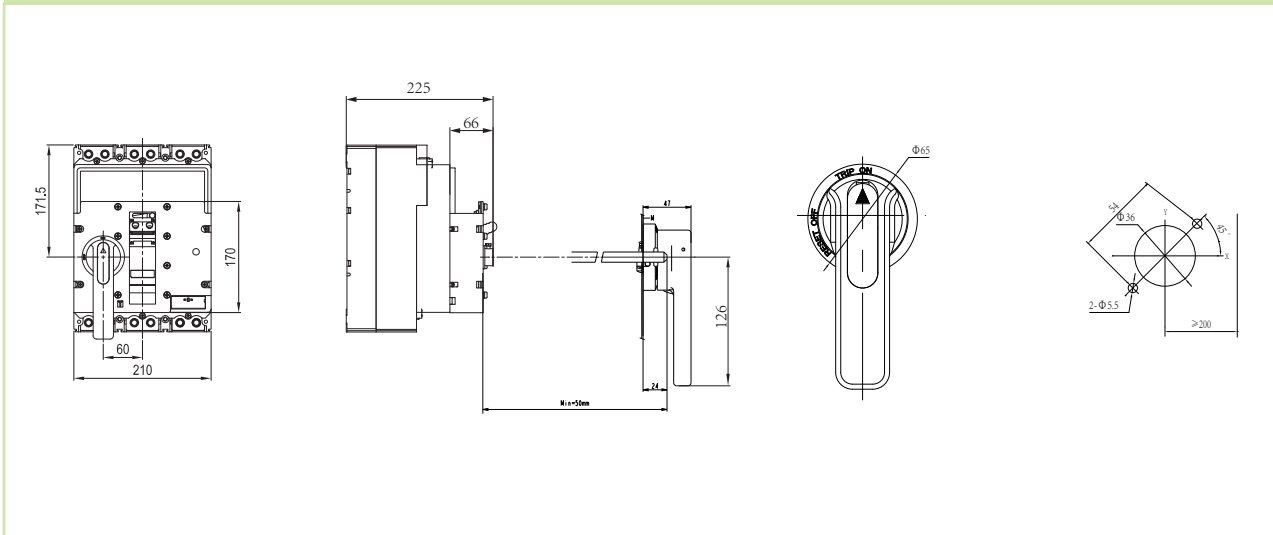

# Technical Data Ex9M6 Accessories

## Accessories for electronic Moulded Case Circuit Breakers Ex9M6

### Extended handle LHD26

#### General parameters

Extended handle for easier operation of the device

Scope of delivery: mechanism locker, extended handle

#### Mechanical parameters

	<b>LHD26</b>
Suitable for	Ex9M6
Length of the extended toggle	172 mm min
Indication	connected breaker status ON-OFF-TRIP
Mounting	directly onto breaker
Toggle colour	grey

#### Dimensions

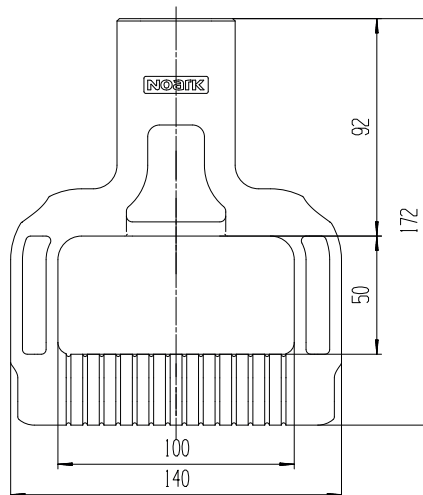

# Technical Data Ex9MV2S Accessories

## Accessories for Moulded Case Circuit Breakers Ex9MV2S

### Auxiliary and signal contact units AX22V, AL22V and combinations

#### General parameters

Contact units for auxiliary and signal contact functions are suitable for all MCCB frame sizes

Auxiliary contacts synchronous with main contacts of the circuit breaker

Signal contacts active on electrical tripping of the circuit breaker (tripping signal contacts)

With connection wires

#### Electrical parameters

	AX22V	2AX22V	AL22V	AX+AL22V	AX22VR	2AX22VR
Contacts	1 changeover (CO)	2 changeover (CO)	1 changeover (CO)	2 changeover (CO)	1 changeover (CO)	2 changeover (CO)
Contact function	auxiliary left	auxiliary left	signal left	auxiliary + signal left	auxiliary right	auxiliary right
Maximum op. voltage U	AC400V/DC220V					
Rated frequency	50/60 Hz					
Rated op. current I <sub>e</sub> AC	1.5A					
Rated op. current I <sub>e</sub> DC	0.15A					
Rated thermal current I <sub>th</sub>	3 A					
Rated op. current I <sub>e</sub> , ut. cat. AC-15	5 A (240 V), 2 A (415 V)					
Rated op. current I <sub>e</sub> , ut. cat. DC-13	1 A (110 V), 0.25 A (220 V)					
Rated insulation voltage U <sub>i</sub>	400 V					

#### Mechanical parameters

	AX22V	2AX22V	AL22V	AX+AL22V	AX22VR	2AX22VR
Suitable for	Ex9MV2S					
Connection	Equipped with connection wires					

#### Wiring diagrams

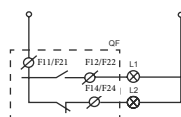

2AX22V  
2AX22VR

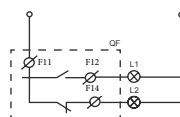

AX22V  
AX22VR  
AX+AL22V

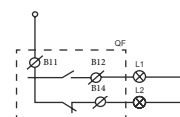

AL22V  
AX+AL22V

# Technical Data Ex9MV2S Accessories

## Accessories for Moulded Case Circuit Breakers Ex9MV2S

### Shunt trip releases SHT22VR

#### General parameters

It is possible to use one unit of shunt trip release SHT22VR on the right side of the MCCB

Can be used for remote switch off

With connection wires

#### Electrical parameters

	<b>SHT22VR</b>
Rated operating voltage $U_e$ (according to type)	24 V DC
	230 V AC
	400 V AC
Rated frequency	50/60 Hz
Rated insulation voltage $U_i$	400 V
Tripping time	$\leq 500$ ms

#### Mechanical parameters

	<b>SHT22VR</b>
Suitable for	Ex9MV2S
Connection	Equipped with connection wires

#### Wiring diagrams

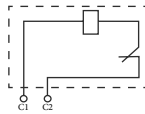

SHT22VR

# Technical Data Ex9MV2S Accessories

## Accessories for Moulded Case Circuit Breakers Ex9MV2S

### Extended rotary handles ERH-1

#### General parameters

Rotary handle with extension shaft

Scope of delivery: mechanism block, extension shaft, rotary handle

Can be locked in ON and OFF position with padlocks (not in the scope of delivery)

Extension shaft can be shortened

#### Electrical parameters

	<b>ERH-1</b>
Degree of protection	IP20

#### Mechanical parameters

	<b>ERH-1</b>
Suitable for	Ex9MV2S
Length of the extension shaft	300 mm (min 50 mm if shorted)
Indication	Connected breaker status ON-OFF-TRIP
Mounting	Directly onto breaker
Toggle colour	Black

#### Dimensions

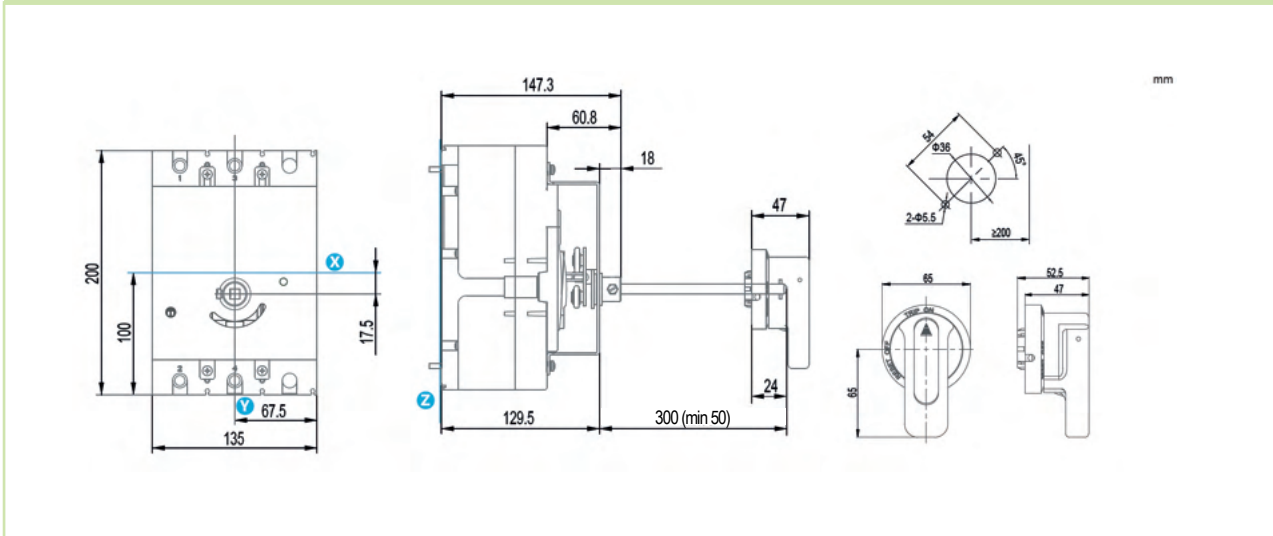

# Index

Type	Ordering data	Technical data	Type	Ordering data	Technical data
AL21	62	151	WG	66	163
AX21	62	151	XF26		99
AX22	72	169			
DRA2	66	162			
EC 2	62	152			
ERH-1	72	171			
ERH2	64	157			
ERH26	69	167			
Ex9M1	8	75			
Ex9M1SD AC	36	100			
Ex9M1SD DC	60	136			
Ex9M2	10	78			
Ex9M2SD AC	36	103			
Ex9M2SD DC	60	139			
Ex9M3	12	81			
Ex9M3SD AC	36	106			
Ex9M3SD DC	60	142			
Ex9M4	14	84			
Ex9M4SD AC	36	109			
Ex9M4SD DC	60	145			
Ex9M5	16	87			
Ex9M5SD AC	36	112			
Ex9M5SD DC	60	148			
Ex9M6	22	90			
Ex9M6 MOD	26	94			
Ex9M6SD AC	40	115			
Ex9MD1	44	118			
Ex9MD2	46	121			
Ex9MD3	48	124			
Ex9MD4	50	127			
Ex9MD5	52	130			
Ex9MV2S	56	133			
JP26	69				
LHD26	69	168			
MC2	65	161			
MOD2	63	159			
MOD		98			
PB2	64				
RHD2	64	156			
SHT2	62	154			
SHT22	72	170			
SHT26	68	165			
TCE2	66				
TCV2	65				
UVT2	63	155			
UVT26	68	166			

# NOARK

## 10 REASONS FOR NOARK

- 1 RELIABILITY
- 2 FIVE YEAR WARRANTY
- 3 SIMPLE INSTALLATION
- 4 FUNCTIONAL DESIGN
- 5 MANUFACTURING QUALITY
- 6 UNBEATABLE SUPPORT
- 7 INDIVIDUAL APPROACH
- 8 WIDE DISTRIBUTION NETWORK
- 9 FLEXIBILITY
- 10 TRUSTED BY CUSTOMERS





**NOARK Electric Europe s.r.o.**

Sezemická 2757/2, 193 00 Prague 9, Czech Republic

Phone: +420 226 203 120

E-mail: [Europe@noark-electric.com](mailto:Europe@noark-electric.com)

[www.noark-electric.eu](http://www.noark-electric.eu)

# NOARK

